

TECHNICAL MANUAL
OPERATOR, UNIT
DIRECT SUPPORT, AND
GENERAL SUPPORT
MAINTENANCE INSTRUCTIONS
PROPELLING UNIT, OUTBOARD
NSN 2010-01-251-2227

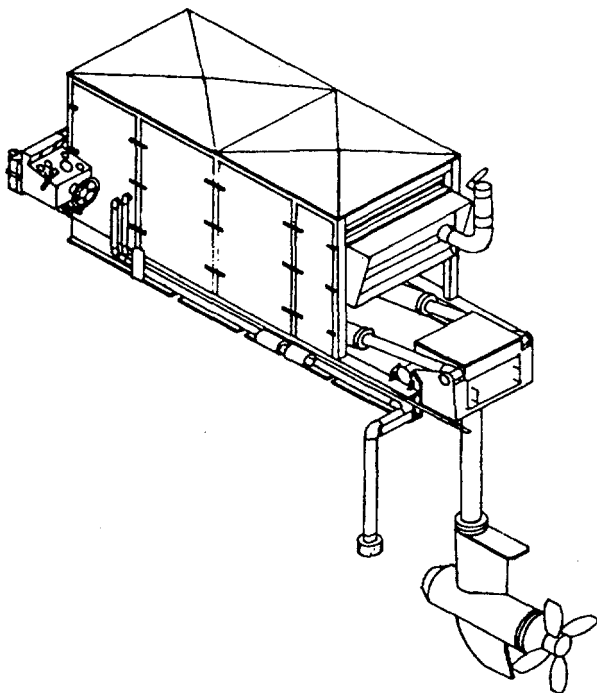

INTRODUCTION 1-1

OPERATING INSTRUCTIONS 2-1

OPERATOR MAINTENANCE 3-1

UNIT MAINTENANCE 4-1

**DIRECT SUPPORT
MAINTENANCE 5-1**

**GENERAL SUPPORT
MAINTENANCE 6-1**

APPENDICES

Approved for public release. Distribution is unlimited.

HEADQUARTERS, DEPARTMENT OF THE ARMY

5 APRIL 1991

WARNING

MODIFICATION HAZARDS

Unauthorized modifications, alterations or installations of or to this equipment are prohibited and are in violation of Army Regulation (AR) 750-10. Any such unauthorized modifications, alterations or installations could result in injury, death, or damage to the equipment.

CLEANING SOLVENTS

Dry cleaning solvent (Federal Specification PD-680), acetone, and methyl ethyl ketone (MEK) are toxic and highly flammable. Use only in a well ventilated area. Avoid prolonged breathing of fumes. Always wear eye protection and protective clothing when using solvents.

COOLING SYSTEM

Use caution when removing the expansion tank cap while the engine is still hot.

To prevent burns and to prevent damage to the engine, do not add coolant to an overheated engine. Allow the engine to cool first.

MOVING MACHINERY HAZARDS

Place a warning tag on the control panel indicating the unit is out of service before inspecting.

HIGH TEMPERATURES

Use caution when working around the exhaust system. Can be hot to the touch.

**For Artificial Respiration,
refer to FM 21-11**

a/(b-blank)

TECHNICAL MANUAL

No. 5-2010-205-14

HEADQUARTERS
DEPARTMENT OF THE ARMY
WASHINGTON, D.C 5 APRIL 1991

Operator, Unit Direct Support
and General Support Maintenance Manual

Propelling Unit, Outboard Diesel, 165 hp
NSN: 2010-01-251-2227

REPORTING ERRORS AND RECOMMENDING IMPROVEMENTS

You can help improve this manual. If you find any mistake or if you know of a way to improve the procedures, please let us know. Mail your letter DA FORM 2028 (Recommended Changes to Publications and Blank Forms) or DA Form 2028-2 located in the back of this manual directly to: Commander, U.S. Army Troop Support Command, ATTN: AMSTR-MMTS, 4300 Goodfellow Boulevard, St. Louis, MO 63120-1798. A reply will be furnished directly to you.

Approved for public release; distribution is unlimited.

TABLE OF CONTENTS

		<u>PAGE</u>
HOW TO USE THIS MANUAL.....		iii
CHAPTER 1	INTRODUCTION	
Section I	General Information.....	1-1
Section II	Equipment Description and Data.....	1-3
Section III	Principles of Operation	1-8
CHAPTER 2	OPERATING INSTRUCTIONS	
Section I	Description and Use of Operator's Controls and Indicators.....	2-1
Section II	Preventive Maintenance Checks and Services (PMCS).....	2-6
Section III	Operation Under Usual Conditions.....	2-13
Section IV	Operation Under Unusual Conditions.....	2-15
CHAPTER 3	Operator Maintenance	
Section I	Lubrication Instructions.....	3-1
Section II	Troubleshooting Procedures	3-2

TABLE OF CONTENTS - CONTINUED

		<u>PAGE</u>
Chapter 4	UNIT MAINTENANCE	
Section I	Repair Parts, Special Tools, TMDE, and Support Equipment	4-1
Section II	Service Upon Receipt	4-1
Section III	Unit PNCS Maintenance Procedures	4-3
Section IV	Troubleshooting Procedures	4-7
Section V	Unit Maintenance Procedures	4-13
Section VI	Preparation for Storage or Shipment	4-127
Chapter 5	DIRECT MAINTENANCE SUPPORT	
Section I	Repair Parts, Special Tools, TMDE, and Support Equipment	5-1
Section II	Direct Support Maintenance Procedures	5-2
Section III	Preparation for Shipment or Storage	5-74
Chapter 6	GENERAL SUPPORT MAINTENANCE	
Section I	Repair Parts, Special Tools, TMDE, and Support Equipment	6-1
Section II	General Support Maintenance Procedures	6-2
Section III	Preparation for Shipment or Storage	6-38
APPENDIX A	REFERENCES	A-1
APPENDIX B	MAINTENANCE ALLOCATION CHART	B-1
APPENDIX C	COMPONENTS OF END ITEM AND BASIC ISSUE ITEMS LIST	C-1
APPENDIX D	ADDITIONAL AUTHORIZATION LIST	D-1
APPENDIX E	EXPENDABLE/DURABLE SUPPLIES AND MATERIALS LIST	E-1
APPENDIX F	TORQUE TABLE	F-1
INDEX	ALPHABETICAL INDEX	Index-1

HOW TO USE THIS MANUAL

GENERAL. This manual contains technical description principles of operation and operating instructions for the Propelling Unit, Outboard Diesel, 165 hp. The manual is divided into six (6) chapters:

Chapter 1. **INTRODUCTION.** Provides general information about the propelling unit, identifies the major components and systems and describes how the components or systems work.

Chapter 2. **OPERATING INSTRUCTIONS.** Identifies operating controls and indicators and explains how to use them. This chapter covers preventive maintenance checks and services (PMCS), how to operate the propelling unit and its equipment during usual and unusual conditions.

Chapter 3. **OPERATOR MAINTENANCE.** References the user to the applicable Department of the Army Technical Manuals (DATMs) and includes Lubricating Instructions, troubleshooting procedures, and authorized operator procedures.

Chapter 4. **UNIT MAINTENANCE INSTRUCTIONS.** References the user to applicable Department of the Army Technical Manuals (DATMs) and includes service upon receipt, Preventive Maintenance Checks and Services (PMCS), troubleshooting procedures, Unit maintenance procedures and preparation for storage or shipment.

Chapter 5. **DIRECT SUPPORT MAINTENANCE.** References the user to applicable Department of the Army Manuals (DATMs) as well as the maintenance procedures authorized for Direct Support Maintenance.

Chapter 6. **GENERAL SUPPORT MAINTENANCE.** References the user to applicable Department of the Army Manuals (DATMs) as well as the maintenance procedures authorized for General Support Maintenance.

WARNINGS, CAUTIONS, AND NOTES. Information is provided throughout the manual which does not fit into a procedural step. This information is in the form of **WARNINGS, CAUTIONS** and **NOTES**. **WARNINGS** are provided where injury may occur to personnel on or near the equipment. **WARNINGS** headings are underlined and overlined, as shown below:

WARNING

Dry cleaning solvent (Federal Specification PD-680), acetone and methyl ethyl ketone (MEK) are toxic and highly flammable. Use only in a well

HOW TO USE THIS MANUAL - Continued

ventilated area. Avoid prolonged breathing of fumes. Keep solvents away from excessive heat, sparks, or open flame. Always wear eye protection and protective clothing when using solvents.

CAUTIONS are provided where equipment may be damaged but no personal injuries should result. The word **CAUTION** is underlined, as shown below:

CAUTION

Do not hold in START position any longer than necessary to start equipment or the starter will overheat.

NOTES highlight or amplify information to operate the equipment, but no equipment damage or personal injury is involved, as shown below:

NOTE

Engine should start within ten (10) seconds.

WARNINGS, CAUTIONS AND NOTES SHOULD NEVER BE IGNORED.

INTERNAL REFERENCES. In this manual, internal referencing is done by paragraph number. For example: Replace flywheel assembly (para. 5- 18a). The note (para. 5-18a) refers you to Chapter 5, paragraph 18a., of this manual.

For quick reference to an item or procedure, use the alphabetical index in the back of this manual.

EXTERNAL REFERENCES. Referencing outside this manual will be by the military publication number. For example: Clean and lubricate (LO5-2010-205-12). The note (LO5-2010-205-12) refers you to the lubrication order for the Propelling Unit.

PROBLEMS AND MALFUNCTIONS. The propelling unit may not work properly during operation. When malfunctions occur, the operator should refer to the appropriate page of the equipment technical manual and look for the problem in the symptom (malfunction) index of the troubleshooting section. This index will direct the operator to identify exactly what is wrong and how to correct it. The procedure may direct the operator to other sections of the manual, such as Maintenance. When the operator has done all that can be done and the problem still exists,

HOW TO USE THIS MANUAL - Continued

the operator will be directed to notify higher maintenance. If there is no procedure provided in the symptom (malfunction) index to correct the problem, the operator should notify the next higher level of maintenance.

APPENDIXES. There are six (6) appendixes that provide additional information needed to operate the Propelling Unit. Various lists of equipment and supplies and other general information are provided. The appendixes are lettered A through F.

INDEX. Items and operations are listed in alphabetical order with appropriate paragraph number(s).

LOCATION TERMS. The terms starboard (STBD), port, forward, and aft are used to describe areas of the vessel and propelling unit. The location terms refer to the right side (STBD), left side (PORT), front (FORWARD), or rear (AFT).

ILLUSTRATIONS AND TEXT. Locator views are included wherever necessary. An arrow is used to show the general location of the equipment referred to in the text. An arrow connects the point of interest to an overall view of the equipment. Call out numbers identifying parts appear on the illustrations and in parentheses in the text.

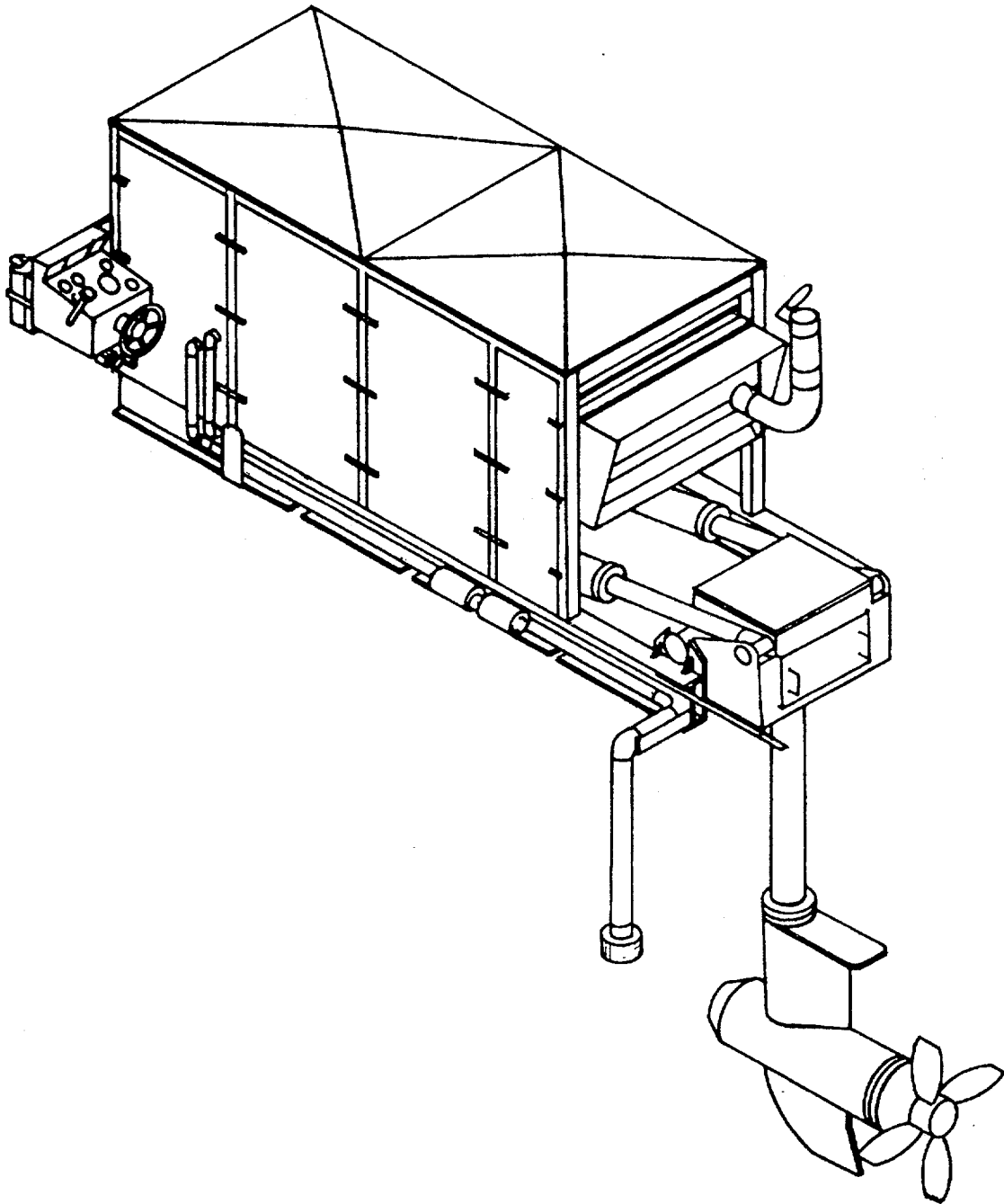

Propelling Unit, Outboard

CHAPTER 1

INTRODUCTION

	<u>PAGE</u>
Section I General Information	1-1
Section II Equipment Description and Data	1-3
Section II Principles of Operation	1-8

Section I. GENERAL INFORMATION

1-1. SCOPE

- a. Type of Manual.** Operator, Organizational, Direct Support, and general Support Maintenance Manual.
- b. Model Number and Equipment name.** TMOT-OD-250A, 165 hp Propelling Unit, Outboard, Diesel.
- c. Purpose of Equipment.** Provides main propulsion needed for the barge.

1-2. MAINTENANCE FORMS, RECORDS, AND REPORTS. Department of the Army forms and procedures used for equipment maintenance will be those prescribed by DA PAM 738-750, the Army Maintenance Management System (TAMMS).

1-3. DESTRUCTION OF ARMY MATERIAL. Refer to TM 750-244-3 for instructions covering the destruction of Army material to prevent enemy use.

1-4. REPORTING EQUIPMENT IMPROVEMENT RECOMMENDATION (EIR's). If your propelling unit needs improvement, let us know. Send us an EIR. You, the user, are the only one who can tell us what you don't like about your equipment. Let us know why you don't like the design or performance. Put it on an SF368 (Product Quality Deficiency Report). Mail it to U.S. Army Troop Support Command, ATTN: AMSTR-MOF, 4300 Goodfellow Boulevard, ST. Louis, MO 63120-1798. We'll send you a reply.

1-5. PREPARATION FOR STORAGE OR SHIPMENT. Administrative storage of equipment issued to and used by Army activities will have preventive maintenance performed in accordance with the Preventive Maintenance Checks and Services (PMCS) before stowing. When removing the equipment from administrative storage, the PMCS should be performed to assure operational readiness. Disassembly, and repacking of equipment for shipment or short term storage, are covered in paragraph 4-68, 5-33 and 6-15.

a. Placement of equipment in administrative storage should be for short periods of time when a storage of maintenance effort exists. Items should be in mission readiness within twenty-four (24) hours or within the time factors as determined by the directing authority. During the storage period, appropriate maintenance records will be kept.

b. Before placement of equipment in administrative storage, current maintenance services and equipment serviceable criteria (ESC) evaluations should be completed, shortcomings and deficiencies should be corrected, and all modification work orders (MWOs) should be supplied.

c. Storage site selection. Inside storage is preferred for items selected for administrative storage. If inside storage is not available, trucks, vans, conex containers and other containers may be used.

1-6. WARRANTY. Thrustmaster of Texas warrants that the goods of their manufacture are free from any defects due to faulty design, materials and/or workmanship. Should any defects in design, material and/or workmanship develop within twelve (12) months from the date of commencement of operation of the goods, but not later than eighteen (18) months from the date of shipment, the Government Warranty Office (TROSCOM WARCO) shall notify Thrustmaster of such defects and Thrustmaster shall either replace or repair the defective components at their option. This warranty will be performed free on board (FOB) at vendor's factory. Freight, insurance of defective components as well as any consequential damages are specifically excluded. Moreover, the fitness of the equipment for the Government's purpose is specifically excluded from Thrustmaster's warranty.

1-7. ABBREVIATIONS.

Ac	Alternating current
assy	Assembly
c	Centigrade
dc	Direct current
deg	Degrees
F	Fahrenheit
horiz	Horizontal
hp	Horsepower
Hz	Hertz
kw	Kilowatts
lb	Pound
lb-ft	Foot-pound force
min	Minimum
mm	Millimeters
para	Paragraph
psi	Pound per square inch
rpm	Revolutions per minute
Vac	Volts alternating current

Section II. EQUIPMENT DESCRIPTION AND DATA

1-8. CHARACTERISTICS, CAPABILITIES, AND FEATURES.

- a. Diesel engine powered.
- b. Provides 4500 pounds thrust.
- c. Provides controlled directional propulsion power.
- d. Operates at a nominal 2400 RPM.
- e. Engine electrically started.

1-9. LOCATION AND DESCRIPTION OF MAJOR COMPONENTS.

- a. Propelling Unit (Starboard Side). (Figure 1-1)..

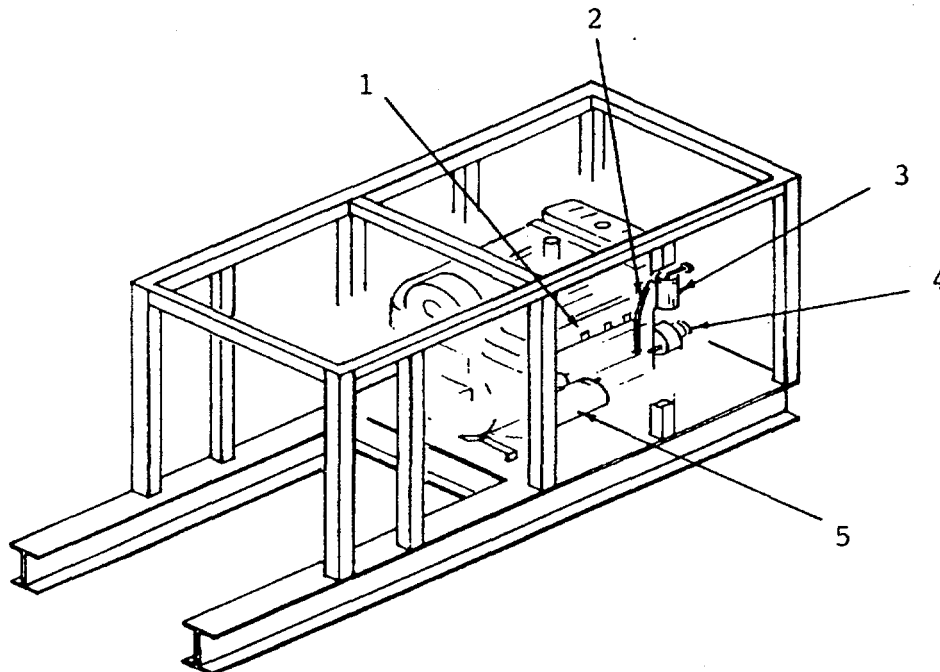

Figure 1-1. Starboard Side View.

(1) Exhaust Manifold. The exhaust manifold (1) provides the means to remove exhaust fumes from the engine.

(2) Oil Level Dipstick. The oil level dipstick (2) is mounted on the side of the engine block and provides means of checking the oil level in the engine.

(3) Fuel Filter. The fuel filter (3) is a replaceable filter unit and filters the fuel to remove suspended particles of dirt and debris.

1.9. LOCATION AND DESCRIPTION OF MAJOR COMPONENTS - Continued.

(4) Alternator. The alternator (4) is belt driven from the front pulley and provides the voltage necessary to recharge the 12V dc starting battery.

(5) Starter. The starter (5) is used to start the diesel engine.

b. Propelling Unit (Port Side). (Figure 1-2).

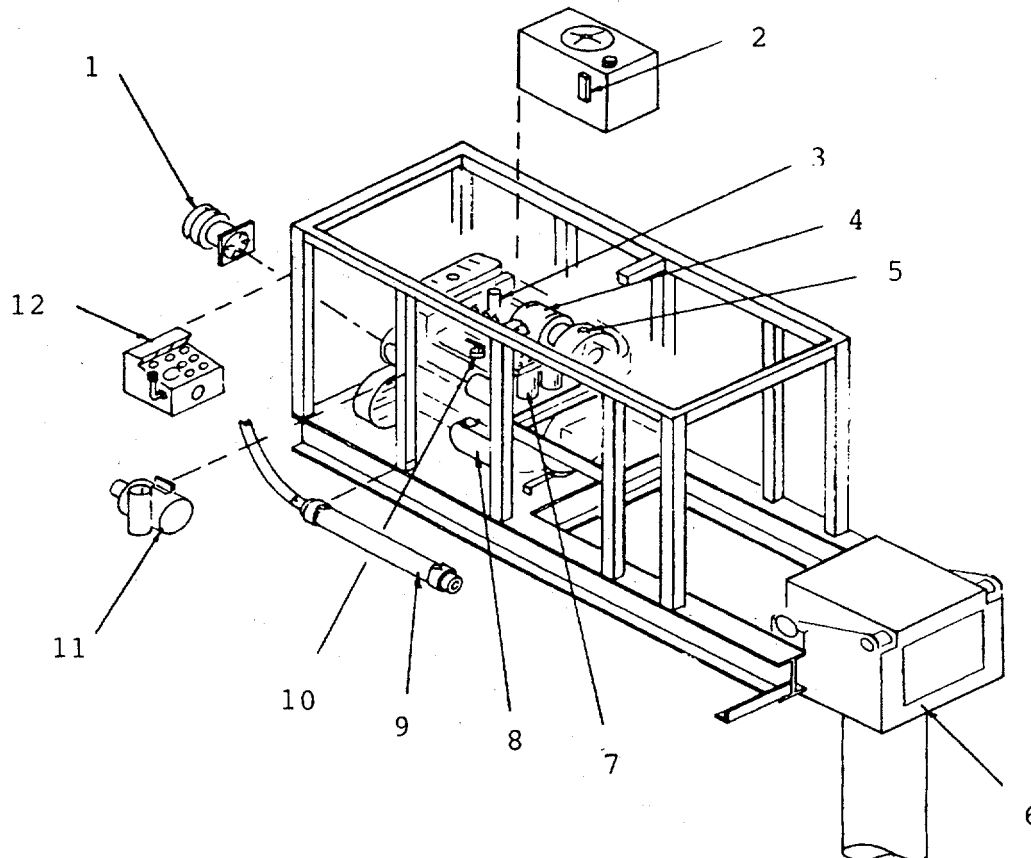

Figure 1-2. Propelling Unit, Port Side View.

(1) Water Pump. The fresh water pump (1) is gear driven and pumps the engine coolant through the engine, oil coolers, and heat exchanger.

(2) Oil Level Gage. The oil level gage (2), mounted on the hydraulic oil reservoir, provides a visual reference as to the oil level in the reservoir.

(3) Governor. The governor (3) is used to regulate the speed of the engine.

(4) Air Filter. The air filter (4) filters the incoming air and removes dirt and debris.

1-9. LOCATION AND DESCRIPTION OF MAJOR COMPONENTS - Continued.

(5) Turbo. The turbo (5) draws air through the air filters, compresses the air and feeds it to the cylinders.

(6) Outdrive. The outdrive (6) contains the components needed to transmit power to the propeller.

(7) Oil Filter. The engine oil filter (7) is a replaceable unit and filters out dirt and debris that may be suspended in the engine lubricating oil.

(8) Engine Oil Cooler. The engine oil cooler (8) uses the engine coolant to cool the engine oil.

(9) Heat Exchanger. The heat exchanger (9) uses raw water to cool the hydraulic oil.

(10) Oil Filler Cap. The oil filler cap (10) covers the opening used to add oil to the engine.

(11) Raw Water Pump. The raw water pump (11) is belt driven from the front crankshaft pulley and pumps cooling water from the sea to the heat exchangers.

(12) Control Panel. The control panel (12) contains the engine starter switch, the engine water temperature gauge, the ampere meter (indicates battery charging and discharging), the engine oil pressure gauge, and the engine stop switch. A tachometer is located on the instrument panel, along with the direction indicator and propulsion and steering controls.

1-10. EQUIPMENT DATA. (Table 1-1).

Table 1-1. Equipment Data

CHARACTERISTICS	REFERENCE DATA
GENERAL ENGINE DATA	
Manufacturer	Caterpillar Peoria, Illinois
Model	3208 DIT
Type	4 Cycle Diesel
Number of Cylinders	8
Bore	4.50 inches (114 mm)
Stroke	5 inches (127 mm)
Compression Ratio	16.5 to 1
Displacement	636 cubic inches (10.4 liters)
Firing Order	1-2-7-3-4-5-6-8

Table 1-1. Equipment Data - Continued

CHARACTERISTICS	REFERENCE DATA
Number of Main Bearings	5
Number of Valves per Cylinder	2
Cooling	Liquid Heat Exchanger
Horsepower (Maximum Speed)	255 HP
Maximum Speed	2400 RPM
LUBRICATION SYSTEM	
Oil Pressure	43 psi at idle 63 psi at maximum rpm
Oil Capacity	16 quarts
COOLING SYSTEM	
Coolant Capacity	58 Quarts
Maximum Outlet Temperature	210 Degrees F.
Maximum Inlet Temperature	165 Degrees F.
Minimum Recommended Pressure	7 psi
EXHAUST SYSTEM	
Exhaust Manifold Type	Water Cooled
Maximum Back Pressure	27 Inches of Water
HYDRAULIC SYSTEM	
Maximum Propulsion Pressure	4000 psi
Minimum Charge Pressure	200 psi
Maximum Steering Pressure	2000 psi
Maximum Suction Filter Vacuum	5 inches of Mercury
Maximum Discharge Filter Pressure	15 psi
FUEL SYSTEM	
Maximum Supply Line Restriction	8 inches Mercury
Maximum Return Line Restriction	8 inches Mercury
Normal Fuel Pressure	30 psi
PROPELLER	
Diameter	48 inches
Pitch	32 inches
Number of Blades	Four

1-11. SAFETY, CARE, AND HANDLING. Safety precautions must be observed at all times while performing maintenance. General **WARNINGS** and first-aid data appear in the front of this manual. Review all safety information before starting any task. Carefully read through an entire maintenance procedure before performing any maintenance function. Make sure the task can be done safely. All **WARNINGS, CAUTIONS,** and **NOTES** are of great importance to your safety and the safety of the equipment.

Section III. PRINCIPLES OF OPERATION

1-12. GENERAL.

a. The diesel engine is an internal combustion power unit, whereby energy of burning fuel is converted into work in the cylinders of the engine.

b. In the diesel engine, air is compressed in the cylinders. After the air has been compressed, a charge of fuel is sprayed into the cylinders. Ignition is accomplished by the heat of compression.

1-13. BASIC BLOCK.

a. **Cylinder Block.** The cylinders are a part of the cylinder block. There are no replaceable cylinder liners. The cylinders can be machined (bored) up to .040 in. (1.02 mm) oversize for reconditioning. The cylinders are arranged in two (2) banks of four (4) cylinders each. The cylinder banks are at 90 degree angles to each other. There are five main bearings in the block to support the crankshaft.

b. Cylinder Head and Valves.

(1). There is one cylinder head for each side (bank) of the engine. One intake and one exhaust valve is used for each cylinder. The valve guides are a part of the cylinder head and cannot be replaced. A valve seat insert is used for the exhaust valve and can be replaced.

(2). The valves and valve system components control the flow of inlet air and exhaust gases into and out of each cylinder during engine operation.

(3). The intake and exhaust valves are opened and closed by movement of the crankshaft, camshaft, cam followers, push rods, rocker arms and valve springs. Rotation of the crankshaft causes rotation of the camshaft. The camshaft gear is driven by, and timed to, a gear on the front of the crankshaft. When the camshaft turns, the cams on the camshaft cause the cam followers to go up and down. This movement makes the push rods move the rocker arms. The movement of the rocker arms will make the intake and exhaust valves in the cylinder head open and close according to the firing order (injection sequence) of the engine. Two valve springs for each valve help to hold the valves in the closed position.

(4). There is one intake and one exhaust valve for each cylinder. The valve seat for the intake valve is machined in and part of the cylinder head. The valve guide bore is machined in and a part of the cylinder head.

c. **Pistons, Rings, and Connecting Rods.**

(1) The pistons have two rings which are located above the piston pin bore. There is one compression ring and one oil control ring. The oil ring is made in one piece and has an expansion spring behind it. The compression ring is also one piece and fits into an iron band cast into the piston. The piston pin is held in place by two snap rings which go into grooves in the piston pin bore.

(2) The connecting rod is installed on the piston with the boss on the connecting rod on the same side as the crater in the piston. The connecting rod bearings are held in location with a tab that goes into a groove in the connecting rod.

d. Crankshaft. The force of combustion in the cylinders is changed to usable rotating power by the crankshaft. A gear on the front of the crankshaft turns the engine camshaft gear and the engine oil pump.

1-14. **TURBOCHARGER.**

a. The watercooled turbocharger is supported by the exhaust manifold at the rear of the engine. All the exhaust gases from the diesel engine go through the turbocharger. The exhaust gases enter the turbine housing and go through the blades of a turbine wheel causing the turbine wheel and compressor wheel to turn. When the compressor wheel turns, it pulls filtered air from the air cleaner through the compressor housing air inlet. The air is put in compression by action of the compressor wheel and is pushed to the inlet manifold of the engine. When the engine load increases, more fuel is injected into the engine cylinders. The volume of exhaust gas increases which causes the turbocharger turbine wheel and compressor impeller to turn faster. The increased RPM of the impeller increases the quantity of inlet air. As the turbocharger provides additional inlet air, more fuel can be burned. This results in more horsepower from the engine.

b. Maximum RPM of the turbocharger is controlled by the fuel setting, the high idle speed setting and the height above sea level at which the engine is operated.

c. The bearings for the turbocharger use engine oil for lubrication. The oil comes in through the lubrication inlet passage and goes through passages in the center section for lubrication of the bearings. Oil from the turbocharger goes out through the lubrication outlet passage in the bottom of the center section and goes back to the engine lubrication system.

1-15. **FUEL SYSTEM.**

a. The sleeve metering fuel system is a pressure type fuel system. The name for the fuel system is from the method used to control the amount of fuel sent to the cylinders. This fuel system has an injector pump for each cylinder of the engine. It also has a fuel

transfer pump on the front of the injector pump housing. The governor is on the rear of the injection pump housing.

b. The drive gear for the fuel transfer pump is on the front of the camshaft for the injection pumps. The carrier for the governor weights is bolted to the rear of the camshaft for the injection pumps. The injection pump housing has a bearing at each end to support the camshaft. The camshaft for the sleeve metering fuel system is driven by the timing gears at the front of the engine.

c. The injection pumps, lifters and rollers, and the camshaft are all inside the pump housing. The pump housing and the governor housing are full of fuel at transfer pump pressure (fuel system pressure).

d. The fuel system has governor weights, a thrust collar and two governor springs. One governor spring is for high idle and the other governor spring is for low idle. Rotation of the shaft for governor control, compression of the governor springs, movement of connecting linkage in the governor and injection pump housing controls the amount of fuel sent to the engine cylinders.

e. Fuel from the fuel tank is pulled by the fuel transfer pump through the fuel filter. From the fuel filter the fuel goes to the housing for fuel injection pumps. The fuel goes into the housing at the top and goes through inside passages to the fuel transfer pump.

1-16. AIR INLET AND EXHAUST SYSTEM.

a. The air inlet system is on the top side of the engine. The air cleaner goes on an air inlet pipe. The air inlet pipe sends air to both cylinder heads. The air inlet pipe cannot be turned end for end because the mounting flange for the air cleaner has a small angle toward the front of the engine.

b. The air inlet manifolds are made as a part of the cylinder heads. The air inlet openings and the design of the combustion chamber supply the air needed for complete combustion.

c. The exhaust system is on each side of the engine. The exhaust manifolds are along the outside of the cylinder heads. The exhaust manifold for the right side of the engine will not go on the left side of the engine. The exhaust manifold for the left side of the engine will not go on the right side of the engine.

1-17. LUBRICATION SYSTEM.

a. The lubrication system uses a six (6) lobe, rotor type oil pump. Bolts hold the cover of the oil pump on the front cover of the engine. A gear on the crankshaft drives the outer rotor. The outer is supported by a bearing in the front cover of the engine. The inner rotor is mounted on a short shaft in the front cover of the engine. The inner rotor is driven by the outer rotor.

b. The pump can put more oil into the system than needed. The oil that is not needed bypasses the system through a relief valve.

1-18. COOLING SYSTEM. The water pump is installed on the front cover of the engine and is driven by V-belt from the crank shaft pulley. As the coolant goes from the water pump, it divides and goes through the inside passages in the front cover of the engine to the cylinder block and up to the cylinder heads. From the cylinder heads, the coolant goes forward through orifices to the front cover of the engine. Part of the coolant on the left side of the cylinder block goes to the cooler for engine oil. The remainder goes to the bottom left opening in the water cooled turbocharger. Coolant leaves the turbocharger from two lines at the top and goes to the watercooled turbocharger support. The coolant then goes to the front cover of the engine. From the front cover of the engine, the coolant either goes to the inlet for the water pump or to the expansion tank. If the coolant is cold (cool), the water temperature regulators will be open.

1-19. ELECTRICAL SYSTEM. The electrical system has three (3) separate circuits: the charging circuit, the starting circuit and the low amperage circuit. Some of the electrical system components are used in more than one circuit. The batteries, circuit breaker, ammeter, cables and wires from the battery are all common in each of the circuits.

a. The charging circuit is in operation when the engine is running. An alternator makes electricity for the charging circuit. A voltage regulator in the circuit controls the electrical output to keep the battery at full charge.

b. The starter circuit is in operation only when the start switch is activated.

c. The low amperage circuit and the charging circuit are both connected to the same side of the ammeter. The starting circuit connects to the opposite side of the ammeter.

1-20. MAIN HYDRAULIC PUMP.

a. The axial piston pump features advanced design concepts providing smooth controlled power in a compact package. The axial piston pump uses a rocker cam and cradle stroking control to vary displacement. A vane actuator with a rotary servo operates the stroking control thus varying flow. A double gerotor pump mounted in the main port-block provides independent servo and replenishing flow in the closed loop. The basic pump includes a rotary servo input control and compensator override.

b. The main pump, through the use of the controls on the control panel, provides the hydraulic power required to turn the propeller. The piggyback mounted auxiliary pump provides power for steering, and for lifting the propeller out of the water.

1-21. CONTROL PANEL AND CONTROLS.

a. The control panel is located on the port side of the propelling unit. The lift-tilt control valve on the lower-right side to the control panel, and the forward-reverse control valve located on the left side of the control panel, are manually operated. The tilt valve controls the kick-up of the outdrive assembly and the forward-reverse lever controls the propeller speed in forward and reverse direction.

b. The steering wheel is connected to a power steering control unit. The steering control unit is fully fluid linked. This means there is no mechanical connection between the steering unit, the pump and the steering motor. The unit consists of a manually operated directional control valve and servo feedback meter element in a single body. The close coupled, rotary action valve performs all necessary fluid directing functions with a small number of moving parts. The manually actuated valve is coupled with the mechanical drive to the meter gear. The control is lubricated and protected by the power fluid in the system and can operate in many environments. Power is directed through hydraulic hoses to the steering motor located in the upper outdrive housing.

1-22. OUTDRIVE ASSEMBLY. The outdrive assembly receives hydraulic power, transmitted through hoses, and performs all operating functions required to maneuver the watercraft. The lift-tilt is accomplished by transmitting fluid power to the two hydraulic cylinders connecting the power unit and the outdrive assembly. The steering is controlled by power transmitted to a hydraulic motor with a pinion geared output shaft. This pinion drives a large gear attached to the column, which turns when hydraulic fluid is allowed to pass through the motor. The hydraulic power to turn the propeller first passes through a swivel assembly in the upper housing. The fluid then flows through hoses to a hydraulic motor in the thruster housing. The output shaft of the motor is coupled mechanically to the propeller shaft, which turns the propeller.

CHAPTER 2
OPERATING INSTRUCTIONS

		<u>Page</u>
Section I	Description and Use of Operator's Controls and Indicators	2-1
Section II	Preventative Maintenance Checks and Services (PMCS)	2-6
Section III	Operation Under Usual Conditions	2-13
Section IV	Operation Under Unusual Conditions	2-15
 Section I.	 DESCRIPTION AND USE OF OPERATOR'S CONTROLS AND INDICATORS	

2-1. CONTROL PANEL. Figure 2-1. The control panel is located on the port side of the power unit.

- a. The starting switch (12), and key, when turned, is used to start the engine.
- b. The water temperature gauge (2) is used to monitor engine water temperature.
- c. The oil pressure gauge (18) is used to monitor engine oil pressure.
- d. The ammeter (17) is used to monitor engine battery and charging system.
- e. The throttle (13) is turned to set engine speed.

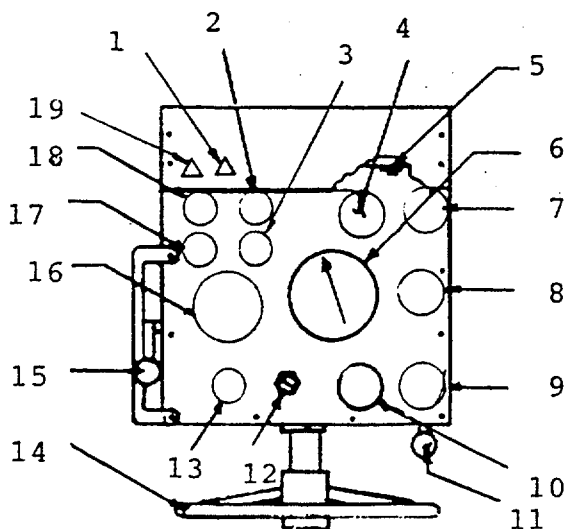

Figure 2-1. Control Panel Controls and Indicators.

- f.** The tachometer (16) is used to monitor engine rpm.
- g.** The suction filter (10) and return filter (9) gauge are used to monitor the condition of these filters.
- h.** The steering gauge (8) monitors pressure in the hydraulic steering system.
- i.** The direction indicator (7) locates the relative location of the propeller (direction of thrust).
- j.** The propulsion gauge (4) monitors hydraulic pressure of the main pump used for thrust.
- k.** The charge gauge (6) registers pressure of the booster pump.
- m.** The forward-reverse direction valve lever (15) controls direction of thrust by reversing propeller direction from clockwise to counterclockwise. This lever also proportionally controls the magnitude of thrust.
- n.** The lift-tilt valve (11) located under the control panel is used to tilt the outdrive out of the water.
- o.** The steering wheel (14) controls the outdrive slewing feature steering the vessel to port or starboard.
- p.** The 15 amp fuses (19) protect the instrumentation on the control panel.
- q.** The light switch (1) turns the light on or off on the control panel.
- r.** The hour meter (3) registers the total number of hours the engine has been run.

2-2. HYDRAULIC OIL LEVEL GAUGE (Figure 2-2). The oil level gauge (1) is located on the side of the reservoir (2) and is used to monitor the amount of oil available for the hydraulic system.

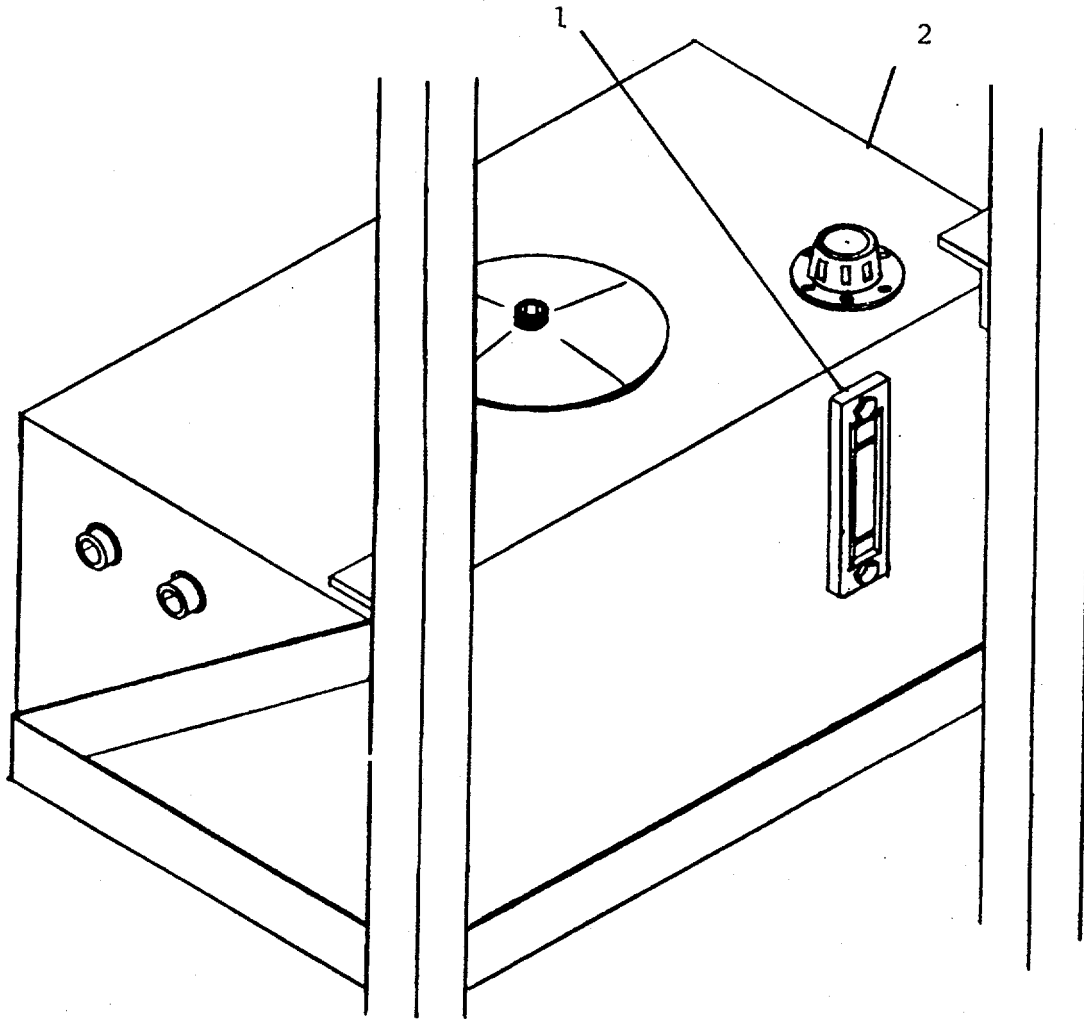

Figure 2-2. Hydraulic Oil Level Gauge.

2-3. ENGINE OIL LEVEL DIPSTICK (Figure 2-3). The oil level dipstick (1) is located on the side of the engine (2) and is used to check engine oil level when the engine is not running.

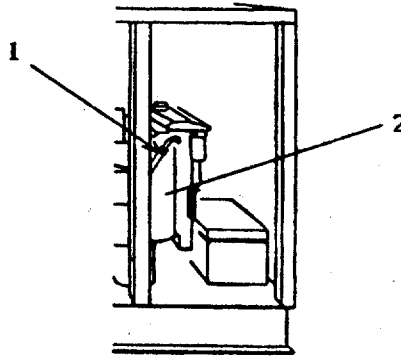

Figure 2-3. Engine Oil Level Dipstick.

2-4. HYDRAULIC OIL SHUT-OFF VALVE (Figure 2-4). The hydraulic oil shut-off valve (1) stops the flow of oil to the entire hydraulic system.

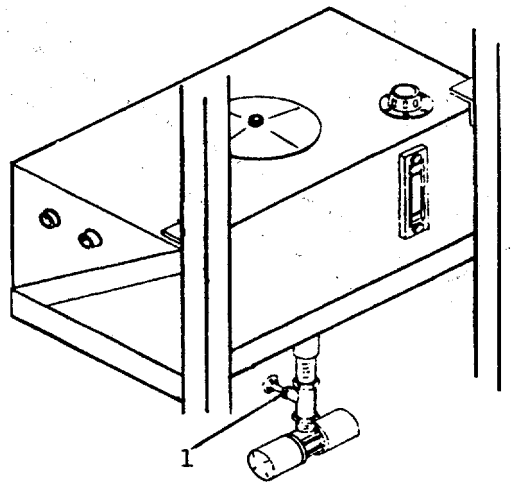

Figure 2-4. Hydraulic Oil Shut-off Valve.

2-5. FUEL TANK (Figure 2-5). The fuel tank (1) contains the diesel engine fuel and the fuel level gauge (2) indicates the amount in the tank.

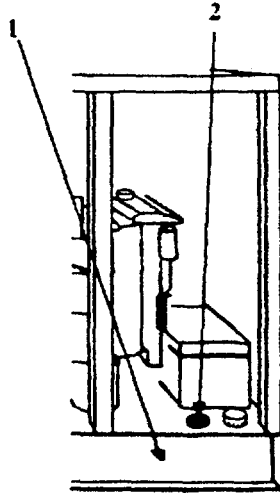

Figure 2-5. Fuel Tank.

2-6. EXPANSION TANK (Figure 2-6). The expansion tank (1) contains a water/glycol solution used to cool the engine.

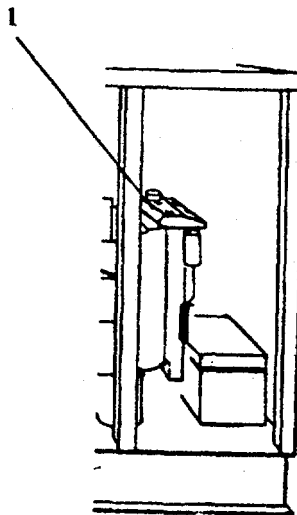

Figure 2-6. Expansion Tank.

SECTION II. OPERATOR/CREW PREVENTIVE MAINTENANCE CHECKS AND SERVICES (PMCS)

2-7. INTRODUCTION

a. General. To ensure that the Propelling Unit is ready for operation at all times, it must be systematically inspected so that defects may be discovered and corrected, preventing serious damage or failure. DA Form 2404 (Equipment Inspection and Maintenance Worksheet) will be used for the PMCS. All uncorrected faults will be transcribed to DA Form 2407 (Maintenance Request) and the appropriate log. PMCS will be accomplished as outlined in Table 2-1. The Propelling Unit will be serviced in accordance with the intervals outlined in the PMCS table.

(1) Before You Operate. Required preventive maintenance will be performed before operating (B). Any deficiencies noted will be corrected before equipment operation. Observe all **WARNINGS** and **CAUTIONS**.

(2) While You Operate. During operating services (D) is a check on the vessel's performance. If any deficiencies are noted that will result in damage to the equipment, operation of that equipment will be stopped. Observe all **WARNINGS** and **CAUTIONS**.

(3) After You Operate. After operated services (A) are the basic preventive maintenance services. Services will be performed at intervals based on normal operation of the equipment. Observe all **WARNINGS** and **CAUTIONS**.

(4) If Your Equipment Fails to Operate. Report any deficiencies using the proper forms. See DA Pam 738-750.

b. PMCS Columnar Entries.

(1) Item Number Column.

(2) Interval Column. The interval column of the PMCS table indicates when to do a certain check or service.

(3) Item To Be Inspected Column.

(4) Item To Be Inspected Procedure Column. The procedure column of the PMCS table instructs how the required checks and services are performed. Carefully follow these instructions. If the required tools are not available or if the procedure directs, have Unit Maintenance do the work.

(5) Equipment Is Not Ready/Available If: Column. This column tells you when and why your equipment cannot be used.

NOTE

The terms "Ready/Available" and "Mission Capable" refer to the same status. Equipment is on hand and is able to perform its combat mission. See DA PAM 738-750.

(6) Leakage Classification. Leakage definitions for operator/crew PMCS shall be classified as follows:

(a) CLASS I. Seepage of fluid (as indicated by wetness or discolorations) not great enough to form drops.

(b) CLASS II. Leakage of fluid great enough to form drops but not enough to cause dripping from the item being inspected.

(c) CLASS III. Leakage of fluid great enough to form drops that fall from the item being inspected.

CAUTION

Equipment operation is allowable with minor leakage (Class I or II). Of course, consideration must be given to the fluid capacity in the item -being inspected. When in doubt, notify your supervisor.

When operating with Class I or Class II leaks, continue to check fluid levels as required in your PMCS. Class III leaks should be reported to your supervisor or to Unit Maintenance.

Table 2-1. Operator/Crew Preventive Maintenance Check and Services

Note: Within designated interval, these checks are to be performed in order listed.

B-Before
D-During

A-After
W-Weekly

M-Monthly

ITEM NO.	INTERVAL					Item To Be Inspected	Procedures Check for and have repaired or adjusted	EQUIPMENT IS NOT READY/AVAILABLE IF:
	B	D	A	W	M			
1	•		•			Oil Level	 <p>With the engine shut down, remove the dipstick (2), wipe it clean and reinsert. Remove the dipstick and check the oil level. Oil level should be between the marks. If not, add oil through oil filter (1). (LO 5-2010-205-12).</p>	<i>Oil level low.</i>
2	•	•	•			Fuel Lines	<p>Visually inspect all fuel lines (suction, return, and crossover), the pump and filter for leaks.</p>	<i>Class II or III leaks evident.</i>

Table 2-1. Operator/Crew Preventive Maintenance Check and Services

Note: Within designated interval, these checks are to be performed in order listed.

ITEM NO.	INTERVAL					Item To Be Inspected	Procedures Check for and have repaired or adjusted	EQUIPMENT IS NOT READY/AVAILABLE IF:
	B	D	A	W	M			
3	•		•			Coolant Level	<p>WARNING Use caution when removing the radiator cap while the engine is still hot.</p> <p>WARNING To prevent burns and to prevent damage to the engine, do not add coolant to an overheated engine. Allow the engine to cool first.</p> <p>Check the coolant level and maintain it within 1" from the top of the heat exchanger tank. Add fresh water and antifreeze (1/2 water and 1/2 antifreeze mixture) as needed.</p>	Coolant level more than 1-inch from top. Temperature over 190 degree F.
4	•	•	•			Coolant Lines	Inspect all coolant lines and components (pumps, oil coolers, heat exchanger, and exhaust manifold) for leaks.	Class II or III leaks evident.
5		•				Raw Water Pumping System	 <p>Observe water flow thru filter (1) and out of discharge pipe (2).</p>	No water flow from discharge Pipe.

Table 2-1. Operator/Crew Preventive Maintenance Check and Services

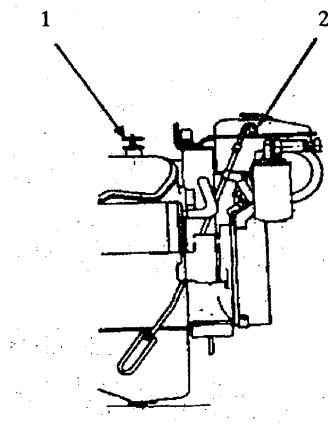
Note: Within designated interval, these checks are to be performed in order listed.

ITEM NO.	INTERVAL					Item To Be Inspected	Procedures Check for and have repaired or adjusted	EQUIPMENT IS NOT READY/AVAILABLE IF:
	B	D	A	W	M			
6	•	•	•			Exhaust System	<p>WARNING</p> <p>Use caution when working around the exhaust system. Can be hot to the touch.</p> <p>Check the exhaust manifold retaining nuts, exhaust clamp and all other parts for tightness and leaks.</p>	Visible or noisy exhaust, leaks exhaust, leaks evident
7		•				Oil Pressure	Check that the oil pressure as read on oil pressure gage, is maintained between 43 And 65 psi.	Oil Pressure less than 43 psi.
8	•		•			Reservoir Oil Level	 <p>Check that the oil is not lower than the line in the oil level gage (1). Add oil if needed. (LO 5-205-2010-12)</p>	Oil not visible in oil gage.
9				•		Drove Belt (Alternator)	Check that belt flex is not more than 3/4" or less than 1/2".	Belts have cracks.

Table 2-1. Operator/Crew Preventative Maintenance Check and Services

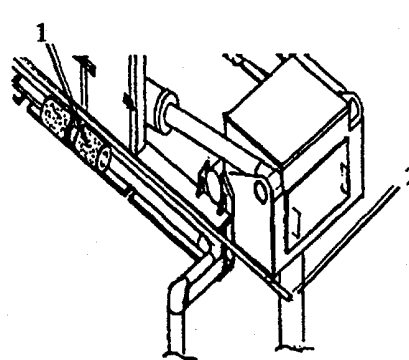
Note: Within designated interval, these checks are to be performed in the order listed.

ITEM NO.	INTERVAL					Item To Be Inspected	Procedures Check for and have repaired or adjusted	EQUIPMENT IS NOT READY/AVAILABLE IF:
	B	D	A	W	M			
10	•	•	•			Hydraulic Hoses	Visually inspect all hydraulic hose line signs of leak.	Class II or III leak evident.
11			•			Air Filter	 <p>If indicator (4) is green, the filter is dean. When indicator turns red indicating filter is dirt, loosen thumbscrew (1), rotate arm (2), remove and replace element (3).</p> <p>WARNING Use caution when removing the radiator cap while the engine is still hot.</p>	
12	•		•			Expansion Tank and Heat Exchanger	Check for leaks and worn gaskets on cap	Class II or III leaks evident. Zinc anode missing.
13		•				Emergency Shutdown	Check the operation of the emergency shutdown system. Depress switch on control panel with engine running.	Shutdown not functional.
14					•	Engine Mounts	Check engine mounting bolts and mounting pads for damage, missing parts and	Bolts damaged, missing, or loose. looseness. damage or missing.

Table 2-1. Operator/Crew Preventative Maintenance Check and Services

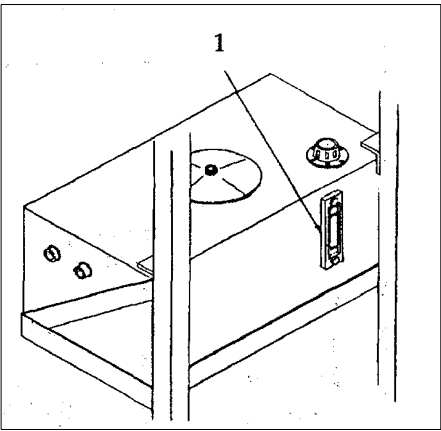
Note: Within designated interval, these checks are to be performed in the order listed.

ITEM NO.	INTERVAL					Item To Be Inspected	Procedures Check for and have repaired or adjusted	EQUIPMENT IS NOT READY/AVAILABLE IF:
	B	D	A	W	M			
15		•				Hydraulic Filters	Check suction and return filter gages. When suction filter gage shows 3 inches mercury of vacuum at full engine speed, or return filter gage shows 10 psi, change Filters immediately.	Suction filter gage reads 3" mercury or more. Return filter gage reads 10 psi or more.
16						• Engine Heat Exchange	Check zinc anode for corrosion <u>CAUTION</u> Operating the unit with the hydraulic oil valve closed will cause serious damage to the pump.	Zinc anode missing.
17		•				Hydraulic Valve	Open the hydraulic valve completely beneath the reservoir before operating.	Valve Closed.

Section III. OPERATION UNDER USUAL CONDITIONS**2-9. STARTING.**

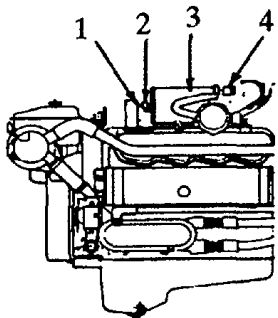
- a. Perform all of the Before (B) PMCS (para. 2-7).

CAUTION

If engine is operated with the hydraulic oil shut-off valve closed, serious damage to the main pump will occur.

- b. Be sure the hydraulic oil shut-off valve is open.

CAUTION

Damage to starter could result if starter is engaged and engine does not start within 15 seconds.

- c. With forward-reverse valve lever in neutral (center), turn start switch firmly until engine starts. If engine fails to start within 15 seconds, release starting switch and wait 5 seconds before attempting to start again.

CAUTION

Operating engine without oil pressure will result in engine being damaged.

2-10. RUNNING.**CAUTION**

Immediately upon starting engine, check hydraulic charge pressure gauge on control panel. Charge pressure should be approximately 300 psi. If charge pressure is less than 200 psi., shut engine down immediately and notify Unit Maintenance.

NOTE

Engine oil pressure should be between 43 and 65 psi.

- a. Oil Pressure. Observe oil pressure gauge immediately after starting engine. If there is no oil pressure within 15 seconds after start-up, shut engine down, and notify Unit Maintenance.

NOTE

Normal operating temperature (coolant) is 160 to 185 F (71 to 85 C).

- b. Warm-up.** Run engine at part throttle and no load for approximately 5 minutes to allow the engine to warm up before applying a load.
- c. Inspection.** While engine is running at operating temperature, perform all during (D) PMCS operations.
- d. Idling.** When prolonged engine idling is necessary (no-load), maintain at least 800 rpm.
- e.** Check the location of the propeller by observing the direction indicator.
- f.** Advance throttle knob slowly until the tachometer reads desired speed, but not to exceed 2400 rpm.
- g.** Insure the propeller stem is at an angle that will allow the propeller to be fully water covered, but still permitting draft in shallow water.
- h.** Engage forward-reverse lever to desired direction and magnitude of propulsion.
- i.** Use steering wheel to direct the vessel towards desired destination.

2-11. STOPPING.

- a. Normal Stopping.** Remove load by positioning the forward reverse lever in its center or neutral position and set throttle to 800 rpm. Allow engine to run at this speed for four or five minutes and then turn the key to stop position.
- b. Emergency Stopping.** Press down on emergency stop lever. c. Inspection. Perform all After (A) PMCS. Check all lines for leaks. Clean as necessary.
- c. Inspection.** Perform all After (A) PMCS. Check all lines for leaks. Clean as necessary.

Section IV. OPERATION UNDER UNUSUAL CONDITIONS**2-12. OPERATION IN EXTREME COLD (below 0 deg C).**

- a. Locate the propelling unit in a shed or building whenever possible. If the unit is operated, protect it from prevailing winds if possible, and cover it with a tarpaulin when not in use.
- b. Lubricate the propelling unit in accordance with the mandatory lubrication instructions in Chapter 3 of this manual and L05-2010-205-12.
- c. Avoid excessive handling and bending of hose lines, which become brittle at low temperatures.
- d. Keep the fuel tank filled with fuel to prevent the formation of ice crystals. Such crystals will clog the fuel system.

2-13. OPERATION IN EXTREME HEAT.

- a. Lubricate in accordance with the mandatory lubrication instructions in Chapter 3 of this manual and LO5-2010-205-12.
- b. Check belt tension frequently. Improper belt tension often results in over-heating.
- c. Fill the fuel tank at the end of each days operation, especially in areas where the temperature drops sharply at night. This will prevent condensate from forming in the fuel tank.
- d. Keep the engine clean. Service the engine air cleaner as often as necessary.

2-14. OPERATION IN SALT WATER AREAS.

- a. Wipe the unit dry at frequent intervals, with particular emphasis on the engine.
- b. If the unit becomes encrusted with salt, wash it with fresh water, taking care not to damage the electrical system with water.
- c. Coat exposed polished or machined metal surfaces with a suitable preservation material after first removing any accumulation of rust.

**CHAPTER 3
OPERATOR MAINTENANCE**

		<u>Page</u>
Section I	Lubrication Instructions	3-1
Section II	Troubleshooting Procedures	3-2

Section I. LUBRICATION INSTRUCTIONS

3-1. LUBRICATION INSTRUCTIONS.

a. General. Keep all lubricants in closed containers and store in a clean, dry place away from external heat. Keep container covers clean and allow no dirt, dust or other foreign materials to mix with the lubricants. Keep all lubrication equipment clean and ready for use.

b. Cleaning. Keep all external parts not requiring lubrication free of lubricants. Before lubricating the equipment, wipe all lubrication points free of dirt and grease. Clean all lubrication points after servicing to prevent the accumulation of foreign matter.

c. Lubrication Points. Service all lubrication points at the proper intervals as specified in L05-2010-205-12. The intervals specified are based on operation under normal conditions. Modifications of the recommended levels may be required under unusual operating conditions.

3-2. LUBRICATION ORDER. For lubrication under any condition, refer to L05-2010-205-12.

Section II. TROUBLESHOOTING PROCEDURES

3-3. GENERAL.

a. The table in this section lists the common malfunction which you may find during operation or maintenance of the propelling unit or its components. You should perform test/inspection and corrective maintenance in the order listed.

b. This manual cannot list all malfunctions that may occur, nor all tests or inspections and corrective actions. If a malfunction is not listed or corrective actions not found, notify your supervisor.

Table 3-1. Operator Troubleshooting

Malfunction
Test or Inspection
Corrective Action
<p>1. Engine Exhaust is Black or Grey.</p> <p>STEP 1. Check for proper grade of fuel. If fuel is of improper grade, drain and then refill tank. If fuel is of proper grade, proceed to step 2.</p> <p>STEP 2. Check for clogged or dirty air cleaner. If air cleaner is clogged or dirty, replace air cleaner element. If air cleaner is not clogged or dirty, notify Unit Maintenance if conditions still exist.</p>
<p>2. Engine Exhaust is Blue.</p> <p>Remove dipstick and check oil level. If oil level is higher than normal, drain crankcase and refill to proper level. If oil level is normal, notify Unit Maintenance.</p>
<p>3. Hard Starting.</p> <p>STEP 1. Check for loose or dirty battery terminal and starter connections. If terminal connections are loose, tighten connections. If terminal connections are dirty, clean connections. If terminal connections are clean and tight, proceed to Step 2.</p>

Table 3-1. Operator Troubleshooting - Continued

Malfunction**Test or Inspection****Corrective Action**

- STEP 2. Check for cracked, broken battery.
 If battery is cracked or broken, replace battery.
 If battery is not defective, proceed to Step 3.
- STEP 3. Check that fuel tank has sufficient fuel to cover the pick-up tube.
 If fuel level is low, fill tank.
 If fuel level is not low, proceed to Step 4.
- STEP 4. Check for loose, restricted, or damaged fuel strainer or filter.
 If fuel strainer or filter is loose, tighten strainer or filter.
 If fuel strainer or filter is restricted or damaged, replace strainer or filter.
 If fuel strainer or filter is not damaged or loose, notify Unit Maintenance.

4. Uneven Running or Frequent Stalling.

- Check for sufficient fuel supply.
 If fuel supply is low, fill tank.
 If fuel supply is adequate, notify Unit Maintenance.

5. Lack of Power.

- STEP 1. Check for clogged or dirty air cleaner element.
 If air cleaner is clogged or dirty, replace air cleaner.
 If air cleaner is not clogged or dirty, proceed to Step 2.
- STEP 2. Check that fuel tank has sufficient fuel to cover the pick-up tube.
 If fuel level is low, fill tank.
 If fuel level is not low, proceed to Step 3.
- STEP 3. Check for loose, restricted, or damaged fuel strainer or filter.
 If fuel strainer or filter is loose, tighten strainer or filter.
 If fuel strainer or filter is restricted or damaged, replace strainer or filter.
 If fuel strainer or filter is not damaged or loose, notify Unit Maintenance.

Table 3-1. Operator Troubleshooting - Continued

Malfunction
Test or Inspection
Corrective Action

6. Above Normal Coolant Temperature.

STEP 1. Inspect for collapsed or disintegrated hoses.
If hoses are collapsed or disintegrated, notify Unit Maintenance.
If hoses are not collapsed or disintegrated, proceed to Step 2.

STEP 2. Check coolant level in heat expansion tank.
If coolant is below filler neck, add coolant (1/2 water and 1/2 anti-freeze).
If coolant level is normal, notify Unit Maintenance.

CHAPTER 4
UNIT MAINTENANCE

		<u>Page</u>
Section I	Repair Parts, Special Tools, TMDE, and Support Equipment	4-1
Section II	Service Upon Receipt	4-2
Section III	Unit PMCS Maintenance Procedures	4-3
Section IV	Troubleshooting Procedures	4-7
Section V	Unit Maintenance Procedures	4-13
Section VI	Preparation for Storage or Shipment	4-128

Section I. REPAIR PARTS, SPECIAL TOOLS; TEST MEASUREMENT, DIAGNOSTIC EQUIPMENT (TMDE); AND SUPPORT EQUIPMENT

4-1. COMMON TOOLS AND EQUIPMENT. For authorized common tools and equipment, refer to the Maintenance Allocation Chart (MAC).

4-2. SPECIAL TOOLS, TMDE, AND SUPPORT EQUIPMENT. Refer to the Repair Parts and Special Tools List (TM 5-2010-205-24P) and to the Maintenance Allocation Chart (Appendix B of this manual) for the special tools, TMDE, and support equipment required.

4-3. REPAIR PARTS. Repair parts are listed and illustrated in the Repair Parts and Special Tools List (TM 5-2010-205-24P) covering Unit Maintenance for this equipment.

Section II. SERVICE UPON RECEIPT**4-4. UNPACKING.**

- a. Remove all metal bands, crating, and plastic sheeting.
- b. Remove plastic sheeting.
- c. Use solvent (Appendix E item 1) to remove all traces of rust prevention compounds, and all traces of masking tape.

4-5. CHECKING UNPACKED EQUIPMENT.

a. Inspect the equipment for damage incurred during shipment. If the equipment has been damaged, report the damage on DD Form 6, Packing Improvement Report.

b. Check the equipment against the packing slip to see if the shipment is complete. Report all discrepancies in accordance with the instructions of DA PAM 738-750 (TAMNS).

c. Check to see whether the equipment has been modified.

4-6. PRELIMINARY SERVICING.

a. Check the crankcase for lubricating oil (Appendix E, item 2).

b. Check the cooling system for fresh water and antifreeze (Appendix E, item 4).

c. Check the hydraulic reservoir for hydraulic oil (Appendix E, item 21).

d. Remove the fuel filter and fuel strainer. Fill both shells with fuel oil and reinstall the fuel filter and fuel strainer.

e. Start the engine and perform a tune-up per Section VI of this chapter.

Section III. PREVENTIVE MAINTENANCE CHECKS AND SERVICES (PMCS)

4-7. GENERAL. To obtain long life and best performance from the propelling unit, you must adhere to the PMCS contained in this section. The required PMCS are to be performed semiannually by Unit Maintenance personnel as listed and described in Table 4-1.

4-8. UNIT PMCS PROCEDURES.

- a. The item numbers of the tables indicate the sequence of the PMCS.
- b. If something doesn't work, troubleshoot it with the instructions in the manual or notify your supervisor.
- c. Always do your PMCS in the same order, so it becomes a habit. Once you've had some practice, you'll spot anything wrong in a hurry.
- d. If anything looks wrong and you can't fix it, write it down on your DA Form 2404. If you find something seriously wrong, report it to Direct Support Maintenance, as soon as possible.
- e. When you do your preventive maintenance, take along the tools you'll need to make all the checks. You'll always need a rag or two.

WARNING

Cleaning solvent, Federal Specification P-D-680, is toxic and flammable. Use solvent only in a well ventilated area. Avoid prolonged breathing of fumes. Keep solvent away from flames. Do not use in excessive amounts. Avoid skin contact.

- (1) **Keep it clean:** Dirt, grease, oil, and debris only get in the way and may cover up a serious problem. Clean as you work. Use cleaning solvents (Appendix E, item 1) on all metal surfaces. Use soap and water when you clean rubber or plastic materials.
- (2) **Bolts, nuts, and screws:** Check them all for obvious looseness, missing, bent, or broken condition. You can't try them all with a tool, of course, but look for chipped paint, bare metal or rust around bolt heads. If you find one you think is loose, tighten it, or report it to Direct Support Maintenance, if you can't tighten it.
- (3) **Welds:** Look for loose or chipped paint, rust, or gaps where parts are welded together. If you find a bad weld, report it to Direct Support Maintenance.

- (4) **Electric wires and connections:** Look for cracked or broken insulation, bare wires and loose or broken connectors. Tighten loose connectors and make sure the wires are in good shape.
- (5) **Hoses and fluid lines:** Look for wear, damage, and leaks, and make sure clamps and fittings are tight. Wet spots show leaks, of course, but a stain around a fitting or connector can mean a leak. If a leak comes from a loose fitting or connector, tighten it. If something is broken or worn out, report it to Direct Support Maintenance.

f. It is necessary for you to know how fluid leakage affects the status of the propelling unit. The following are definitions of the types/classes of leakage you need to know to be able to determine the status of the propelling unit. Learn; then be familiar with them and REMEMBER - WHEN IN DOUBT, NOTIFY YOUR SUPERVISOR.

Leakage Definitions for Unit PMCS

- CLASS I.** Seepage of fluid (as indicated by wetness or discoloration) not great enough to form drops.
- CLASS II.** Leakage of fluid great enough to form drops, but not enough to cause dripping from the item being checked or inspected.
- CLASS III.** Leakage of fluid great enough to form drops that fall from the item being checked or inspected.

Table 4-1. Unit Preventive Maintenance Checks and Services Semiannual Schedule

ITEM NO.	ITEM TO BE INSPECTED	PROCEDURE
1	Overspeed Governor	<p>Inspect overspeed governor for secure mounting and secure wiring. Operate throttle to increase engine speed. Ensure that the engine cannot run any faster than specified on data plate.</p> 
2	Exhaust Manifold	<p>Inspect exhaust manifold for secure mounting, loose, missing or damaged hardware. Inspect for cracks, holes, or exhaust gas leaks.</p> 

Table 4-1. Unit Preventive Maintenance Checks and Services Semiannual Schedule-Continued

ITEM NO.	ITEM TO BE INSPECTED	PROCEDURE
3	Fuel Injectors	Inspect the fuel injectors for damage (paragraph 4-29).
4	Rocker Arms, Valves, and Bridges, Assembly	Adjust the rocker arms, valves, and bridge (paragraph 4-39)
5	Power Unit Hydraulic Hose and Fittings	Inspect for frayed or leaking hoses and fittings (paragraph 4-55).
6	Upper Outdrive Hydraulic Hoses and Fittings	Inspect for frayed or leaking hoses and fittings (paragraph 4-55).

Section IV. UNIT TROUBLESHOOTING PROCEDURE

4-9. GENERAL.

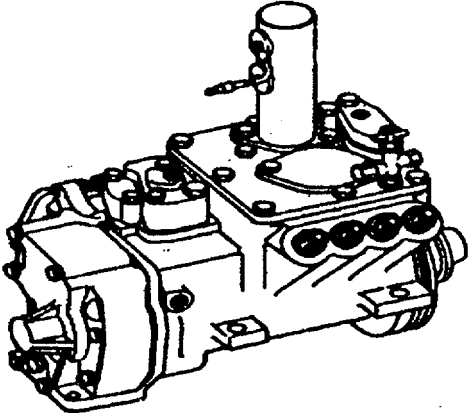
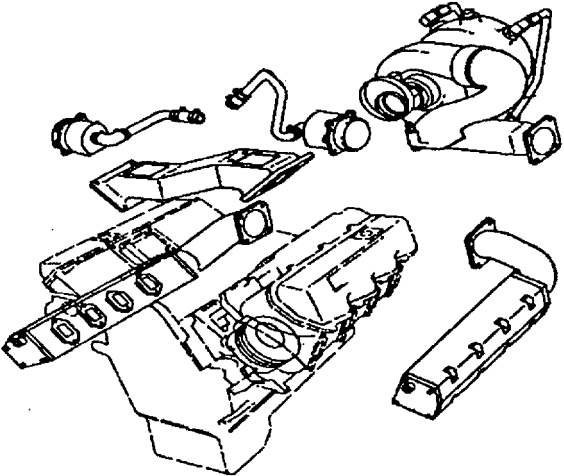
a. The table in this section lists the common malfunctions which you may find during operation or maintenance of the propelling unit or its components. You should perform the test or inspection and corrective maintenance in the order listed.

b. This manual cannot list all malfunctions that may occur, nor all tests or inspections and corrective actions. If a malfunction is not listed or it is not corrected by the listed correct actions, notify your supervisor.

Malfunction
Test or Inspection
Corrective Action

ENGINE

1. Engine Exhaust is Black or Grey.

Check for improperly timed or positioned injectors.
Check air cleaner for restrictions.

2. Engine Exhaust is Blue.

STEP 1. Remove air box covers one at a time with engine running at idle speed. Look for too much lubrication oil.

If oil is excessive, notify Direct Support Maintenance.

STEP 2. Perform a cylinder compression check on all cylinders. If compression is low in any or all cylinders, notify Direct Support Maintenance. If compression is normal, proceed to Step 3.

STEP 3. Check for worn or defective valve guides or seals. If valve guides or seals are worn or defective, notify Direct Support Maintenance. If valve guides or seals are not worn or defective, proceed to Step 4.

STEP 4. Remove air inlet housing and with engine running at 1/2 throttle and at idle, use a flashlight and inspect for oil leaking past blower seals. If oil is leaking past seals, replace blower.

3. Engine Exhaust is White.

Check for misfiring cylinders.
If cylinder is misfiring, notify Direct Support Maintenance.

Malfunction**Test or Inspection****Corrective Action**

4. Hard Starting.

STEP 1. Check for loose connections on all fuel lines and for cracked, broken or restricted fuel lines.

If fuel lines are cracked, broken or restricted, replace lines.

If fuel line connections are loose, tighten all lines.

If fuel line connections are tight and fuel lines are not cracked or broken, proceed to Step 2.

STEP 2. Check for dirty fuel filter.

If dirty, install new fuel filter.

STEP 3. Check for faulty fuel injector assembly and linkage.

If fuel injector is faulty, notify Direct Support Maintenance.

If linkage is defective, repair or replace linkage.

If fuel injector or linkage is not defective, proceed to Step 4.

STEP 4. Check for defective fuel pump or drive.

If fuel pump is defective, replace fuel pump.

If fuel pump drive is defective, replace drive.

If fuel pump or drive is not defective, proceed to Step 5.

STEP 5. Perform a cylinder compression check on all cylinders.

If compression is low in any or all cylinders, notify Direct Support Maintenance

If compression is normal in all cylinders, proceed to Step 6.

STEP 6. Check for worn or defective valve guides or seals.

If valve guides or seals are worn or defective, notify Direct Support Maintenance.

If valve guides or seals are not worn or defective, notify Direct Support Maintenance.

5. Uneven Running or Frequent Stalling

STEP 1. Check for low fuel pressure. Make sure there is fuel in fuel tank.

If outlet pressure of fuel is 10 psi or more, proceed to Step 2.

STEP 2. Check for defective fuel injectors and linkage or injector timing.

If fuel injector is defective, notify Direct Support Maintenance.

Malfunction**Test or Inspection****Corrective Action**

If fuel linkage is defective, replace linkage.

Check injector timing.

If fuel injector and linkage is not defective and injector timing is within limits, proceed to Step 3.

STEP 3. Perform a cylinder compression check on all cylinders.

If compression is low in any or all cylinders, notify Direct Support Maintenance.

If compression is normal in all cylinders, proceed to Step 4.

STEP 4. Check for worn or defective valve guides or seals.

If valve guides or seals are worn or defective, notify

Direct Support Maintenance.

6. Lack of Power.

STEP 1. Check for loose connections on all fuel lines and for cracked or restricted fuel lines.

If fuel lines are cracked, broken or restricted, replace lines.

If fuel line connections are loose, tighten.

If fuel line connections are tight and fuel lines are not cracked or broken, proceed to Step 2.

STEP 2. Check for bad quality fuel. Remove fuel from fuel tank.

Install a new fuel filter element. Put a good grade of clean fuel in the fuel tank.

If fuel quality is good, proceed to Step 3.

STEP 3. Check for low fuel pressure. The outlet pressure of the fuel transfer pump must be at least 28 psi at full load speed.

If fuel pressure is lower than the above pressure, install a new fuel filter element.

If fuel pressure is still low, check fuel transfer pump.

If fuel pressure is good, proceed to Step 4.

STEP 4. Check for leaks in air system. Check pressure in intake manifold. Look for restrictions in air cleaner.

If no leaks and restrictions are found, proceed to Step 5.

STEP 5. Check turbocharger for carbon deposits. Inspect and repair turbocharger as necessary. If no carbon is detected, proceed to Step 6.

Malfunction

Test or Inspection

Corrective Action

STEP 6. Check for faulty fuel injector assembly and linkage.
If fuel injector is faulty, notify Direct Support Maintenance.
If linkage is defective, replace linkage.
If fuel injector or linkage is not defective, proceed to Step 7.

STEP 7. Check for defective fuel pump or drive.
If fuel pump is defective, replace fuel pump.
If fuel pump drive is defective, replace drive.
If fuel pump or drive is not defective, proceed to Step 8.

STEP 8. Perform a compression check.
If compression is low in any or all cylinders, notify Direct Support Maintenance.
If compression is normal in all cylinders, proceed to Step 9.

STEP 9. Check for worn or defective valve guides or seals.
If valve guides or seals are worn or defective, notify Direct Support Maintenance.

7. Above Normal Coolant Temperature.

Step 1. Check cooling system.
If needed, add coolant to cooling system. Check for leaks.
If level is full, proceed to Step 2.

Step 2. Check for defective thermostat.
If thermostat will not open, replace thermostat.
If thermostat is not defective, proceed to Step 3.

Step 3. Check pressure relief valve for damage.
If damaged, replace.
If not damaged, proceed to Step 4.

Step 4. With coolant filler cap removed, check for combustion gases (bubbles) and/or engine oil in the coolant.
If combustion gases and/or engine oil are present, notify Direct Support Maintenance.
If combustion gases and/or engine oil are not present, proceed to Step 5.

STEP 5. Inspect for leaking, broken water pump.
If water pump is defective, replace water pump.

Malfunction

Test or Inspection

Corrective Action

8. Excessive Crankcase Pressure.

- STEP 1. Check cylinder compression.
If compression is low in any or all cylinders, notify Direct Support Maintenance.
If compression is within limits, proceed to Step 2.
- STEP 2. Check for restricted or damaged breather.
If breather is restricted or damaged, clean or repair breather as needed.
If breather is not damaged or restricted, proceed to Step 3.
- STEP 3. Check for damaged or restricted exhaust system.
If exhaust system is defective or restricted, replace defective parts.
If exhaust system is not damaged or restricted, proceed to Step 4.
- STEP 4. Check for defective gasket between turbo and block.
If gasket is defective, replace gasket.
If gasket is not defective, proceed to Step 5.
- STEP 5. Check for defective cylinder block end cover gasket.
If gasket is defective, notify Direct Support Maintenance.

9. Low Oil Pressure.

- STEP 1. Check for low oil level by using dipstick.
If oil level is low, add oil (Appendix E, item 2).
If oil level is normal, proceed to Step 2.
- STEP 2. Check for fuel leaks at injector nut seal ring which will cause dilution of the oil.
If seal ring is defective, notify Direct Support Maintenance.
If seal ring is not defective, proceed to Step 3.
- STEP 3. Remove oil cooler and check for restriction.
If oil cooler is restricted, clean and reinstall oil cooler.
If oil cooler is not restricted, proceed to Step 4.
- STEP 4. Check for defective oil cooler bypass valve.
If oil cooler bypass valve is defective, replace valve.
If oil cooler bypass valve is not defective, proceed to Step 5.

Malfunction

Test or Inspection

Corrective Action

STEP 5. Inspect for defective oil filter bypass valve.

If valve is defective, replace valve.

If valve is not defective, proceed to Step 6.

STEP 6. Check for defective sending unit.

If sending unit is defective, replace sending unit.

If sending unit is not defective, proceed to Step 7.

STEP 7. Check for defective gauge.

If gauge is defective, replace gauge.

If gauge is not defective, proceed to Step 8.

STEP 8. Check for obstructed gauge line and orifices.

If gauge line or orifices are obstructed, replace line and orifices as required.

If gauge line or orifices are not obstructed, proceed to Step 9.

STEP 9. Check for defective oil pump.

If oil pump is defective, replace oil pump.

If oil pump is not defective, proceed to Step 10.

STEP 10. Steam clean engine and then operate engine at idle speed.

If oil leaks are visible, repair or replace defective parts.

Section V. UNIT MAINTENANCE PROCEDURES

4-10. REPAIR PROPELLING UNIT

This Task Covers: a. Inspect b. Service c. Adjust d. Repair

INITIAL SETUP

Tools Required

Tool Kit, General
Mechanics (Appendix B,
Item 1)

Equipment Condition

Engine Shutdown (para 2-11).
Battery Disconnected (para 4-58).

Materials/Parts Required

Cotton Rags (Appendix E,
Item 3)

Personnel Required

1 Person

INSPECT

1. Inspect for spills and debris.
2. Inspect for damage.
3. For corrective maintenance of individual components, notify your supervisor.

SERVICE Refer to LO5-2010-205-12 for lubrication intervals and service procedures.

ADJUST Adjustments are limited to adjustments of individual components. Refer to appropriate paragraph for maintenance procedures.

REPAIR Repairs are limited to replacement of individual components. Refer to appropriate paragraph for maintaining procedures.

4-11. FRAMEWORK ASSEMBLY

This Task Covers: a. Inspect

INITIAL SETUP

Tools Required

None

Materials/Parts Required

Cotton Rags (Appendix E,
Item 3)

Equipment Conditions

Engine Shutdown (para 2-11).

Personnel Required

1 person

INSPECT (Figure 4-1.)

1. Inspect for loose bolts.
2. Inspect for cracked welds.
3. Inspect for signs of rust and chipping paint.

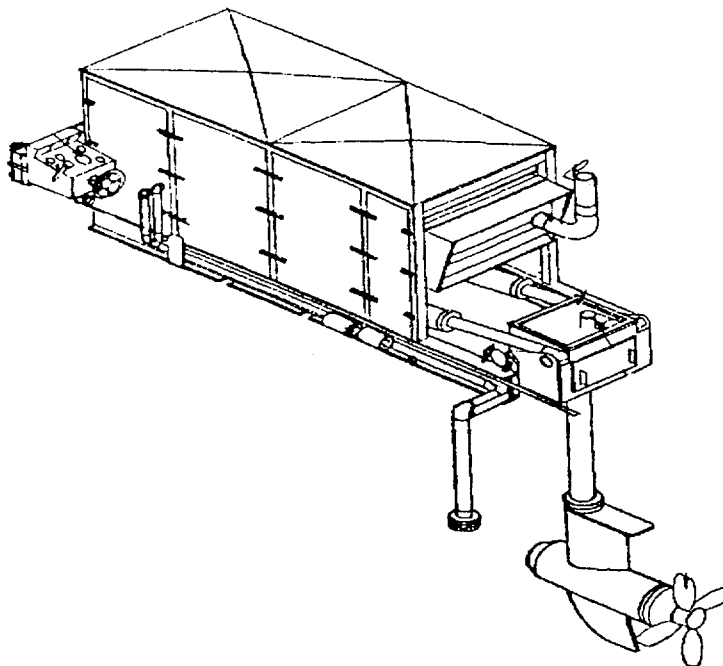

Figure 4-1. Propelling Unit

4-12. REPAIR ENGINE ASSEMBLY

This Task Covers: a. Inspect b. Service c. Repair

INITIAL SETUP

Tools Required

Tool Kit, General
Mechanics (Appendix B,
Item 1)

Equipment Conditions

Engine Shutdown (para 2-11).
Battery Disconnected (para 4-58).

Materials/Parts Required

Cotton Rags (Appendix E,
Item 3)

Personnel Required

1 person

INSPECT (Figure 4-2.)

1. Inspect for leaks. If leaking is observed, notify supervisor.
2. Inspect for loose bolts, worn belts and debris.

SERVICE

NOTE

As the air cleaner (2) element becomes plugged, the difference of air pressure between the inlet side (dirty side) will increase. The primary element can be cleaned up to six times before replacement. The element, when cleaned, should be thoroughly checked for rips or tears in the filter material.

1. Service air cleaner when indicator (1) turns red.
2. Clean air cleaner with water.

WARNING

To prevent burns and to prevent damage to the engine, do not add coolant to an overheated engine. Allow the engine to cool first.

WARNING

Use caution when removing the filler cap while the engine is still hot.

3. Check levels of coolant in expansion tank. Fill within 1" of the top.
4. Check specific gravity of antifreeze solution frequently in cold weather to ensure adequate protection.
5. Check coolant level with engine stopped and cold. Remove filler cap (3) slowly to relieve pressure. Some loose debris or scale may be visible; a small amount is normal. Wipe off filler cap and filler neck.
6. Maintain engine oil level between marks on gauge (4).

REPAIR Repair is limited to replacement or repair of individual components.

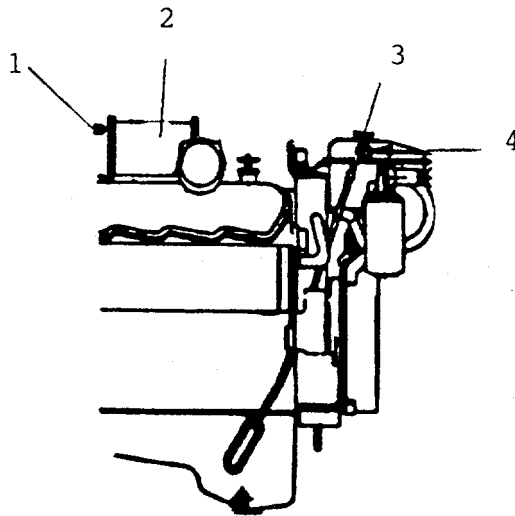

Figure 4-2. Engine Assembly

4-13. REPLACE COOLER ASSEMBLY (OIL)

This Task Covers: a. Inspect b. Replacement

INITIAL SETUP

Tools Required

Tool Kit, General
Mechanics (Appendix B,
Item 1)

Equipment Required

Engine Shutdown (para 2-11).
Battery Disconnected (para 4-58).

Materials/Parts Required

Cotton Rags (Appendix E,
Item 3)
Permanent Antifreeze
(Appendix E, Item 4)
Packing, Preformed P/N 2M9780

Personnel Required

1 person

INSPECT (Figure 4-3.) Look for restrictions in oil passages of oil cooler. If oil cooler has a restriction, oil cooler bypass valve in oil filter base will open. This will cause flow of oil to go around oil cooler. Oil temperature will be higher than normal when engine is running. Oil pressure of the engine will become low if oil cooler has a restriction.

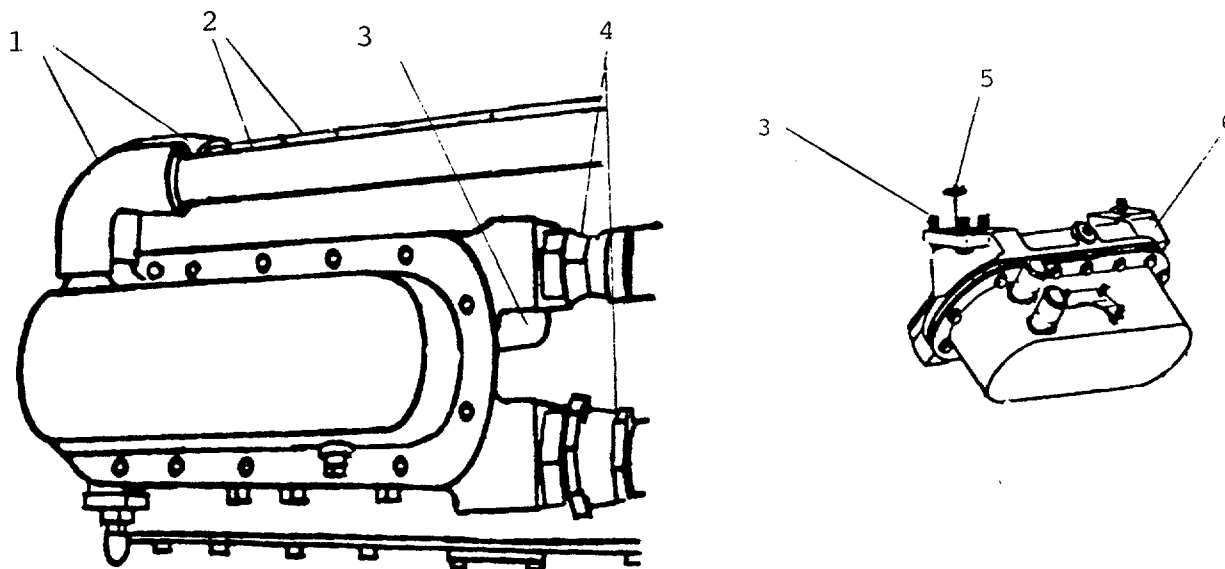

Figure 4-3. Cooler Assembly (Oil)

REPLACEMENT

1. Loosen hose clamps (1).
2. Remove hoses (2).
3. Remove engine lube oil hoses (4).
4. Remove screws and washers (3).

NOTE

O-Ring is to be discarded and new O-Ring installed.

5. Remove assembly (6).
6. Remove O-Ring (5).
7. Install new O-Ring (5).
8. Install assembly (6).
9. Install washers and screws (3).
10. Install engine lube oil hoses (4).
11. Install cooling water hoses (2).
12. Tighten hose clamps (1).
13. Fill the cooling system with coolant (a fifty-fifty mixture of clean, fresh water and permanent anti-freeze).
14. Fill engine lube oil system (LO5-2010-205-12).
15. Start engine and check for leaks.

4-14. OIL PUMP ASSEMBLY

This Task Covers: a. Inspect

INITIAL SETUPTools Required

None

Equipment Conditions

Engine Running.

Materials/Parts Required

Cotton Rags (Appendix E,
Item 3)

Personnel Required

1 person

INSPECT

1. Inspect for low engine oil pressure.
2. Inspect for oil leaks.
3. If low pressure is indicated, contact your supervisor.

4-15. TURBOCHARGER ASSEMBLY

This Task Covers: a. Inspect

INITIAL SETUP

Tools Required

None

Equipment Conditions

Engine Shutdown (para 2-11).
Battery Disconnected (para 4-58).

Materials/Parts Required

None

Personnel Required

1 person

INSPECT (Figure 4-4.)

NOTE

The bearings for the Turbocharger use engine oil for lubrication. The oil comes in through the lubrication inlet passage (1) and goes through passages in the center section for lubrication of the bearings. Oil from the turbocharger goes out through the lubrication outlet passage (2) in the bottom of the center section and goes back to the engine lubrication system.

1. Inspect for leaks.

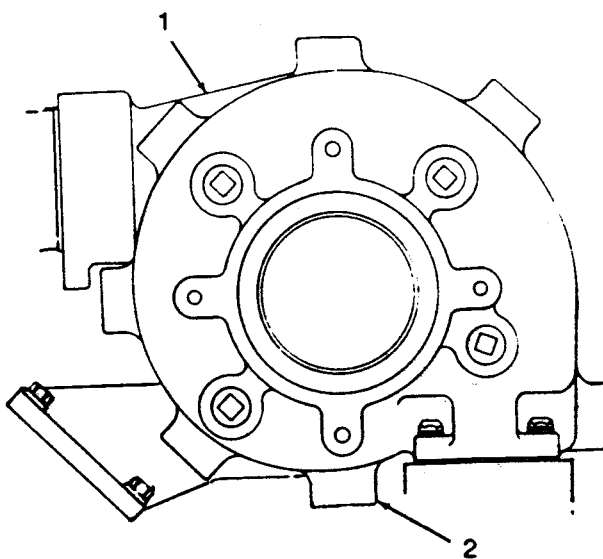

Figure 4-4. Turbocharger Assembly.

4-16. MANIFOLD ASSEMBLY

This Task Covers: a. Inspect

INITIAL SETUP

Tools Required

Tool Kit, General Mechanics
(Appendix B, Item 1)

Materials/Parts Required

Cotton Rags (Appendix E,
Item 3)

Equipment Conditions

Engine Shutdown (para 2-11).
Battery Disconnected (para 4-58).

Personnel Required

1 person

INSPECT (Figure 4-5.)

1. Inspect for loose bolts (1) on exhaust manifold (2).
2. Inspect for leaks in gaskets.

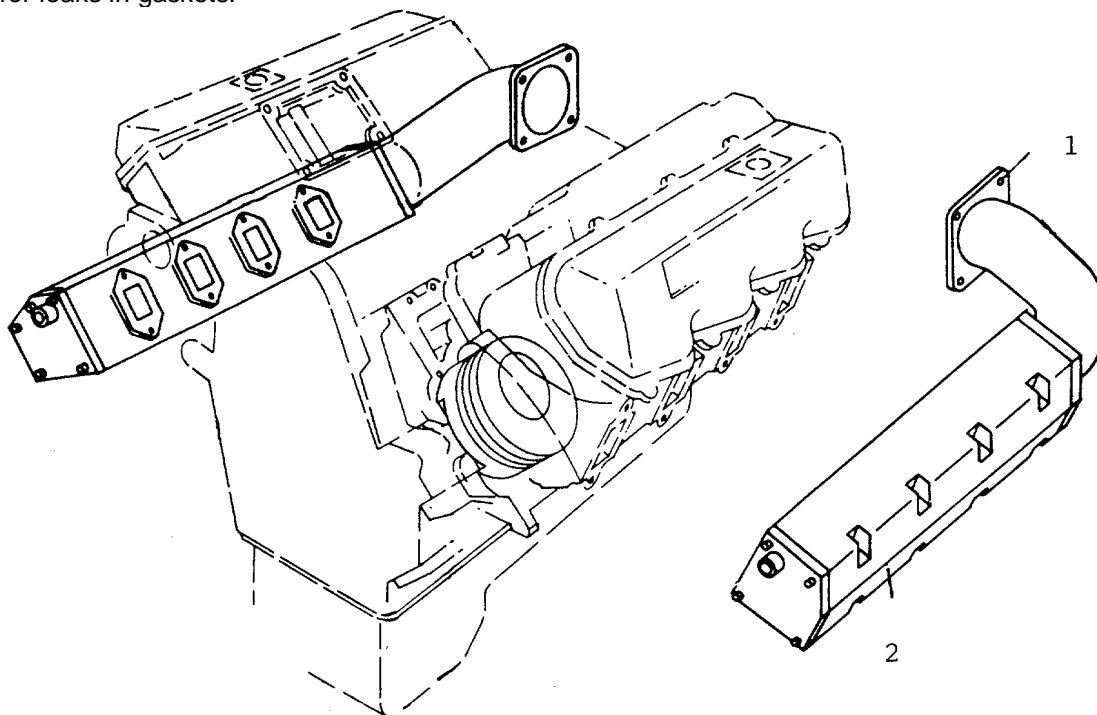

Figure 4-5. Manifold Assembly

4-17. REPAIR/REPLACE EXPANSION TANK ASSEMBLY

This Task Covers: a. Inspect b. Repair c. Replacement

INITIAL SETUP

Tools Required

Tool Kit, General
Mechanics (Appendix B,
Item 1)
Nylon Strap

Equipment Conditions

Engine Shutdown (para 2-11).
Battery Disconnected (para 4-58).

Materials/Parts Required

Cotton Rags (Appendix E,
Item 3)
Permanent Antifreeze
(Appendix E, Item 4)

Personnel Required

2 persons

INSPECT (Figure 4-6.)

1. Inspect for loose bolts (3).
2. Inspect for leaks around cap (2) and gaskets (1) on tank (4).

REPAIR Repair is limited to the replacement of defective components.

REPLACEMENT

1. Remove screws (5) to remove front cover (6).
2. Loosen hose clamps (7).
3. Remove hoses (8, 9, and 10) from heat exchanger.
4. Remove fuel lines (11) from junction block (12).
5. Remove bolts (13) and junction block (12) from engine.
6. Remove hoses (14) and (15) from. heat exchanger.

NOTE

The weight of the unit is approximately 85 lb.

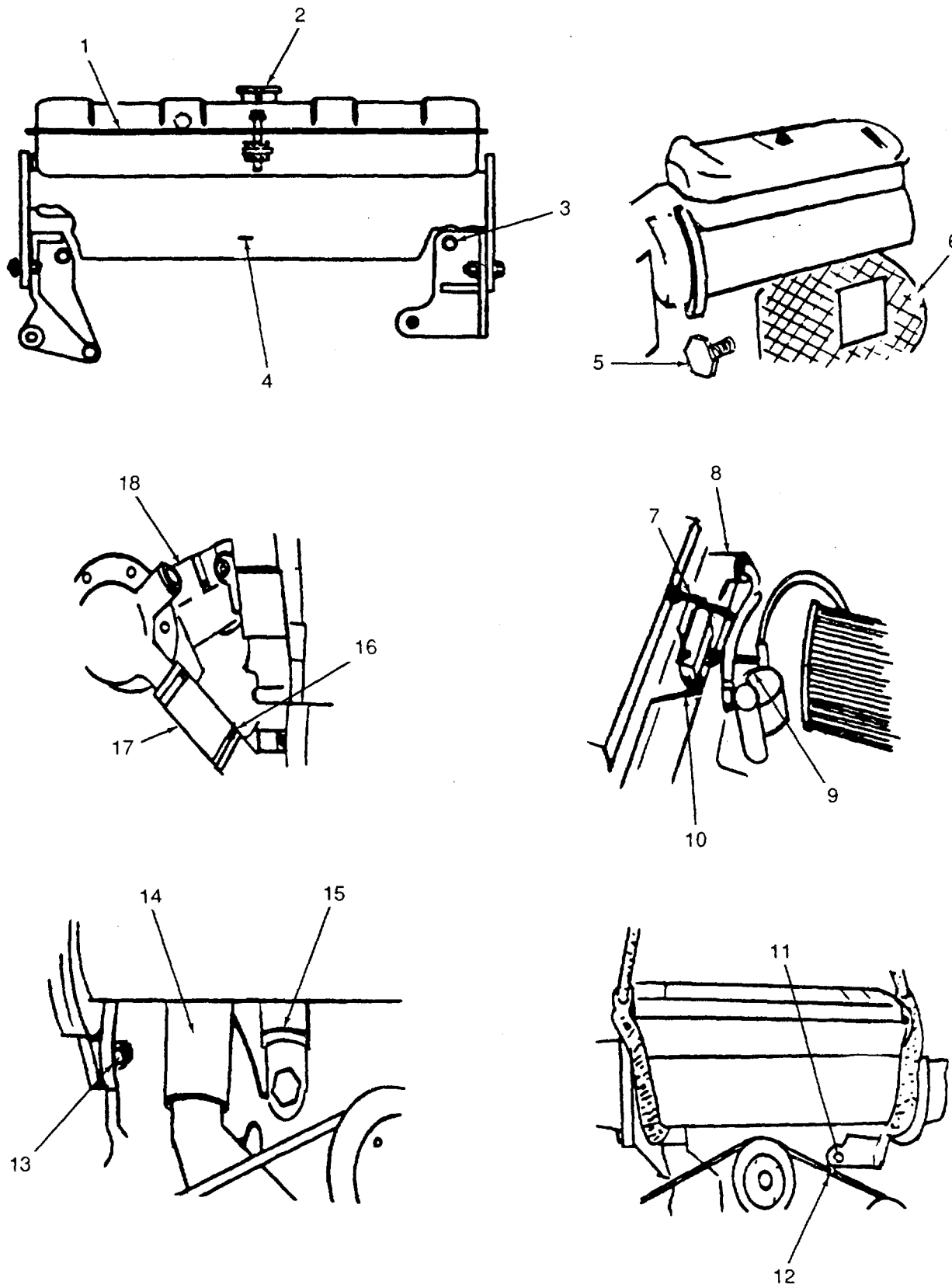

Figure 4-6. Expansion Tank Assembly

7. Remove bolt and nut (16) from heat exchanger.
8. Remove bolt and nut (17) and holding bracket (18) from timing gear cover (6).
9. Remove expansion tank and heat exchanger (4) as a unit.
10. Install expansion tank and heat exchanger.
11. Install holding bracket (18) and bolt and nut (17) to timing gear cover (6).
12. Install bolt and nut (16) to heat exchanger.
13. Install hoses (14) and (15) to heat exchanger.
14. Install bolts (13) and junction block (12) to engine.
15. Install fuel lines (11) to junction block.
16. Install hoses (8, 9, and 10) to heat exchanger.
17. Tighten hose clamps.
18. Install screws (5) to front cover (6).
19. Add coolant (a fifty-fifty mixture of clean, fresh water and permanent anti-freeze) to expansion tank.

4-18. REPLACE FUEL PRIME PUMP ASSEMBLY

This Task Covers: a. Inspect b. Replacement

INITIAL SETUP

Tools Required

Tool Kit, General
Mechanics (Appendix B,
Item 1)

Equipment Conditions

Engine Shutdown (para 2-11).
Battery Disconnected (para 4-58).

Materials/Parts Required

Cotton Rags (Appendix E,
Item 3)
Gasket sealant (Appendix E,
Item 6)
Gasket P/N 1P0436

Personnel Required

1 person

INSPECT

CAUTION

Before any service work is done on the fuel system, the outer surface of the fuel prime pump housing must be cleaned.

1. Inspect for leaks around gaskets (4) on pump (1).
2. Check for loose bolts (2).

REPLACEMENT (Figure 4-7.)

1. Remove fuel line (3).
2. Remove screws (2) and washers (5).
3. Remove pump assembly (1) from fuel filter housing (6).
4. Remove gasket (4) from housing.
5. Install new gasket.
6. Install pump assembly.
7. Install screws and washers.
8. Install new fuel filter cartridge (7).

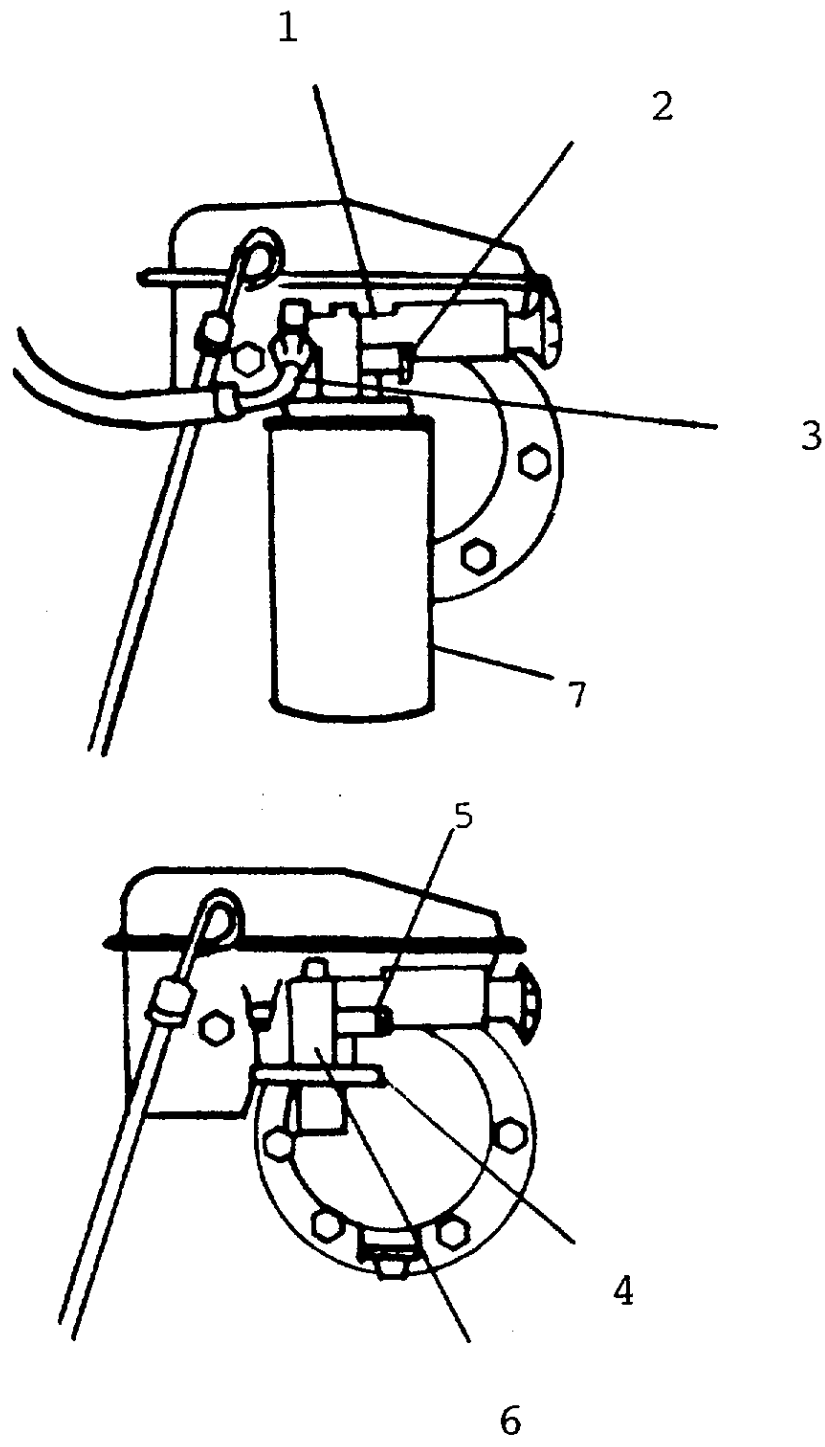

Figure 4-7. Fuel Prime Pump Assembly.

4-19. OIL PAN ASSEMBLY

This Task Covers: a. Inspect

INITIAL SETUP

Tools Required

Tool Kit, General
Mechanics (Appendix B,
Item 1)

Equipment Conditions

Engine Shutdown (para 2-11).
Battery Disconnected (para 4-58).

Materials/Parts Required

Cotton Rags (Appendix E,
Item 3)

Personnel Required

1 person

INSPECT (Figure 4-8.)

1. Inspect for loose screws (1) and drain plug (3) on pan (2).
2. Inspect for oil leaks around pan (2).

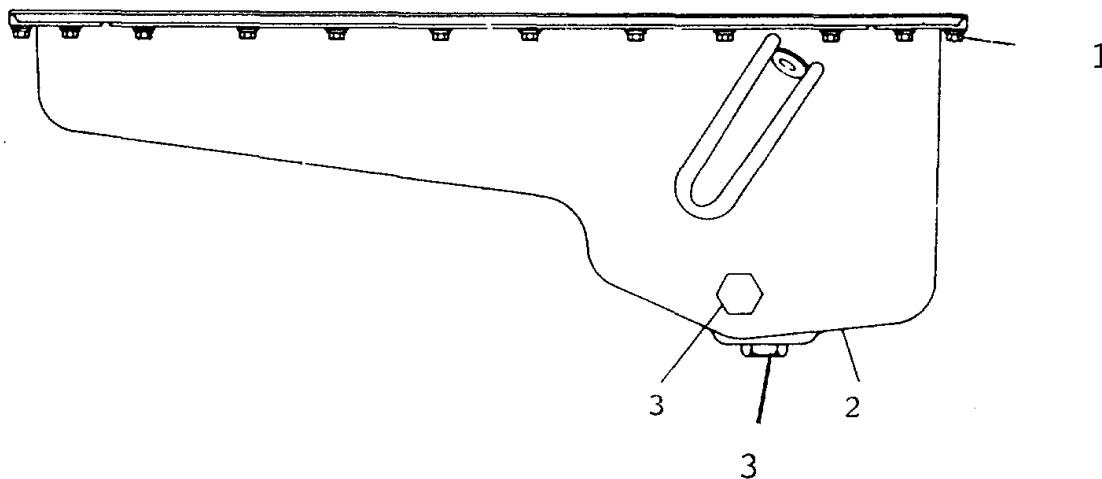

Figure 4-8. Oil Pan Assembly.

4-20. REPLACE OIL LEVEL GAUGE ASSEMBLY

This Task Covers: a. Inspect b. Replacement

INITIAL SETUP**Tools Required**

Tool Kit, General
Mechanics (Appendix B,
Item 1)

Equipment Conditions

Engine Shutdown (para 2-11).
Battery Disconnected (para 4-58).

Materials/Parts Required

Cotton Rags (Appendix E,
Item 3)
Oil Level Gage P/N 4N4542

Personnel Required

1 person

INSPECT (Figure 4-9.)

1. Check tightness of bolts (2), (4), and nut (6).

REPLACEMENT

1. Loosen nut (6).
2. Remove tube (7) and gauge (1).
3. Install tube.
4. Tighten nut (6).
5. Install and tighten bolt (3), washer (5), and nut (2).
6. Insert gauge (1) into tube (7).

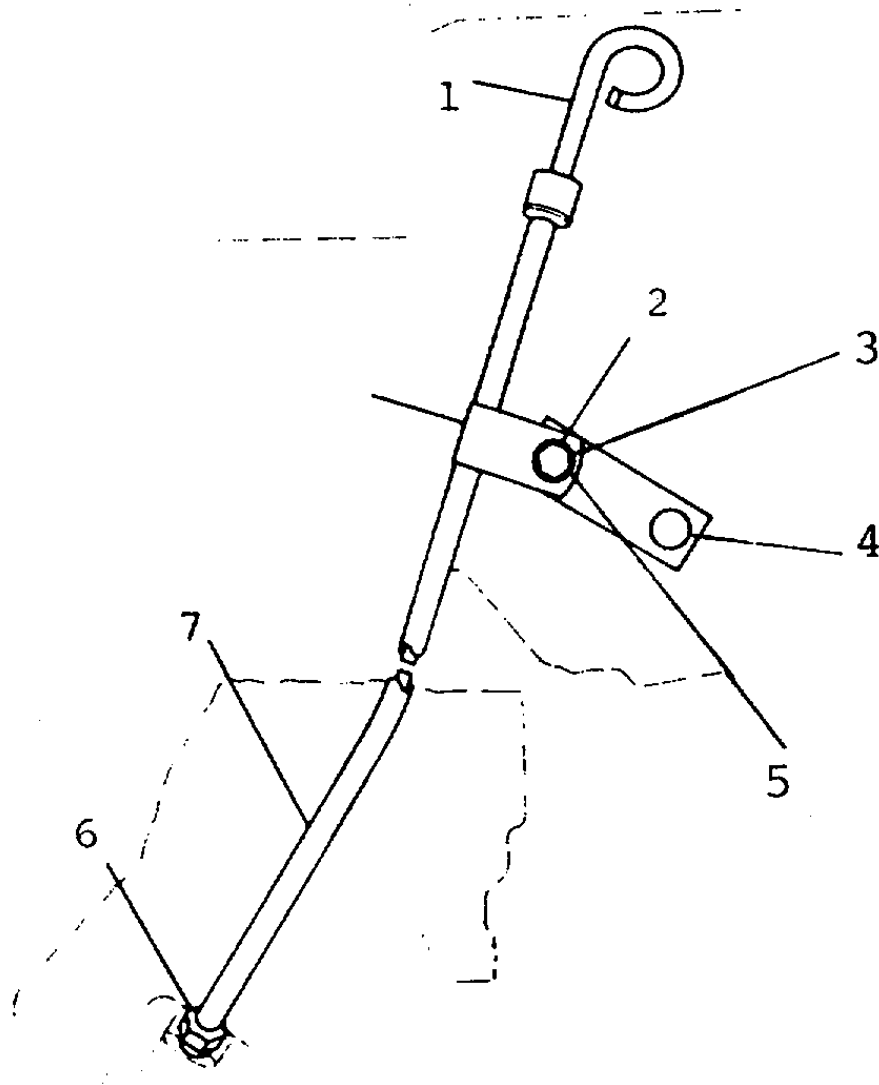

Figure 4-9. Oil Level Gauge Assembly.

4-21. GOVERNOR CONTROL ASSEMBLY

This Task Covers: a. Inspect

INITIAL SETUPTools Required

Tool Kit, General Mechanics
(Appendix B, Item 1)

Materials/Parts Required

Cotton Rags (Appendix E,
Item 3)

Equipment Conditions

Engine Shutdown (para 2-11).
Battery Disconnected (para 4-58).

Personnel Required

1 person

INSPECT (Figure 4-10.)

1. Inspect tightness of bolt (2) on handle (1).
2. Inspect for worn parts.

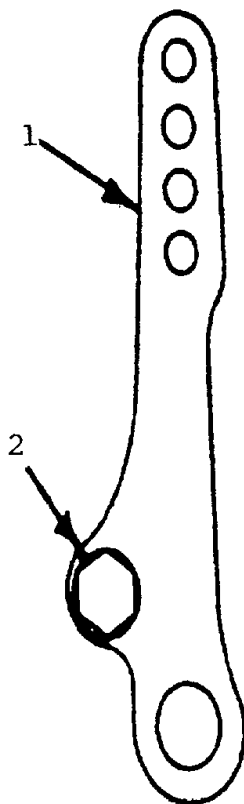

Figure 4-10. Governor Control Assembly

4-22. FLYWHEEL HOUSING ASSEMBLY

This Task Covers: a. Inspect

INITIAL SETUPTools Required

None

Materials/Parts Required

Cotton Rags (Appendix E,
Item 3)

Equipment Conditions

Engine Shutdown (para 2-11).
Battery Disconnected (para 4-58).

Personnel Required

1 person

INSPECT (Figure 4-11.)

1. Inspect for oil leaks around gasket (1).
2. Inspect for cracks in housing (2).

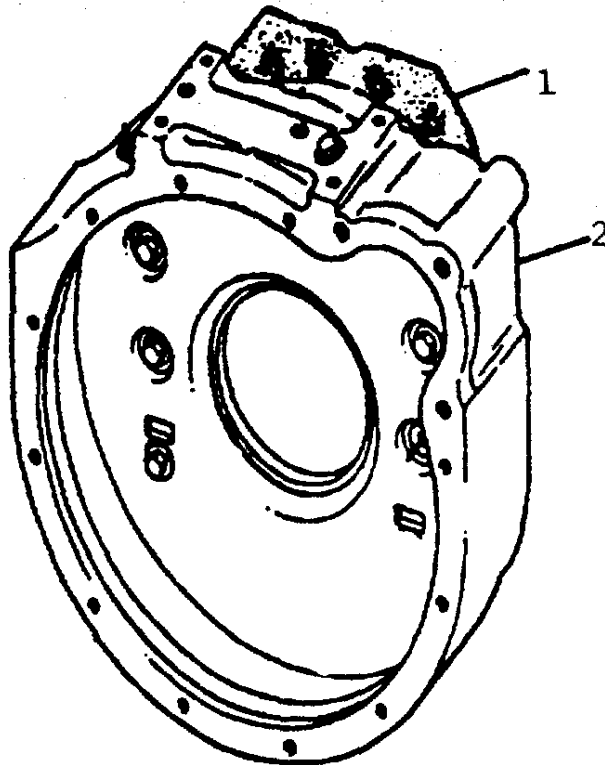

Figure 4-11. Flywheel Housing Assembly
4-31

4-23. REPLACE FUEL FILTER ASSEMBLY

This Task Covers: a. Inspect b. Service c. Replacement

INITIAL SETUP**Tools Required**

Tool Kit, General Mechanics
(Appendix B, Item 1)

Equipment Conditions

Engine Shutdown (para 2-11).
Battery Disconnected (para 4-58).

Materials/Parts Required

Cotton Rags (Appendix E,
Item 3)
Gasket Sealant (Appendix E,
Item 6)
Filter Element P/N 1P2299
Gasket P/N 1P0436

Personnel Required

1 person

INSPECT (Figure 4-12.)

1. Inspect tightness of filter element (2).
2. Inspect filter body (1) for damage.
3. Inspect for leaks.

SERVICE

1. Remove filter element (2).
2. Replace with new element.

REPLACEMENT

1. Remove fuel filter prime pump assembly (para. 4-18).

NOTE

If cartridge is to be replaced, proceed to steps 2 and 9.

2. Remove fuel filter (2) from fuel filter base (1).
3. Remove screws and washers (3).

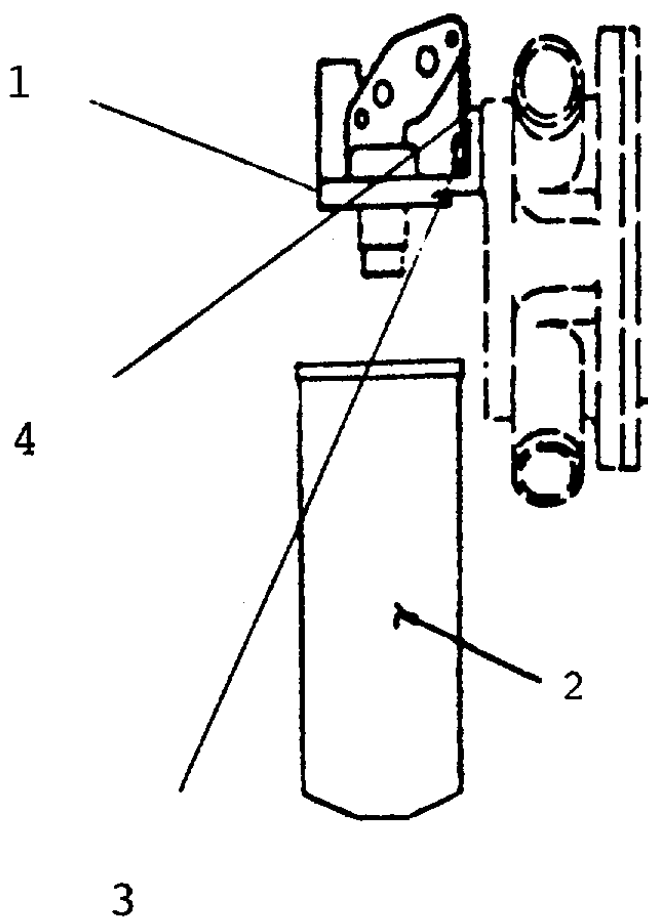

Figure 4-12. Fuel Filter Assembly

4. Remove fuel filter base (1).
5. Remove gasket (4).
6. Install new gasket (4).
7. Install fuel filter base (1).
8. Install screws and washers (3).
9. Install fuel filter (2).
10. Install fuel filter prime pump assembly (para. 4-18).

4-24. REPLACE SEAWATER EXCHANGER ASSEMBLY

This Task Covers: a. Inspect b. Replacement

INITIAL SETUP

Tools Required

Tool Kit, General Mechanics
(Appendix B, Item 1)

Equipment Conditions

Engine Shutdown (para 2-11).
Battery Disconnected (para 4-58).

Materials/Parts Required

Cotton Rags (Appendix E,
Item 3)

Personnel Required

2 persons

INSPECT For inspection procedures, refer to para 4-17.

REPLACEMENT For replacement procedures, refer to para 4-17.

4-25. REPLACE WATER LINES

This Task Covers: a. Inspect b. Replacement

INITIAL SETUPTools Required

Tool Kit, General Mechanical
(Appendix B, Item 1)

Materials/Parts Required

Cotton Rags (Appendix E,
Item 3)

Equipment Conditions

Engine Shutdown (para 2-11).
Battery Disconnected (para 4-58).

Personnel Required

1 person

INSPECT (Figure 4-13.)

1. Inspect for loose hose clamps (4) typical.
2. Inspect for loose bolts (2) typical.
3. Inspect for loose pipe fittings (3) typical.
4. Inspect for leaks at all connections.

REPLACEMENT

1. Loosen water line fittings (1) typical.
2. Loosen bolt (2) on clamp (5).
3. Remove damaged water line (6) typical.
4. Install water line.
5. Tighten water line fitting.
6. Tighten bolt (2) on clamp (5) if loosened.

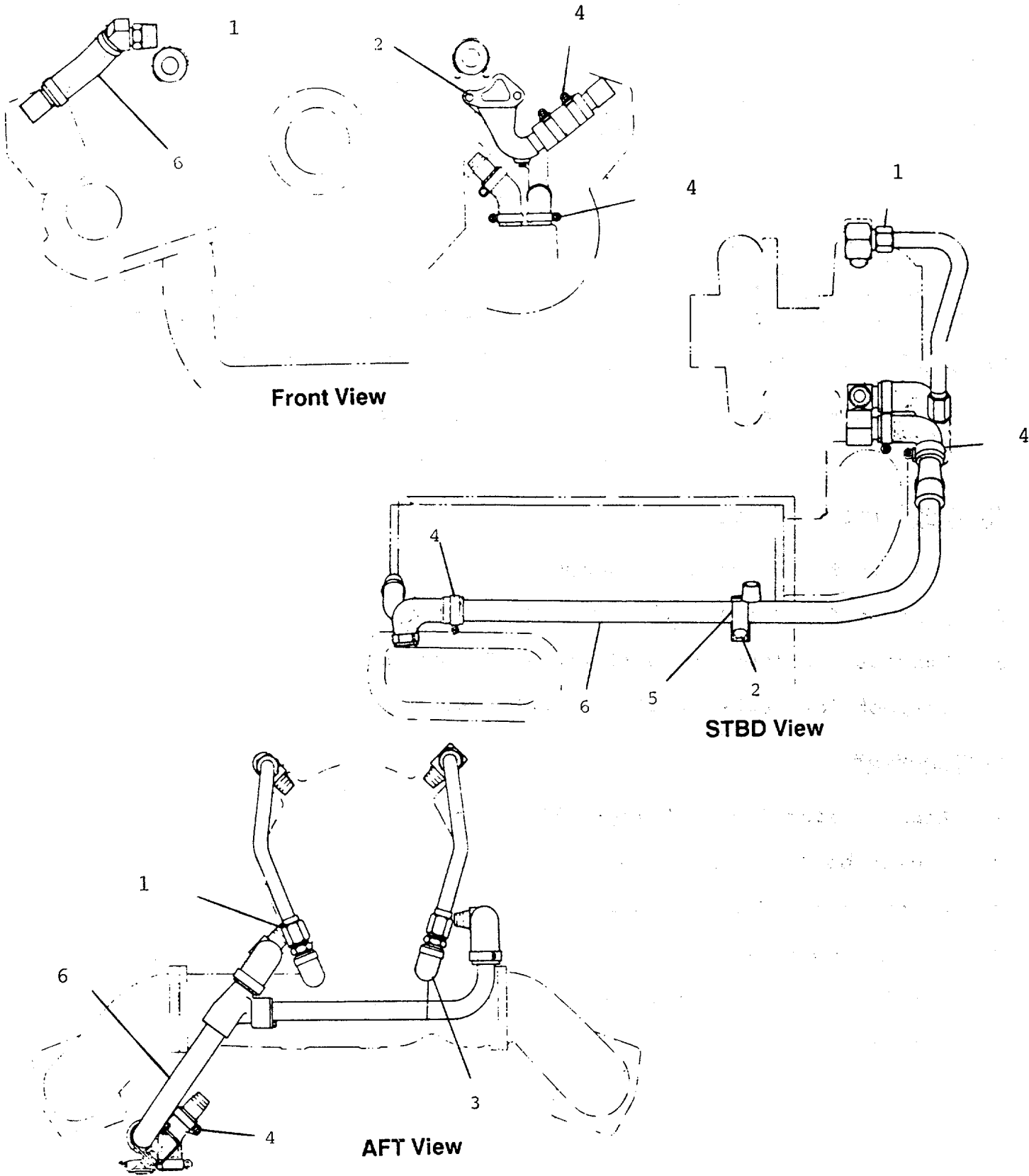

Figure 4-13. Water Lines.

4-26. PAIR/REPLACE CONNECTION ASSEMBLY

This Task Covers: a. Inspect b. Repair c. Replacement

INITIAL SETUP**Tools Required**

Tool Kit, General Mechanics
(Appendix B, Item 1)

Equipment Conditions

Engine Shutdown (para 2-11).
Battery Disconnected (para 4-58).

Materials/Parts Required

Cotton Rags (Appendix E,
Item 3)

Personnel Required

1 person

INSPECT (Figure 4-14.)

1. Inspect for loose bolts (2) typical.
2. Inspect for loose hose clamps (9) typical.
3. Inspect for loose pipe fittings (1) typical.
4. Inspect for leaks.

REPAIR Repair is limited to the replacement of defective parts.

REPLACEMENT

1. Loosen retaining clamp (8) if installed.
2. Loosen fitting or clamp.

NOTE

If pipe tee (4) is to be removed and replaced, proceed to steps 4 through 9.

3. Remove damaged line.
4. Loosen and remove lines (3, 5, and 7).
5. Loosen and remove nut and washer (6).
6. Remove pipe tee (4).

7. Install pipe tee.
8. Replace nut and washer (6).
9. Assemble and tighten fittings on lines (3, 5, and 7).

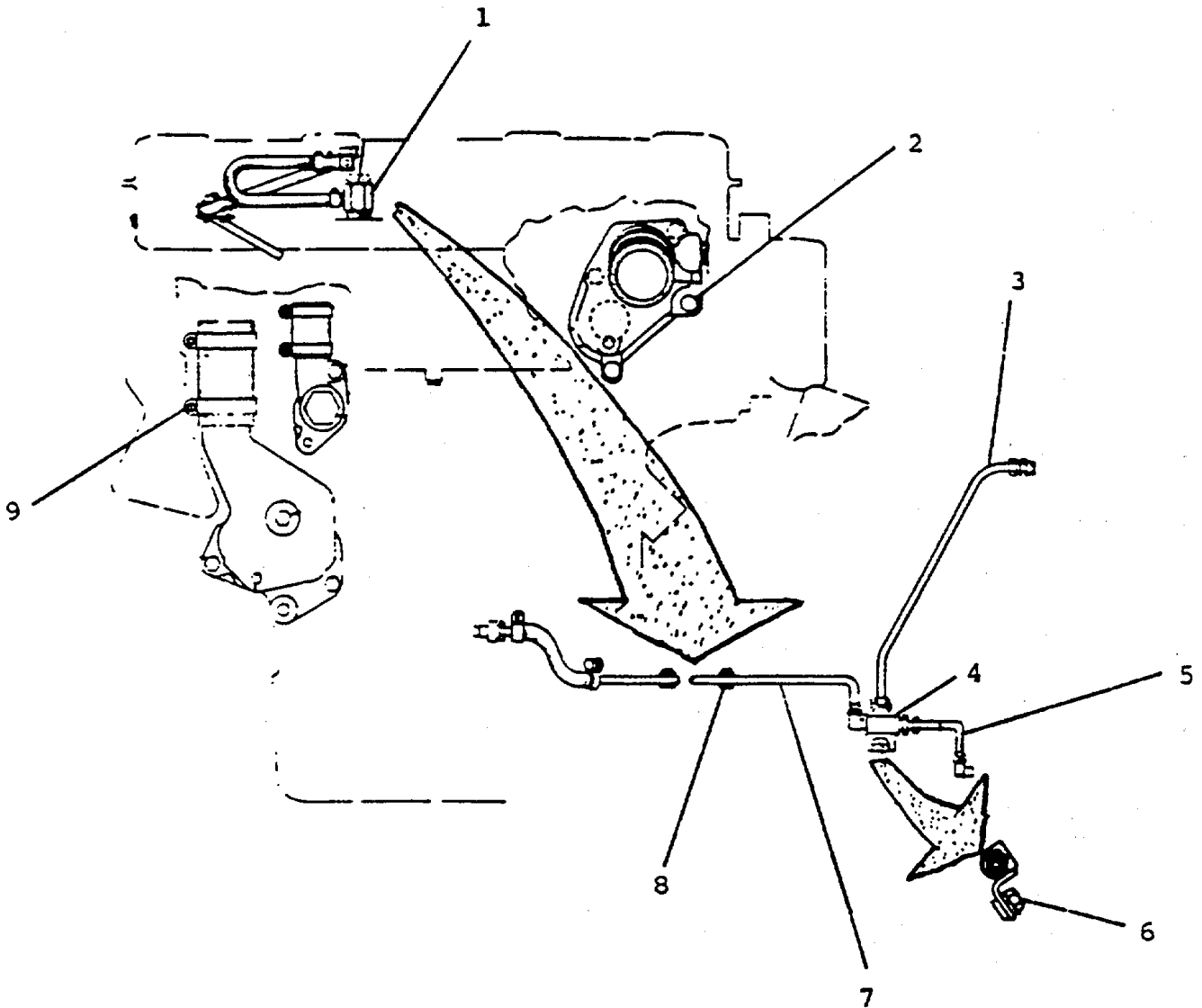

Figure 4-14. Connection Assembly.

4-27. REPAIR/REPLACE AUXILIARY LINES

This Task Covers: a. Inspect b. Repair c. Replacement

INITIAL SETUP

Tools Required

Tool Kit, General Mechanics
(Appendix B, Item 1)

Materials/Parts Required

Cotton Rags (Appendix E,
Item 3)
Tube P/N 8N5099
Hose P/N 6N383

Equipment Conditions

Engine Shutdown (para 2-11).
Battery Disconnected (para 4-58).

Personnel Required

1 person

INSPECT (Figure 4-15.)

1. Inspect tubing and hose fittings for looseness.
2. Inspect for leaks.

REPAIR Repair is limited to the replacement of defective parts.

REPLACEMENT

1. Loosen tubing fitting (1) on damaged line.
2. Remove damaged line.
3. Replace with new line.
4. Tighten tubing fittings.

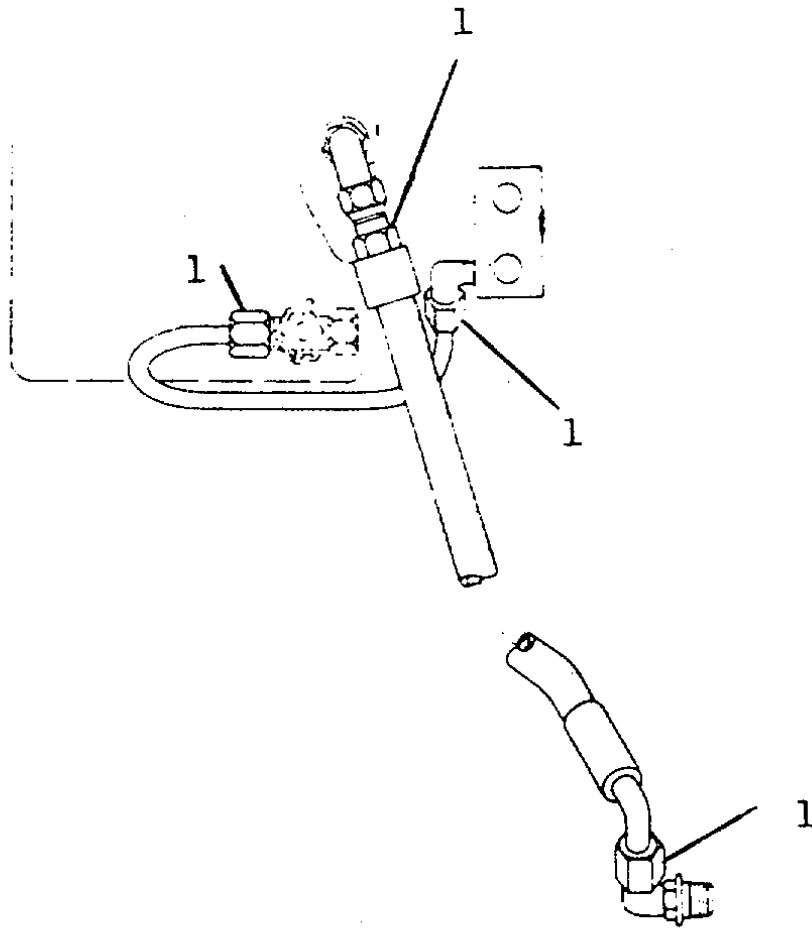

Figure 4-15. Auxiliary Lines.

4-28. GOVERNOR PUMP ASSEMBLY

This Task Covers: a. Inspect

INITIAL SETUPTools Required

Tool Kit, General Mechanics
(Appendix B, Item 1)

Materials/Parts Required

Cotton Rags (Appendix E,
Item 3)

Equipment Condition

Engine Shutdown (para 2-11).
Battery Disconnected (para 4-58).

Personnel Required

1 person

INSPECT (Figure 4-16.)

1. Clean all connections to pump (1).
2. Inspect for loose bolts (2).
3. Inspect for leaks.

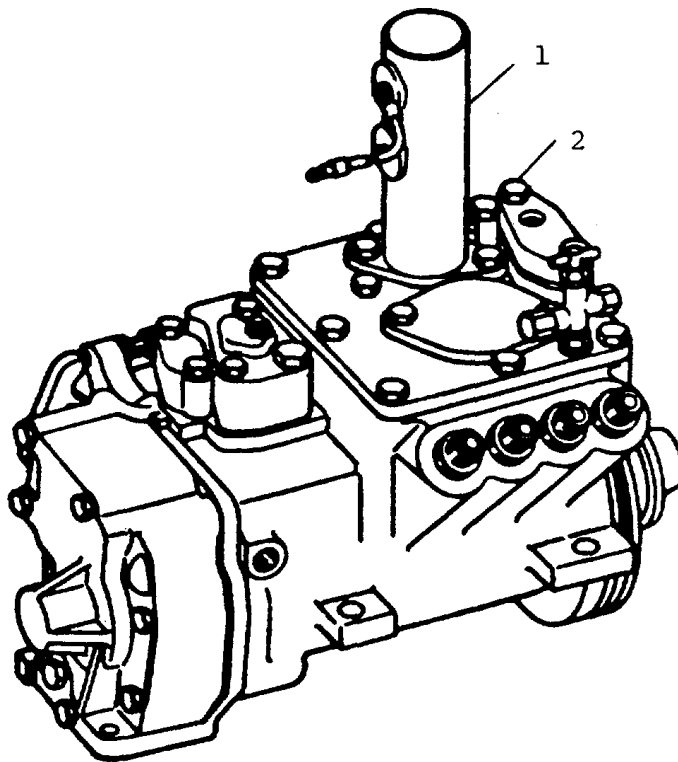

Figure 4-16. Governor Pump Assembly

4-29. REPLACE FUEL INJECTION LINES ASSEMBLY

This Task Covers: a. Inspect b. Replacement

INITIAL SETUP**Tools Required**

Tool Kit, General Mechanics
(Appendix B, Item 1)

Materials/Parts Required

Cotton Rags (Appendix E,
Item 3)

Equipment Conditions

Engine Shutdown (para 2-11).
Battery Disconnected (para 4-58).

Personnel Required

1 person

INSPECT (Figure 4-17.)

1. Inspect for loose connections.
2. Inspect for cracked lines.

REPLACEMENT**CAUTION**

If new fuel lines are used for replacement, remove identification tags from lines. Tags cause wear on fuel injection system lines.

CAUTION

Put protective covers on all lines and pumps to keep dirt out of fuel system.

1. Loosen fittings (1) and (4).
2. Remove vent line (5).
3. Loosen clamps (7).
4. Remove hose (6).
5. Loosen and remove bolt (2).

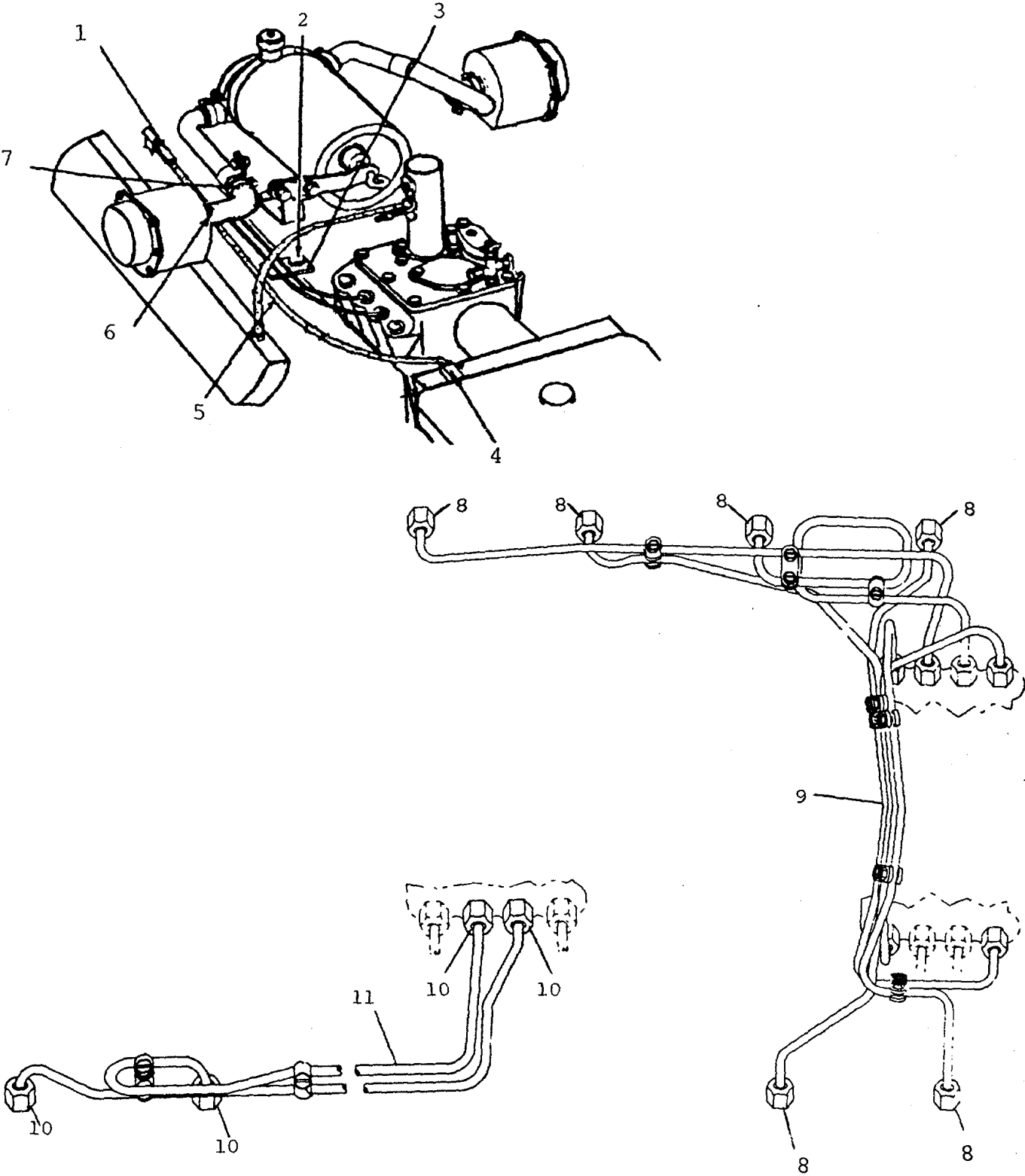

Figure 4-17. Fuel Injection Lines Assembly.

6. Remove Bracket (3).

CAUTION

Thoroughly clean around each fuel line connection before fuel lines are disconnected.

NOTE

Put tags on fuel lines to identify their location.

7. Loosen connections (8) typical.
8. Remove line assembly (9).
9. Loosen connections (10) typical.
10. Remove line assembly (11).

NOTE

All fuel injection line nuts (8) and (10) will be tightened to a torque of 30 lb-ft.

11. Assemble line (11) onto cylinders and fuel injection pump.
12. Tighten nuts (10) typical.
13. Assemble line (9) onto cylinders and fuel injection pump.
14. Tighten nuts (8) typical.
15. Install bracket (3).
16. Install and tighten bolt (2).
17. Install hose (6).

NOTE

The hose clamp connection (7) will be tightened to a torque of 20 lb-ft.

18. Install hose clamp (7) and tighten.
19. Install vent line (5).
20. Tighten fittings (1) and (4).

4-30. REPLACE MECHANICAL COVER ASSEMBLY

This Task Covers: a. Inspect b. Replacement

INITIAL SETUPTools Required

Tool Kit, General Mechanics
(Appendix B, Item 1)
PCV lines removed (para 4-33).

Equipment Conditions

Engine Shutdown (para 2-11).
Battery disconnected (para 4-58).

Materials/Parts Required

Cotton Rags (Appendix E,
Item 3)
Gasket P/N 9L8020

Personnel Required

1 person

INSPECT (Figure 4-18.)

1. Inspect cover (3) for damage.
2. Inspect for loose bolts (2).

REPLACEMENT

1. Loosen hose clamp (1).
2. Remove hose (4).
3. Remove bolts (2) from cover (3).
4. Remove cover (3).
5. Remove gasket (5).
6. Replace with new gasket.
7. Install cover (3) on block.

NOTE

Tighten bolts (2) in the sequence illustrated in Figure 4-18.

8. Install bolts (2) and tighten to 10 lb-ft.

- 9. Install hose (4).
- 10. Tighten hose clamp (1) to 20 lb-ft.

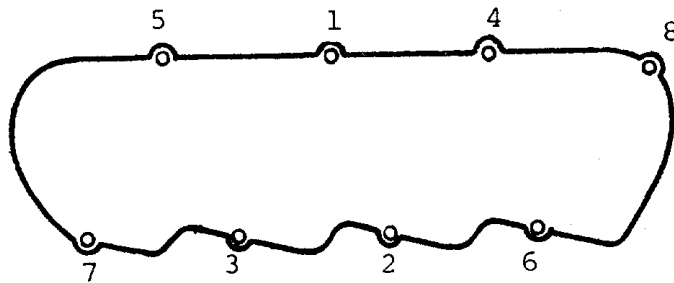
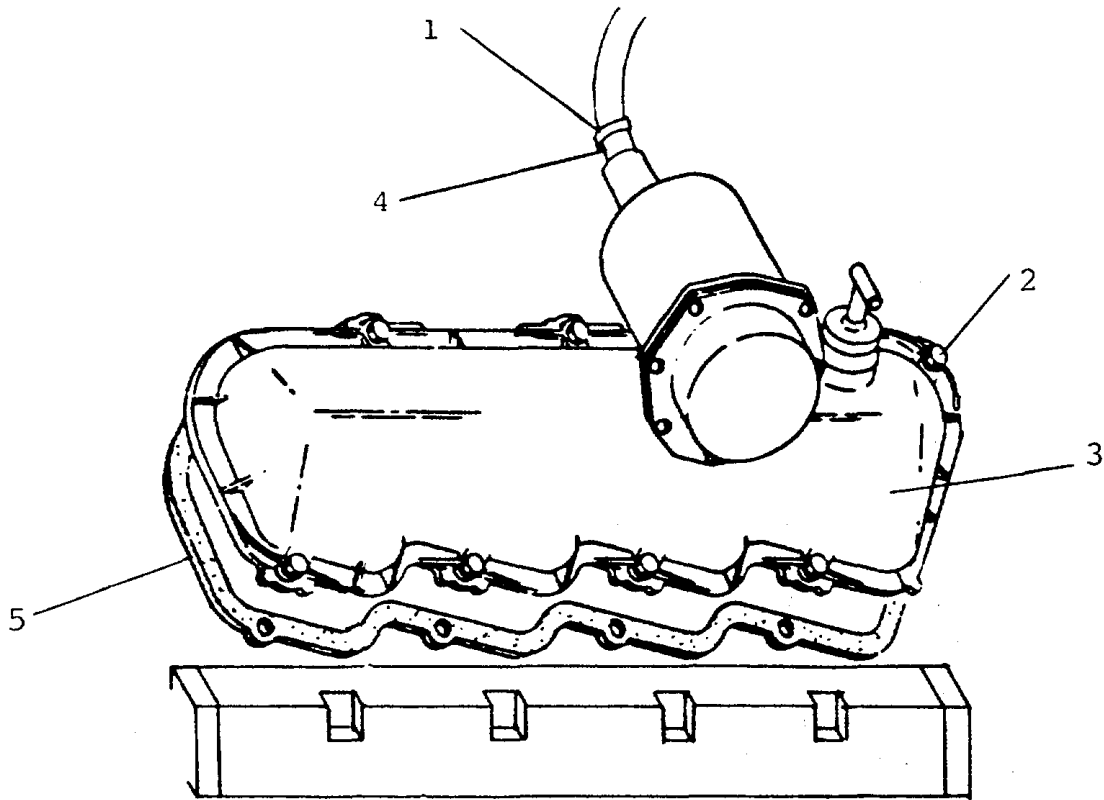

Figure 4-18. Mechanical Cover Assembly.

4-31. REPLACE AIR LINES ASSEMBLY

This Task Covers: a. Inspect b. Replacement

INITIAL SETUP

Tools Required

Tool Kit, General Mechanics
(Appendix B, Item 1)

Equipment Conditions

Engine Shutdown (para 2-11).
Battery Disconnected (para 4-58).
PCV Lines Removed (para 4-33).
Air Filter Removed (para 4-49).

Materials/Parts Required

Cotton Rags (Appendix E,
Item 3)
Seal P/N 4L8337
Gasket P/N 7W9706

Personnel Required

1 person

INSPECT (Figure 4-19.)

1. Inspect for damage to housing (1).
2. Inspect for loose bolts (3).

REPLACEMENT

1. Loosen and remove bolts (3) and washers (4).
2. Loosen and remove nuts (6).
3. Remove elbow (1).
4. Remove gasket (5).
5. Replace with new gasket.
6. Inspect seal (2).
7. Replace seal (2) if required.
8. Install elbow (1).
9. Install and tighten nuts (6).
10. Install bolts (3), washers (4), and tighten.

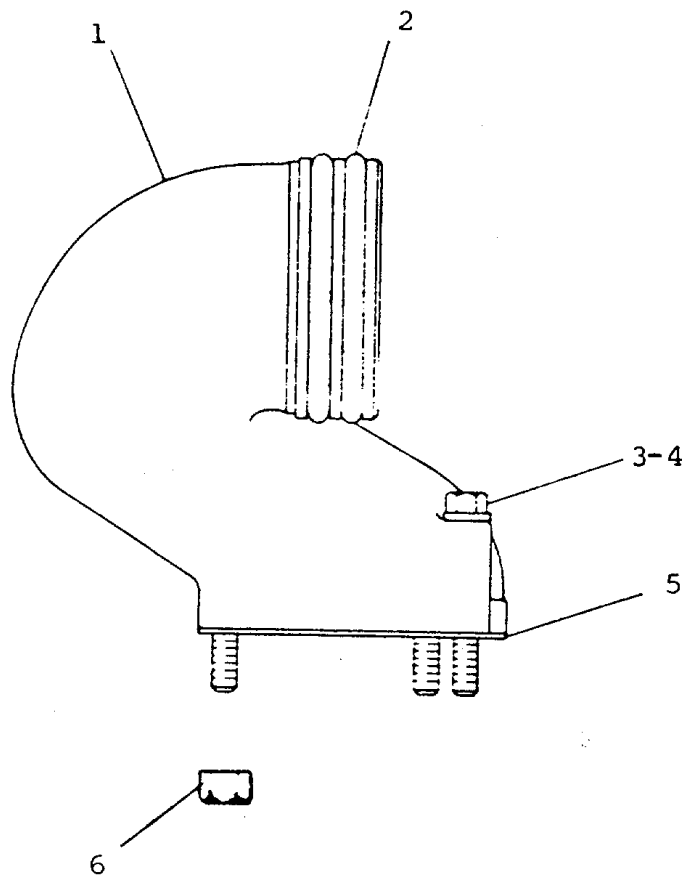

Figure 4-19. Air Lines Assembly

4-32. REPAIR/REPLACE OIL FILTER ASSEMBLY

This Task Covers: a. Inspect b. Service c. Repair d. Replacement

INITIAL SETUP**Tools Required**

Tool Kit, General Mechanics
(Appendix B, Item 1)

Materials/Parts Required

Cotton Rags (Appendix E,
Item 3)
Filter Element P/N PH3545

Equipment Conditions

Engine Shutdown (para 2-11).
Battery Disconnected (para 4-58).

Personnel Required

1 person

INSPECT (Figure 4-20.)

1. Inspect for loose filters (4).
2. Inspect for loose bolts (1).
3. Inspect for leaks.

SERVICE

1. Remove filter element (4).
2. Install new filter element.

REPAIR Repair is limited to the replacement of defective parts.

REPLACEMENT

1. Loosen and remove oil line (6).
2. Loosen and remove oil line (5).
3. Remove filters (4).
4. Loosen and remove bolts (1).
5. Remove base (3) from bracket (2).
6. Install base onto bracket.

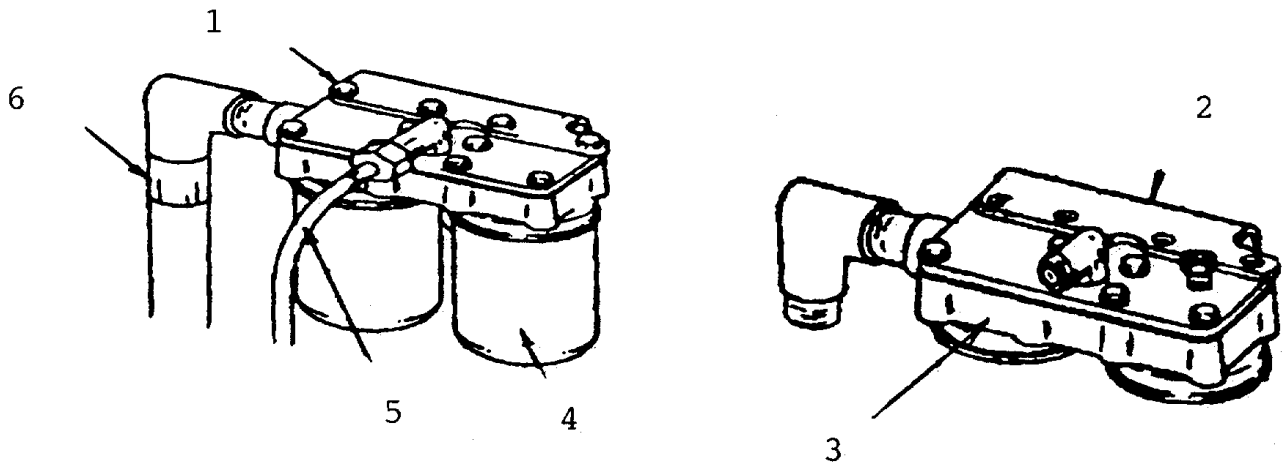

Figure 4-20. Oil Filter Assembly

7. Install and tighten bolts (1).
8. Install filters.
9. Install oil line (5).
10. Install oil line (6).
11. Start and run engine.
12. Refer to L05-2010-205-12 for lubrication instructions.

4-33. REPAIR/REPLACE PCV LINES ASSEMBLY

This Task Covers: a. Inspect b. Repair c. Replacement

INITIAL SETUPTools Required

Tool Kit, General Mechanics
(Appendix B, Item 1)

Materials/Parts Required

Cotton Rags (Appendix E,
Item 3)
Gasket Sealing Compound
(Appendix E, Item 6)
Gasket P/N 9L8786
Gasket P/N 9L8837

Equipment Conditions

Engine Shutdown (para 2-11).
Battery Disconnected (para 4-58).
Air Intake Filter Removed
(para 4-49).
Mechanical Covers Removed
(para 4-50).

Personnel Required

1 Person

INSPECT (Figures 4-21 and 4-22.)

1. Inspect for loose bolts (15).
2. Inspect for loose screws (2).
3. Inspect for damaged hoses (18).

REPAIR Repair is limited to the replacement of defective parts.

REPLACEMENT

1. Remove bolts (15) from valve cover (17).
2. Remove locks (16), and gasket (20).
3. Remove housing assembly (1) from valve cover (17).

NOTE

To disassemble and reassemble PCV valve (1), continue with Step 4 through 24. Go to Step 25 for disassembly and reassembly of all other parts.

4. Loosen and remove screws (2).
5. Remove cover (3) and spring (4).
6. Remove sleeve (9), retainer (8), and diaphragm (7) as a unit.
7. Remove sleeve (6).
8. Remove gasket (5).
9. Remove nut (12) and washer (13).
10. Remove spacer (11).
11. Remove retainer (8).
12. Separate piston (10) and diaphragm (7) from sleeve (9).
13. Put gasket sealing compound on both sides of new gasket (5).
14. Install sleeve (6) in housing (1).
15. Put piston (10) in position next to diaphragm (7).
16. Install retainer (8) in diaphragm (7).
17. Put screw (19) through sleeve (9), retainer (8), piston (10), and diaphragm (7).
18. Install spacer (11), washer (13), and nut (12) on the screw (19).

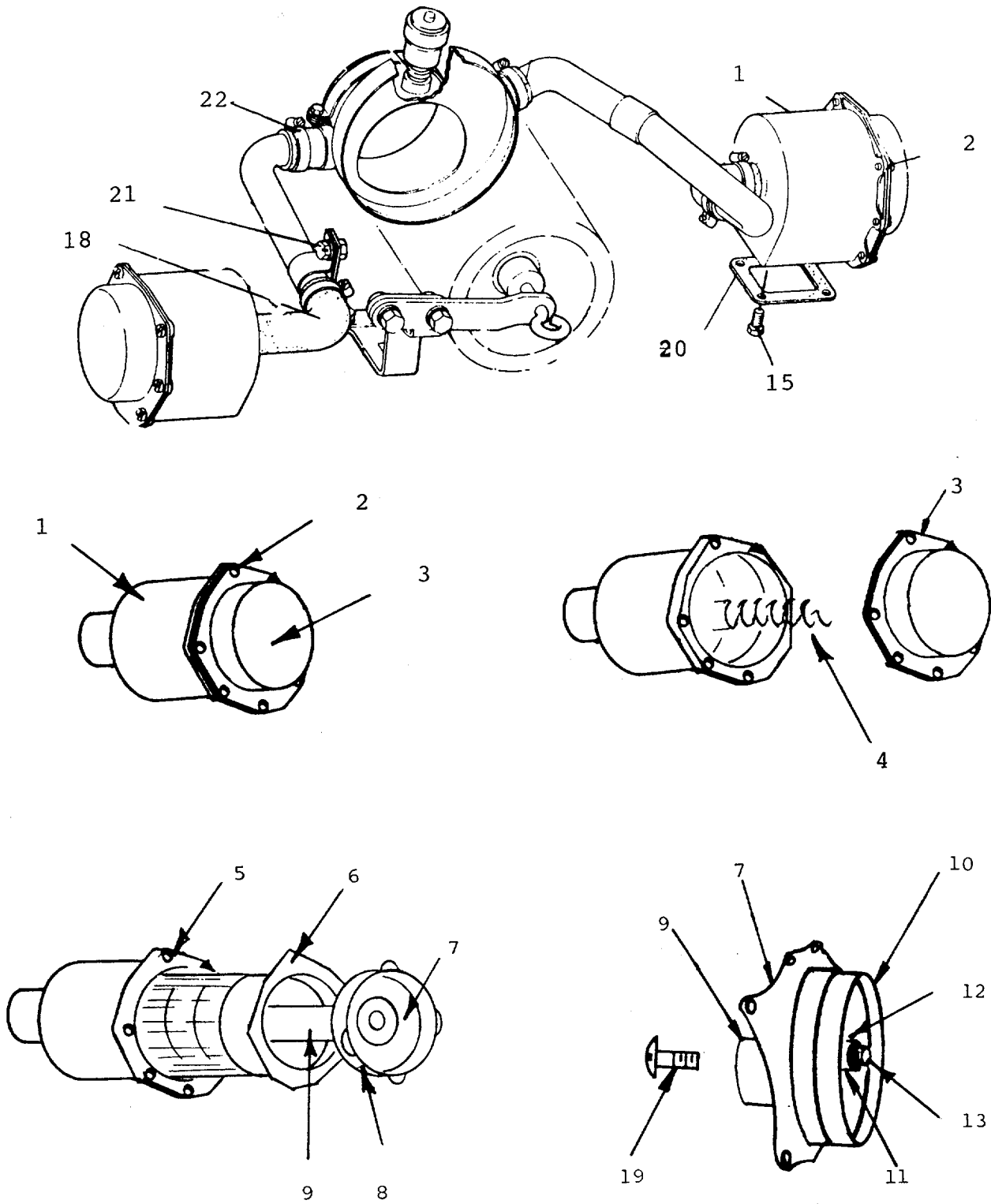

Figure 4-21. PCV lines Assembly

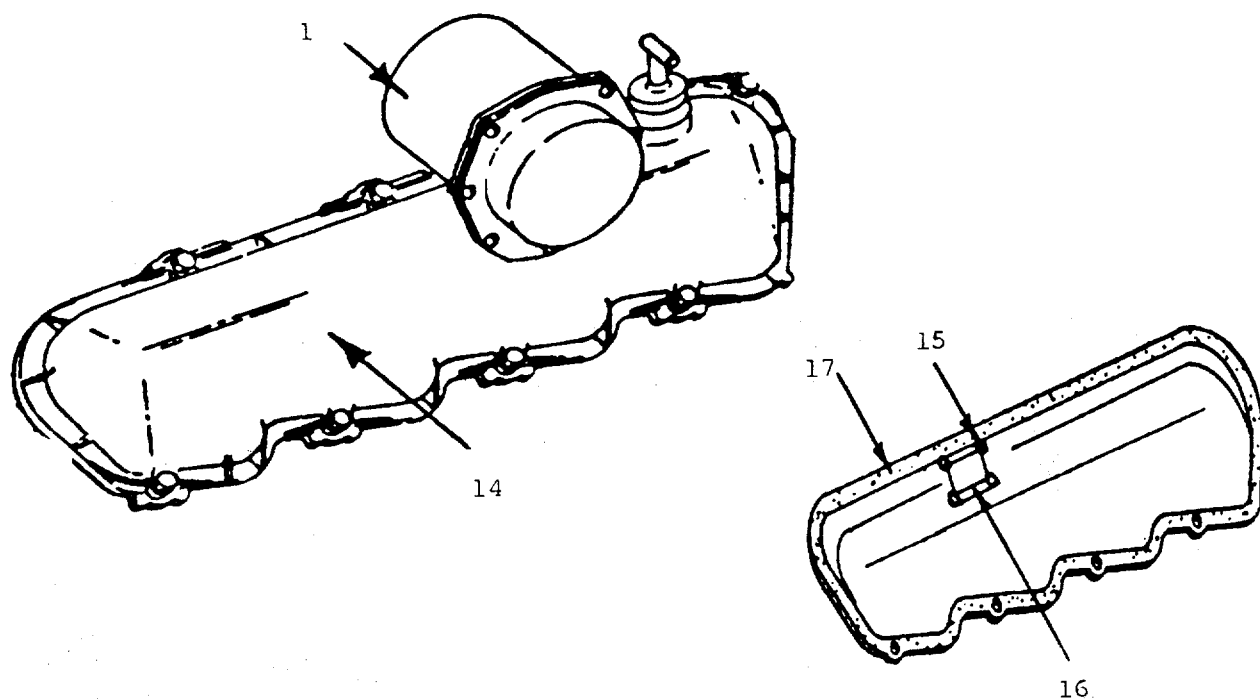

Figure 4-22. PCV Lines Assembly

19. Put gasket sealing compound on contact surfaces of diaphragm (7).
20. Install sleeve, retainer, diaphragm, and piston assembly in inner sleeve (6).
21. Install inner sleeve assembly (6) in housing (1).
22. Install spring (4) in housing (1).
23. Install cover (3) onto housing (1).
24. Install and tighten screws (2).
25. Loosen bolts (21), typical.
26. Loosen and remove hose clamps (22), typical.
27. Remove hoses (18), typical.
28. Install hoses (18).
29. Install hose clamps.
30. Install bolts (21) and tighten.

4-34. REPLACE LIFTING ASSEMBLY

This Task Covers: a. Inspect b. Replacement

INITIAL SETUP**Tools Required**

Tool Kit, General Mechanics
(Appendix B, Item 1)

Equipment Conditions

Engine Shutdown (para 2-11).-
Battery Disconnected (para 4-58).

Materials/Parts Required

Gasket P/N 9N1828

Personnel Required

1 Person

INSPECT

1. Inspect for loose bolts (2).
2. Inspect for damaged bracket (1).

REPLACEMENT

1. Loosen and remove bolts (2) and washers (3).
2. Remove bracket (1).
3. Remove gasket (4).
4. Install new gasket.
5. Install bracket.
6. Install bolts (2) and washers (3).

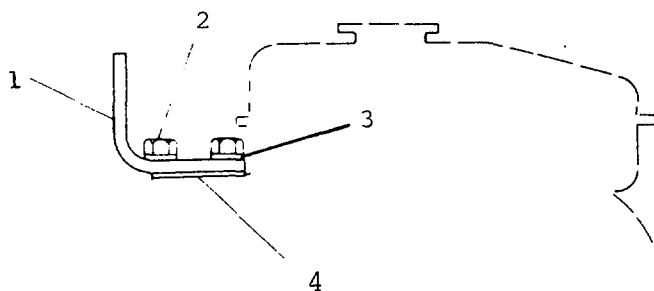

Figure 4-22. Lifting Assembly

4-35. REPAIR/REPLACE TURBOCHARGER LINES ASSEMBLY

This Task Covers: a. Inspect b. Repair c. Replacement

INITIAL SETUPTools Required

Tool Kit, General Mechanics
(Appendix B, Item 1)

Equipment Conditions

Engine Shutdown (para 2-11).
Battery Disconnected (para 4-58).

Materials/Parts Required

Cotton Rags (Appendix E,
Item 3)
Gasket P/N 1S4810
Gasket P/N 1S6595
Seal P/N 5P7530
Seal P/N 5P9890
Seal P/N 8M5127

Personnel Required

1 Person

INSPECT (Figure 4-23.)

1. Inspect for loose bolts (2), typical.
2. Inspect for damaged lines (3) and (13).

REPAIR Repair is limited to replacement of defective parts.

REPLACEMENT

1. Loosen and remove bolts (2).
2. Loosen tubing nut (5) and remove tubing (3).
3. Remove gasket (1).
4. Loosen and remove bolts (4).
5. Loosen tubing nut (12).
6. Remove tubing assembly (13).
7. Remove gasket (14).
8. Remove seal (11).

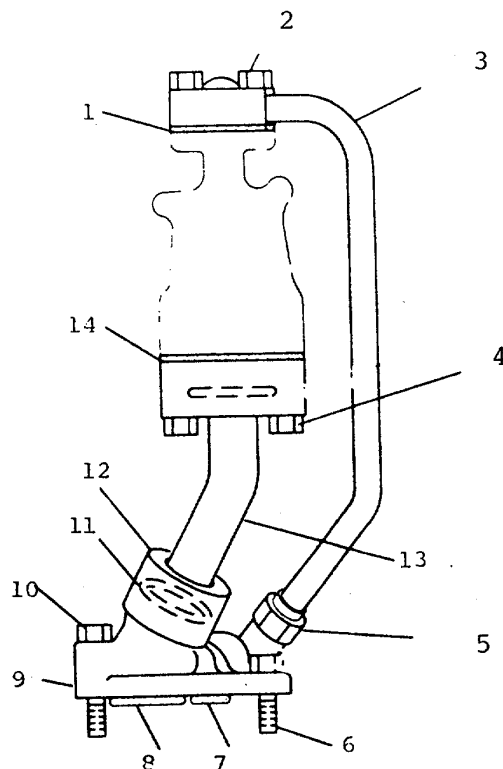

Figure 4-23. Turbocharger Lines Assembly

9. Loosen and remove bolts (10) and (6).
10. Remove connector (9).
11. Remove seals (8) and (7).
12. Install new seals (8) and (7).
13. Install connector (9).
14. Install and tighten bolts (10) and (6).
15. Install new seal (11).
16. Install new gasket (14).
17. Install tubing assembly (13).
18. Tighten tubing nut (12).
19. Install and tighten bolts (4).
20. Install new gasket (1).
21. Install tubing (3) and tighten nut (5).
22. Install and tighten bolts (2).

4-36. REPLACE ENGINE OIL LINES ASSEMBLY

This Task Covers: a. Inspect b. Replacement

INITIAL SETUP**Tools Required**

Tool Kit, General Mechanics
(Appendix B, Item 1)

Equipment Conditions

Engine Shutdown (para 2-11).
Battery Disconnected (para 4-58).

Materials/Parts Required

Cotton Rags (Appendix E,
Item 3)
Hose P/N 1N3134
Hose P/N 1N3133

Personnel Required

1 Person

INSPECT (Figure 4-24.)

1. Inspect for loose hose connections.
2. Inspect for leaks.

REPLACEMENT

1. Loosen connections (1).
2. Remove hose assembly (4).
3. Loosen connections (2).
4. Remove hose assembly (3).
5. Install hose assembly (3).
6. Tighten connections (2).
7. Install hose assembly (4).
8. Tighten connections (1).

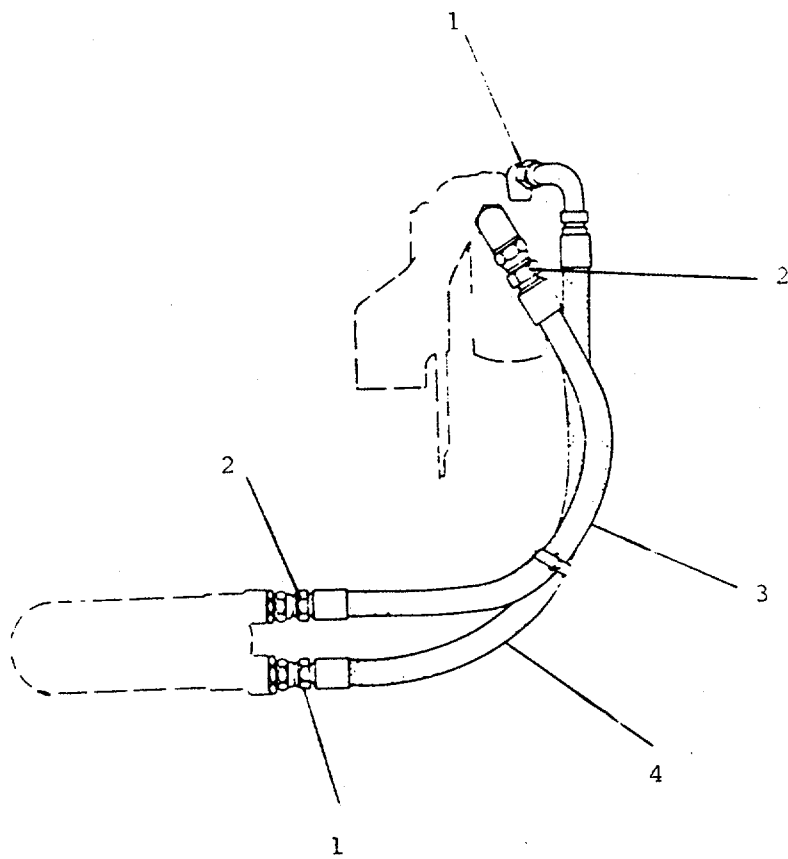

Figure 4-24. Engine Oil Lines Assembly

4-37. FASTENER ASSEMBLY

This Task Covers: a. Inspect

INITIAL SETUP

Tools Required

Tool Kit, General Mechanics
(Appendix B, Item 1)

Equipment Conditions

Engine Shutdown (para 2-11).
Battery Disconnected (para 4-58).

Materials/Parts Required

Cotton Rags (Appendix E,
Item 3)

Personnel Required

1 Person

INSPECT (Figure 4-25.)

1. Inspect for loose bolts (1).
2. Inspect for leaks at seal (2).

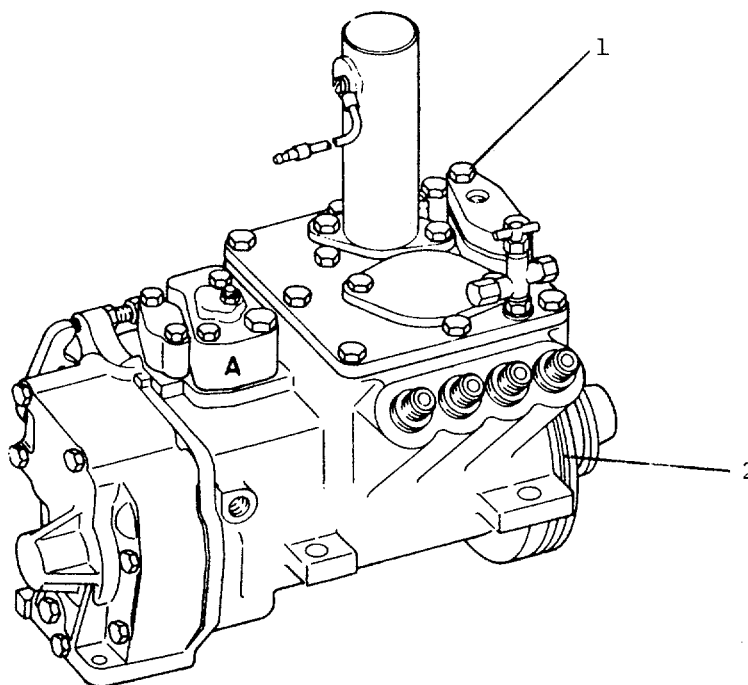

Figure 4-25. Fastener Assembly

4-38. CYLINDER HEAD ASSEMBLY

This Task Covers: a. Inspect

INITIAL SETUP

Tools Required

Tool Kit, General Mechanics
(Appendix B, Item 1)

Equipment Conditions

Engine Shutdown (para 2-11).
Battery Disconnected (para 4-58).

Materials/Parts Required

Cotton Rags (Appendix E,
Item 3)

Personnel Required

1 Person

INSPECT (Figure 4-26.)

1. Inspect for loose bolts (1).
2. Inspect for oil leaks.

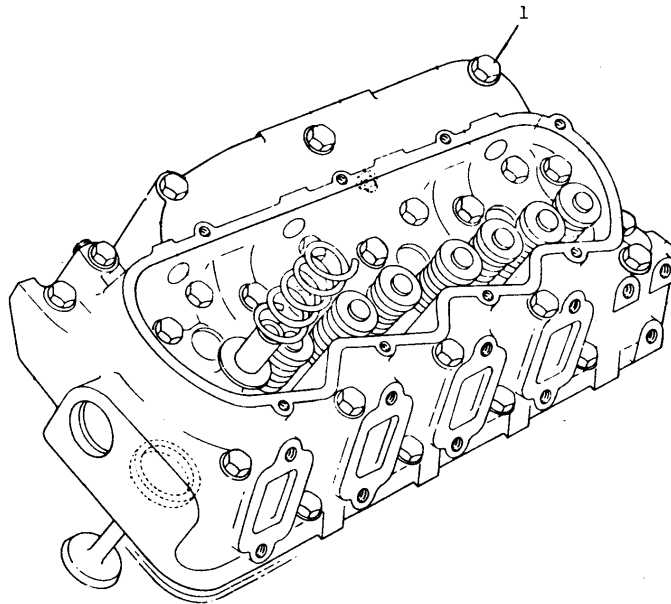

Figure 4-26. Cylinder Head Assembly

4-39. VALVE MECHANISM ASSEMBLY

This Task Covers: a. Inspect

INITIAL SETUP

Tools Required

Tool Kit, General Mechanics
(Appendix B, Item 1)

Equipment Conditions

Engine Shutdown (para 2-11).
Battery Disconnected (para 4-58).
PCV Lines Removed (para 4-33).
Valve Cover Removed (para 4-30).

Materials/Parts Required

Cotton Rags (Appendix E,
Item 3)

Personnel Required

1 Person

INSPECT

1. Inspect for loose nuts (1).
2. Inspect rocker arm (2) for cracks or damage.

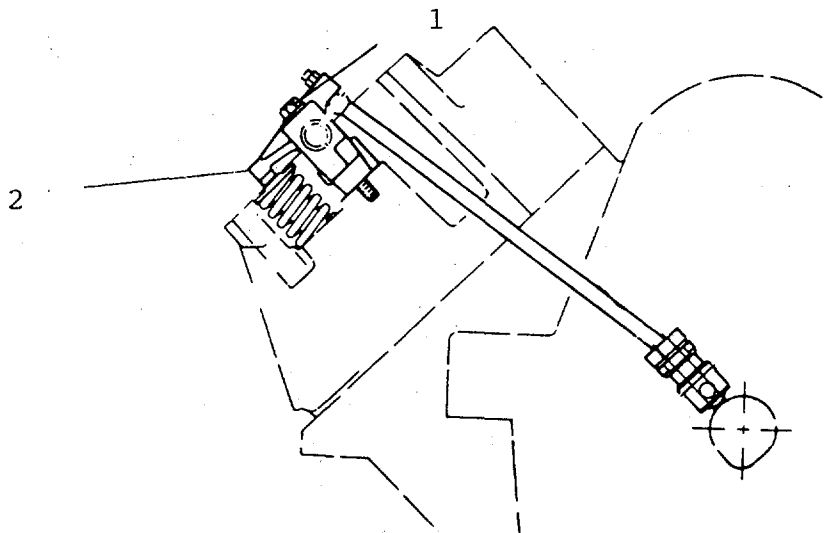

Figure 4-27. Valve Mechanism Assembly

4-40. REPLACE MANIFOLD ASSEMBLY

This Task Covers: a. Inspect b. Replacement

INITIAL SETUP**Tools Required**

Tool Kit, General Mechanics
(Appendix B, Item 1)

Materials/Parts Required

Cotton Rags (Appendix E, Item 3)
Lubricating Oil (Appendix E,
Item 2)
Masking Tape (Appendix E,
Item 7)
Gasket P/N 7C0939
Manifold P/N 8N1298

Equipment Conditions

Engine Shutdown (para 2-11).
Battery Disconnected (para 4-58).
Air Filter Removed (para 4-49).
PCV Lines Removed (para 4-33).
Fuel Injection Lines Removed
(para 4-29).

Personnel Required

1 Person

INSPECT (Figure 4-28.)

1. Inspect for loose bolts (6) through (13).
2. Inspect for loose pipe plug (1).
3. Inspect for cracks.

REPLACEMENT

1. Loosen and remove bolts (6) through (13) and washers (3).
2. Remove manifold (4) from block (2).
3. Remove gaskets (5).
4. Install new gaskets (5).
5. Install manifold.

CAUTION

Not following the bolt tightening sequence will result in air system leaks.

6. Install bolts (8) and (9) and washers (3).
7. Tighten to 15 lb-ft.
8. Install bolts (6), (7) and (10) through (13) with washers (3).
9. Tighten bolts (6) through (13) in sequence to 32 lb-ft.

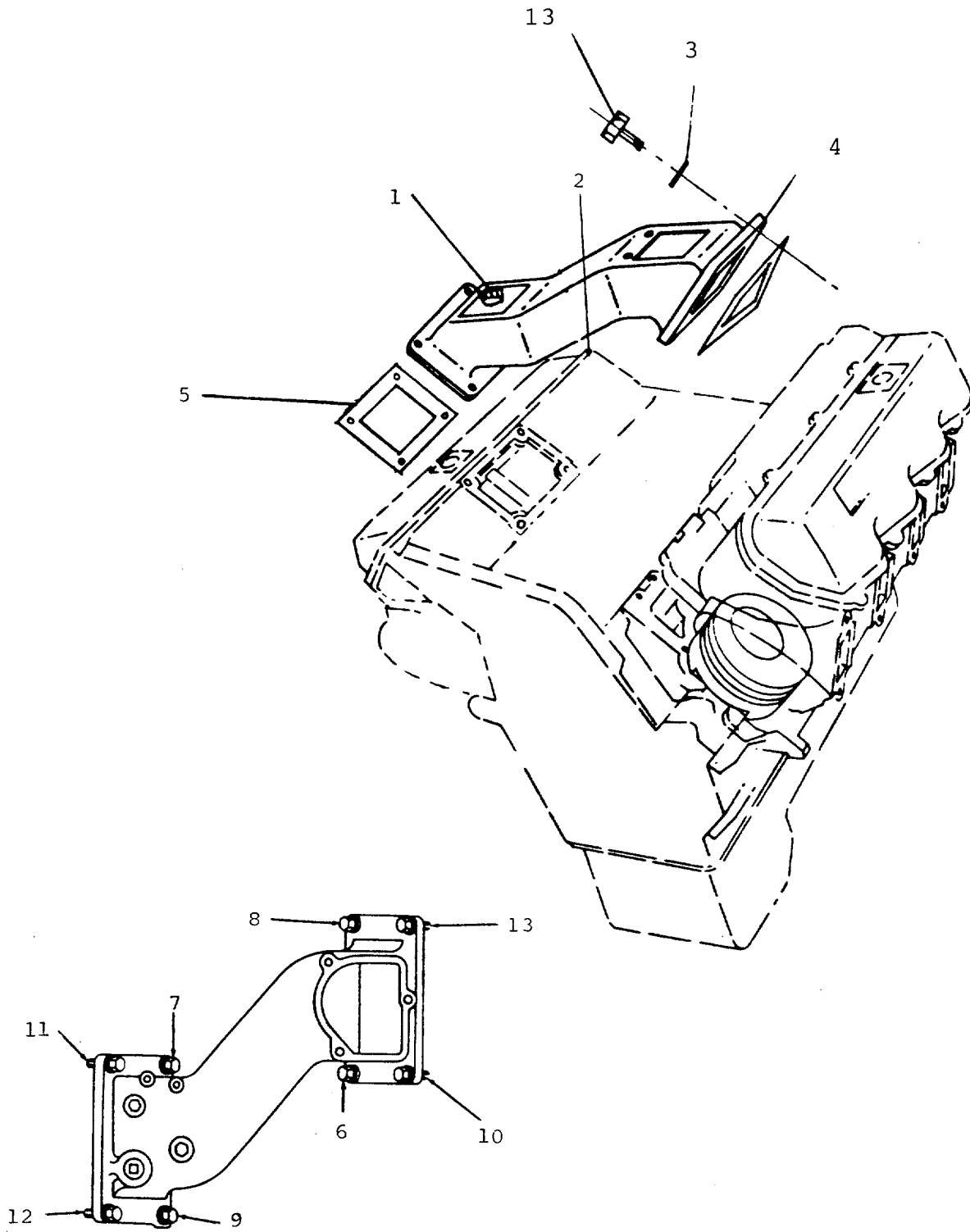

Figure 4-28. Manifold Assembly

4-41. REPAIR/REPLACE WATER PUMP ASSEMBLY

This Task Covers: a. Inspect b. Repair c. Replacement

INITIAL SETUP**Tools Required**

Tool Kit, General Mechanics
(Appendix B, Item 1)

Materials/Parts Required

Cotton Rags (Appendix E,
Item 3)
Permanent Antifreeze
(Appendix E, Item 4)
Gasket P/N 9N0137
Seal P/N 2W0712
Water Pump Assembly P/N 9N6147

Equipment Conditions

Engine Shutdown (para 2-11).
Battery Disconnected (para 4-58).
Squirrel Cage Fan Removed
(para 4-59).
Guard Removed (para 4-48).

Personnel Required

1 Person

INSPECT (Figure 4-29 and 4-30.)

1. Inspect for loose bolts.
2. Inspect for loose belts.

REPAIR Repair is limited to the replacement of defective parts.

REPLACEMENT

1. Remove V-belts (1) from engine.
2. Remove bolts (2).
3. Remove pointer (3).
4. Remove water pump (4).
5. Remove gasket (5).
6. Remove bolt (7).
7. Remove pulley (6).

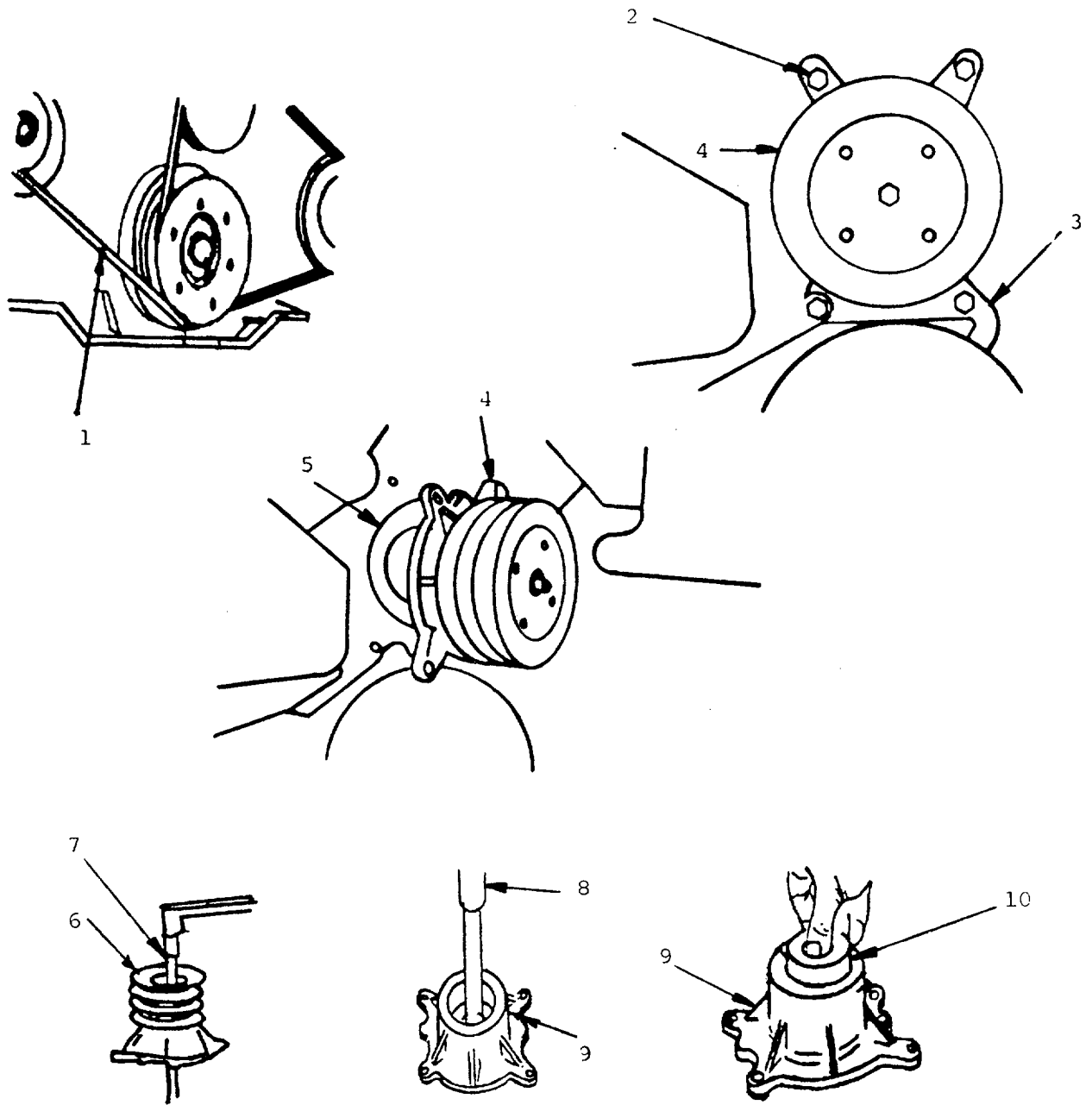

Figure 4-29. Water Pump Assembly

- 8. Remove assembly (8) from housing (9).
- 9. Remove bearing (10).
- 10. Remove spacer (11).

11. Remove ring (12).
12. Remove shaft (13) and seal (14) from impeller (15).
13. Install seal assembly (14) and shaft (13) onto impeller (15).
14. Install new seal (14) and shaft (13) in housing (9).
15. Install ring (12) in housing.
16. Install spacer (11).
17. Install bearing (10).

NOTE

The shaft (13) to bearing (10) clearance should be .0007 inch loose to .0003 inch tight.

18. Install pulley (6).
19. Tighten bolt (7) to 55 lb-ft.

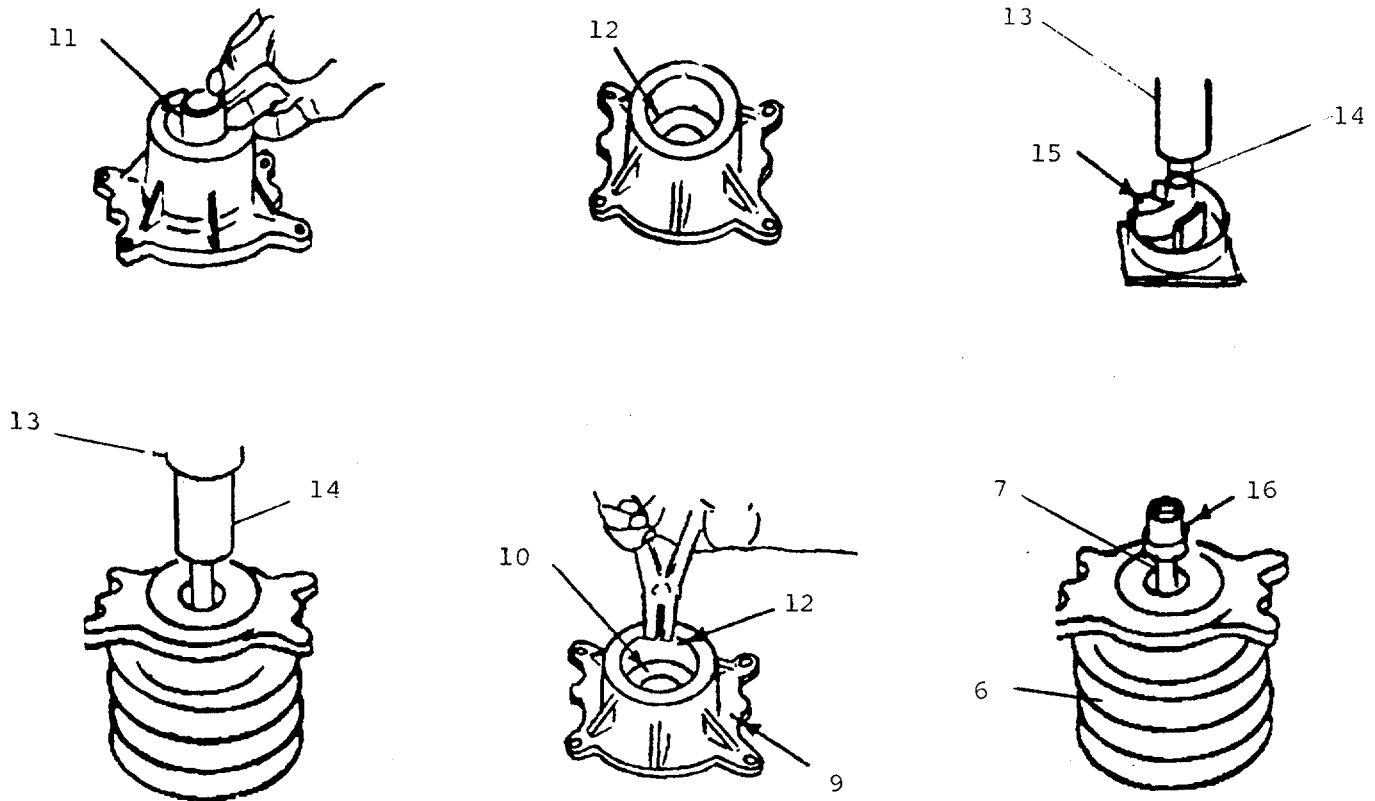

Figure 4-30. Water Pump Assembly

20. Install new seal (16).
21. Install new gasket (5).
22. Position water pump (4) and pointer (3).
23. Install bolts (2).
24. Install V-belts (1).

4-42. ENGINE SUPPORT ASSEMBLY

This Task Covers: a. Inspect

INITIAL SETUPTools Required

Tool Kit, General Mechanics
(Appendix B, Item 1)

Equipment Conditions

Engine Shutdown (para 2-11).
Battery Disconnected (para 4-58).

Materials Parts Required

None

Personnel Required

1 person

INSPECT (Figure 4-31.)

1. Inspect for loose bolts (2).
2. Inspect for damage to bracket (1).

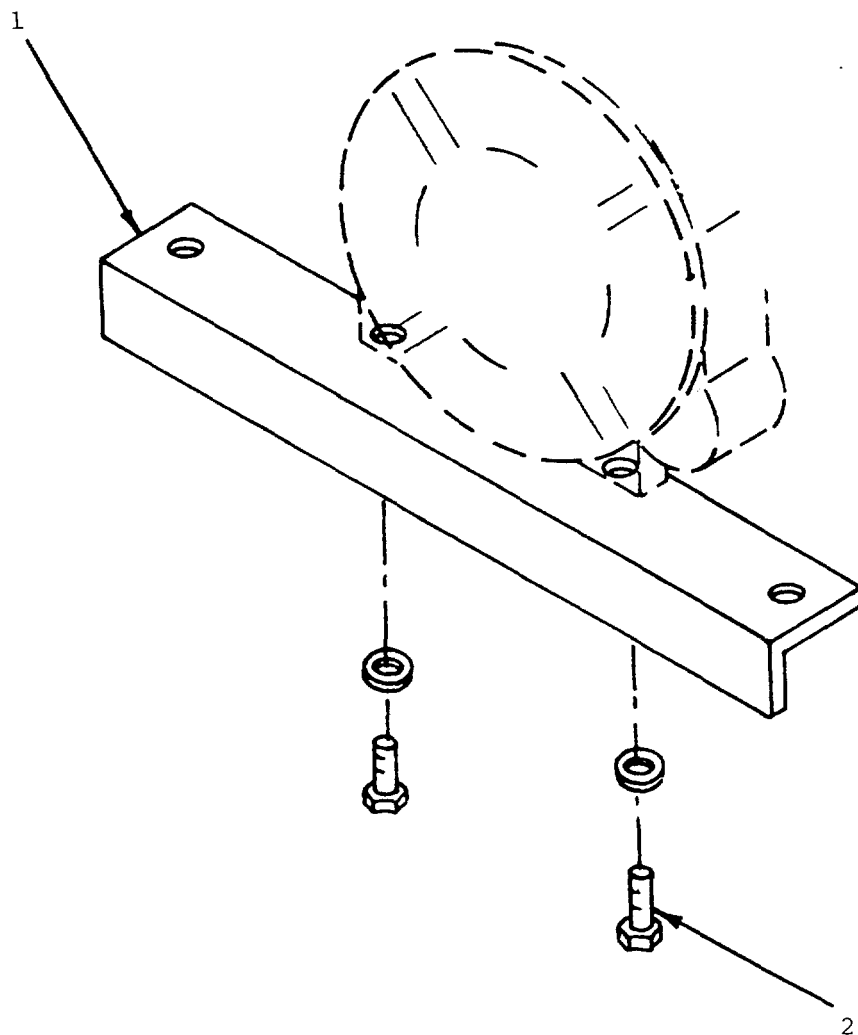

Figure 4-31. Engine Support Assembly.

4-43. REPLACE PULLEY AND DAMPER ASSEMBLY

This Task Covers: a. Inspect b. Replacement

INITIAL SETUP

Tools Required

Tool Kit, General Mechanics
(Appendix B, Item 1)
Puller Assembly (Appendix B, Item 9)
Puller (Appendix B, Item 5)

Equipment Conditions

Engine Shutdown (para 2-11).
Battery Disconnected (para 4-58).
Squirrel Case Fan Removed (para 4-59).
Guard Removed (para 4-48).

Material Parts Required

Cotton Rags (Appendix E, Item 3)
Lubricating Oil (Appendix E, Item 2)

Personnel Required

1 Person

INSPECT

1. Inspect for loose bolt (3).
2. Inspect for loose V-belts (1).

REPLACEMENT

1. Remove V-belts (1).
2. Remove bolt (3) and washer (2).
3. Remove pulley (4) using puller assembly (5).
4. Install pulley (4).
5. Install washer (2) and bolt (3).
6. Install V-belts (6).

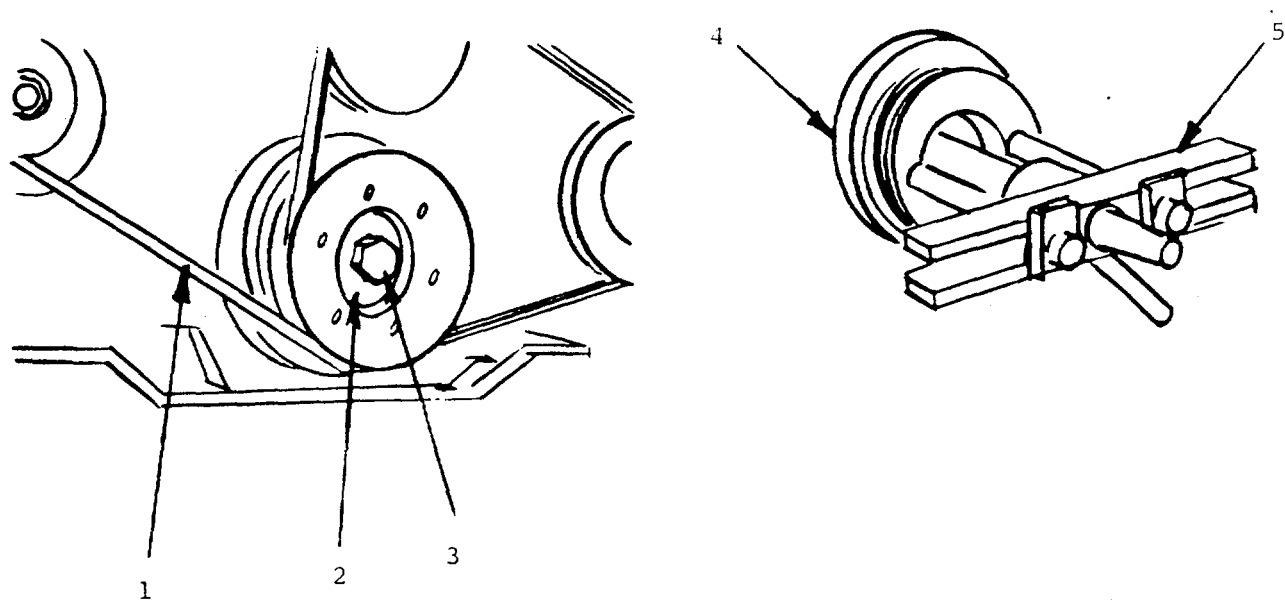

Figure 4-32. Pulley and Damper Assembly

4-44. REPLACE STARTER MOTOR ASSEMBLY

This Task Covers: a. Inspect b. Replacement

INITIAL SETUP

Tools Required

Tool Kit, General Mechanics
(Appendix B, Item 1)

Equipment Conditions

Engine Shutdown (para 2-11).
Battery Disconnected (para 4-58).

Materials/Parts Required

Cotton Rags (Appendix E,
Item 3)

Personnel Required

2 Persons

INSPECT (Figure 4-33.)

1. Inspect for cleanliness of electrical connections.
2. Inspect for loose assembly bolts.
3. Inspect for loose electrical connections.

REPLACEMENT

1. Disconnect wires to starter (2).
2. Remove bolts (1).
3. Remove starter.
4. Install starter.
5. Install bolts and tighten.
6. Connect wires to starter.

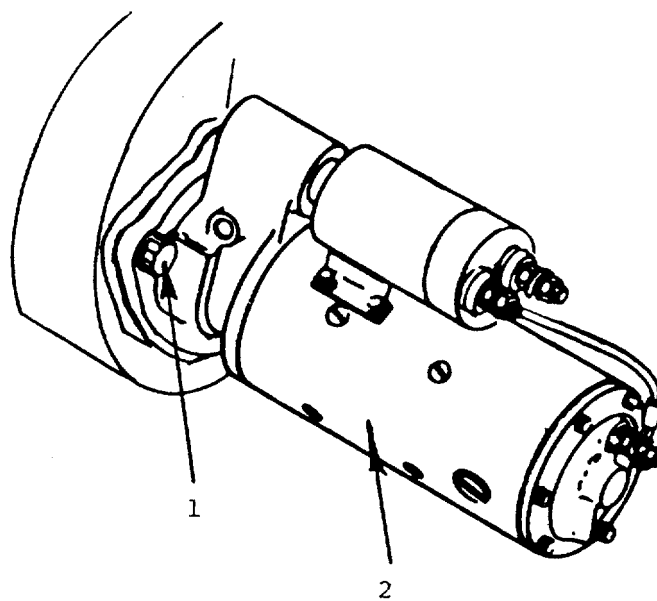

Figure 4-33. Starter Motor Assembly

4-45. REPLACE WIRING ASSEMBLY

This Task Covers: a. Inspect b. Replacement

INITIAL SETUPTools Required

Tool Kit, General Mechanics
(Appendix B, Item 1)

Equipment Conditions

Engine Shutdown (para 2-11).
Battery Disconnected (para 4-58).

Materials/Parts Required

Cotton Rags (Appendix E,
Item 3)

Personnel Required

1 Person

INSPECT (Figure 4-34.)

1. Inspect for cleanliness on all terminal connections.
2. Inspect for loose connections.

REPLACEMENT**NOTE**

When removing or disconnecting a group of lines or wires, tag each to assure proper assembly.

1. Loosen all terminals (2).
2. Remove wiring assembly (1).
3. Install wiring assembly.
4. Tighten all terminals.

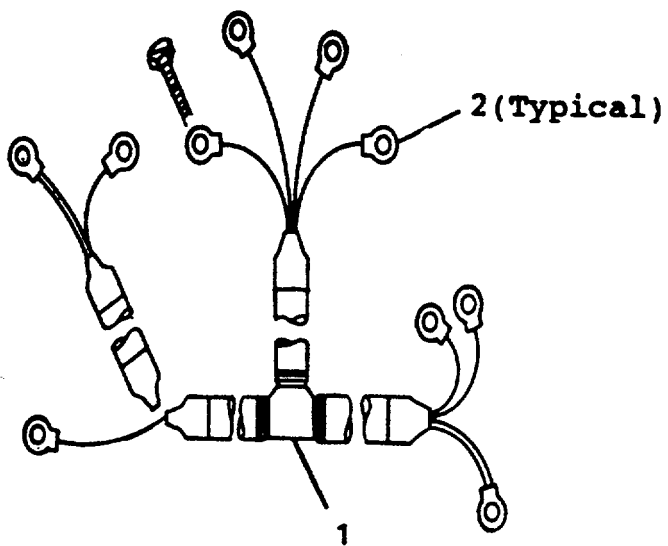

Figure 4-34. Wiring Assembly

4-46. REPLACE ALTERNATOR ASSEMBLY

This Task Covers: a. Inspect b. Replacement

INITIAL SETUPTools Required

Tool Kit, General Mechanics
(Appendix B, Item 1)

Equipment Conditions

Engine Shutdown (para 2-11).
Battery Disconnected (para 4-58).
Squirrel Cage Fan Removed
(para 4-59).
Guard Removed (para 4-48).

Materials/Parts Required

Cotton Rags (Appendix E,
Item 3)

Personnel Required

1 Person

INSPECT (Figure 4-35.)

1. Inspect for loose bolts.
2. Inspect belt for damage.

REPLACEMENT

1. Disconnect wire (5) from alternator (3).
2. Loosen bolts (1) and (4).
3. Remove belt (2).
4. Remove bolts (1) and (4).
5. Remove alternator (3).
6. Install alternator.
7. Install bolts but do not tighten.
8. Install belt.
9. Adjust belt tension and tighten bolts.
10. Connect wire (5) to alternator.

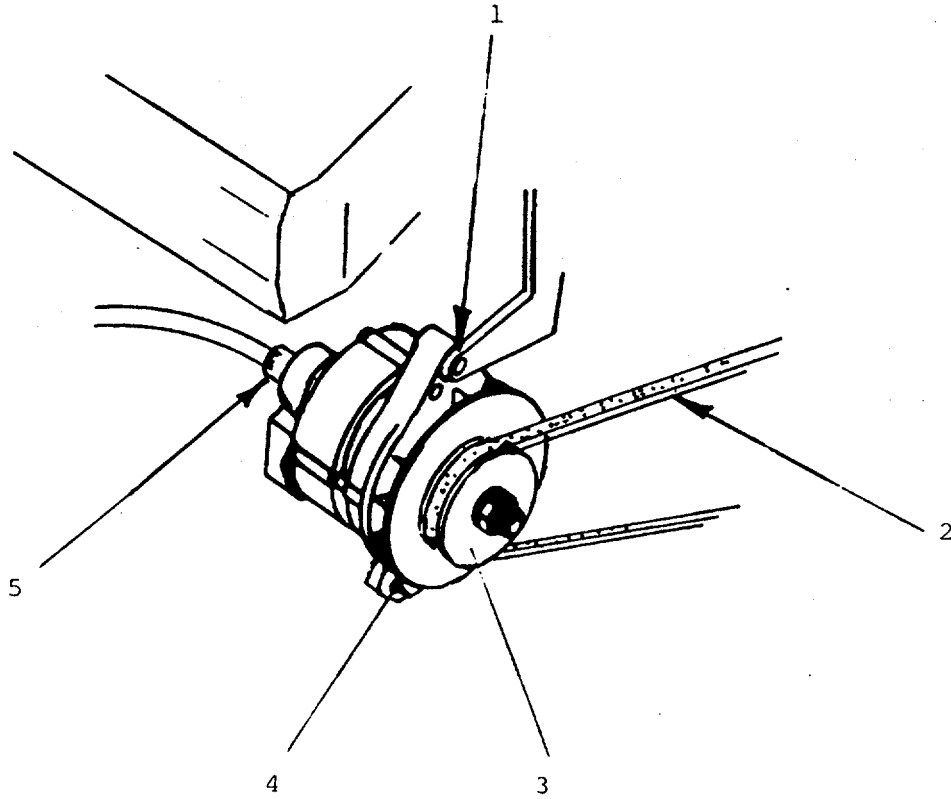

Figure 4-35. Alternator Assembly

4-47. REPLACE AUXILIARY PUMP ASSEMBLY

This Task Covers: a. Inspect b. Replacement

INITIAL SETUP

Tools Required

Tool Kit, General Mechanics
(Appendix B, Item 1)

Materials/Parts Required

Cotton Rags (Appendix E,
Item 3)

Equipment Conditions

Engine Shutdown (para 2-11).
Battery Disconnected (para 4-58).
Squirrel Cage Fan Removed
(para 4-59).
Guard-Removed (para 4-48).

Personnel Required

1 Person

INSPECT (Figure 4-36.)

1. Inspect for loose bolts.
2. Inspect for leaks.
3. Inspect belt for damage.

REPLACEMENT

1. Loosen bolts (2).
2. Remove belt (1).
3. Disconnect inlet (8) and outlet (7) hoses.
4. Remove bolts (6) and washers (5) from bracket (4).
5. Remove pump (9).
6. Install pump (9) to bracket (4).
7. Install and tighten bolts (6) and washers (5).
8. Connect inlet and outlet hoses.
9. Install belt and adjust tension.
10. Tighten bolts (2).

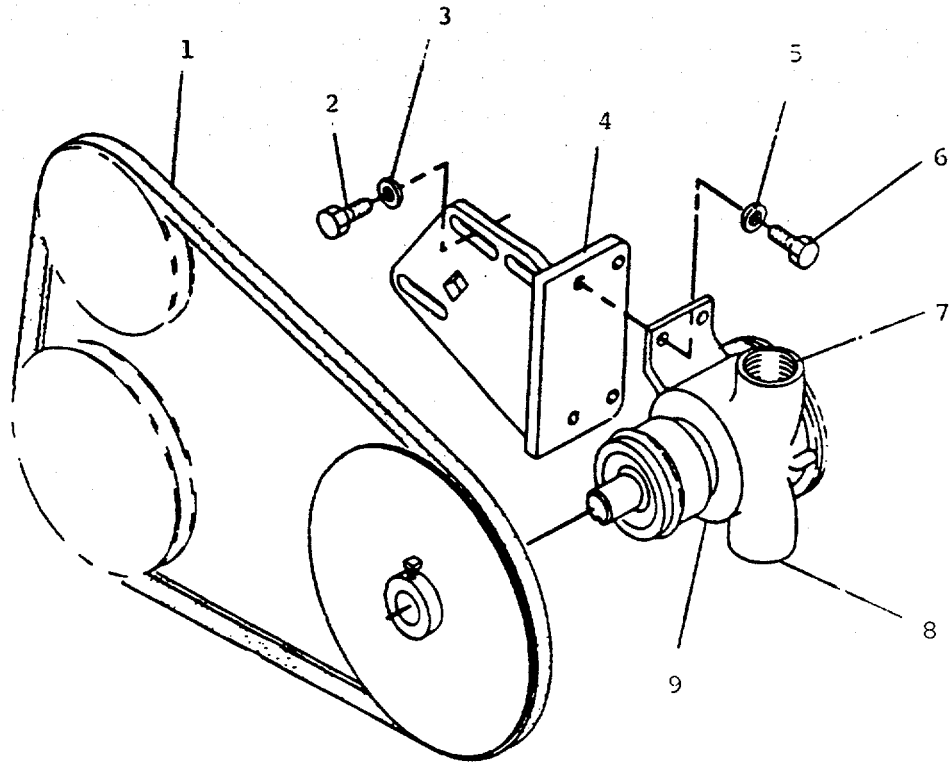

Figure 4-36. Auxiliary Pump Assembly

4-48. REPLACE GUARD ASSEMBLY

This Task Covers: a. Inspect b. Replacement

INITIAL SETUP**Tools Required**

Tool Kit, General Mechanics
(Appendix B, Item-1)

Equipment Conditions

Engine Shutdown (para 2-11).
Battery Disconnected (para 4-58).
Squirrel Cage Removed
(para 4-59).

Materials/Parts Required

Cotton Rags (Appendix E,
Item 3)
Guard Assembly P/N 2W9559

Personnel Required

1 Person

INSPECT (Figure 4-37.)

1. Inspect for loose bolts.
2. Inspect for damage.

REPLACEMENT

1. Loosen and remove bolts (2) and washers (3) from brackets (1).
2. Loosen and remove bolts (4) and washers (3) from bracket (5).
3. Remove guard (6).
4. Install guard (6).
5. Install and tighten bolts (4) and washers (3) to bracket (5).
6. Install and tighten bolts (2) and washers (3) to brackets (1).

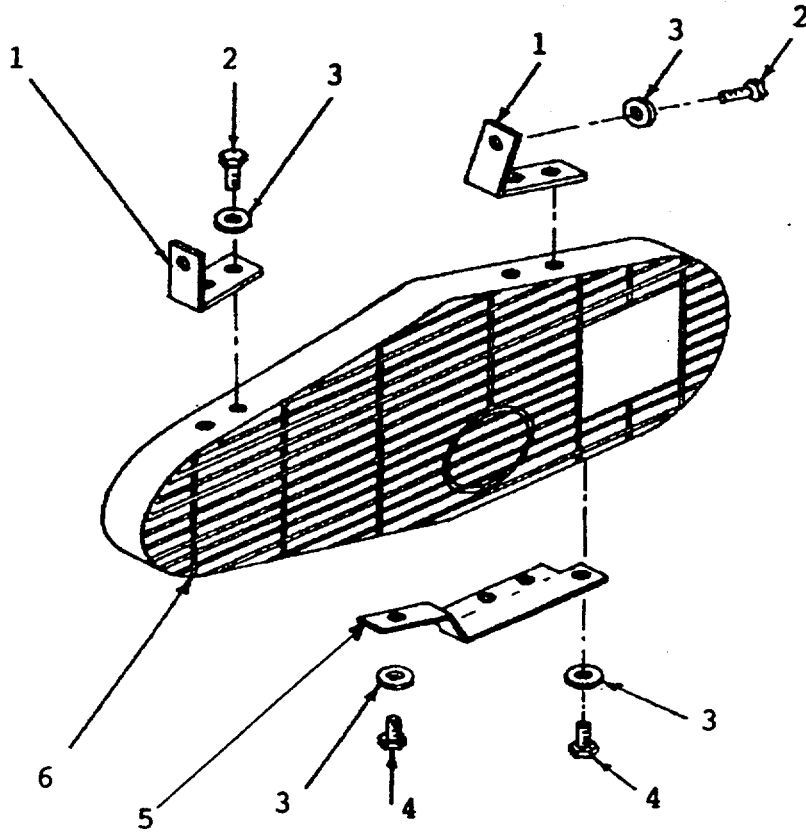

Figure 4-37. Guard Assembly

4-49. REPIACE AIR INTAKE FILTER ASSEMBLY

This Task Covers: a. Inspect b. Service c. Replacement

INITIAL SETUP**Tools Required**

None

Materials/Parts Required

Cotton Rags (Appendix E, Item 3)
Filter Element P/N 7W5040

Equipment Conditions

Engine Shutdown (para 2-11).
Battery Disconnected (para 4-58).

Personnel Required

1 Person

INSPECT (Figure 4-38).

1. Inspect for loose thumbscrew.
2. Inspect for damage.

SERVICE Refer to Table 2-1., Operator's PMCS.

REPLACEMENT

1. Loosen thumbscrew (1).
2. Remove filter (2).
3. Install new filter (2).
4. Tighten thumbscrew (1).

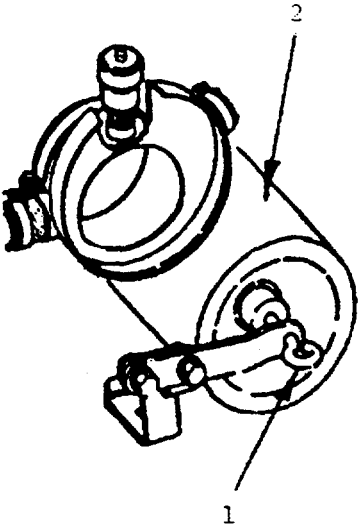

Figure 4-38. Air Intake Filter Assembly

4-50. REPLACE MUFFLER AND PIPE ASSEMBLY

This Task Covers: a. Inspect b. Replacement

INITIAL SETUP

Tools Required

Tool Kit, General Mechanics
(Appendix B, Item 1)

Materials/Parts Required

Cotton Rags (Appendix E,
Item 3)
Gasket P/N P05001
Gasket P/N 48-40
Muffler P/N DCU-04-0410
Adapter P/N 64-40
Adapter P/N C100454
Elbow P/N C100453
Elbow P/N 56-40

Equipment Conditions

Engine Shutdown (para 2-11).
Battery Disconnected (para 4-58).

Personnel Required

2 Persons

INSPECT (Figure 4-39.)

1. Inspect for loose bolts.
2. Inspect for holes, rust, and obvious damage.
3. Inspect for free movement of rain-cap (1).

REPLACEMENT

1. Loosen nut (2) and remove rain-cap (1).
2. Loosen nuts (3) typical and remove section (14), elbow (13), and adaptor (12).
3. Loosen and remove bolts (4), nuts (6), and washer (5).
4. Remove section (12), and gasket (15).
5. Remove bolts (4), washers (5), and nuts (6).
6. Remove muffler (11).
7. Remove bolts (7) and washers (8).

8. Remove elbow (9).
9. Remove gasket (10).
10. Install new gasket (10).

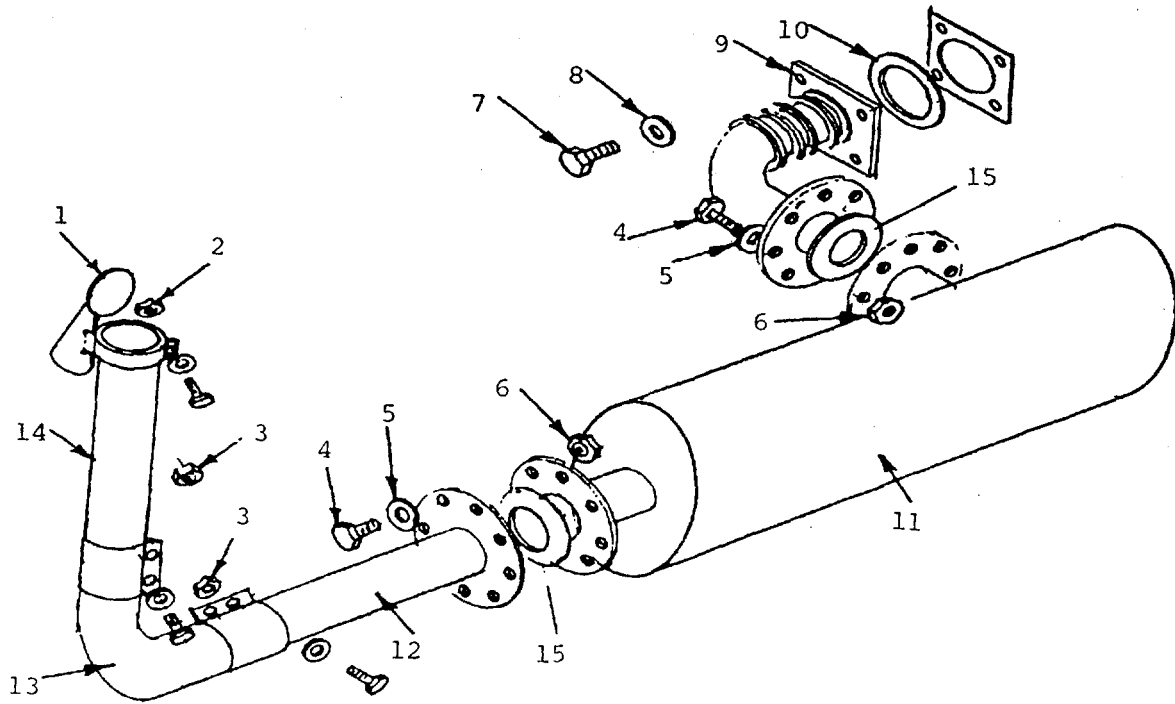

Figure 4-39. Muffler and Pipe Assembly

11. Install elbow (9).
12. Install bolts (7) and washers (8).
13. Install muffler (11).
14. Install section (12) and new gasket (15).
15. Install bolts (4), washers (5), and nuts (6).
16. Install section (14) and elbow (13).
17. Tighten nuts (3).
18. Install rain-cap (1).
19. Tighten nut (2).

4-51. HYDRAULIC PUMP ASSEMBLY

This Task Covers: a. Inspect

INITIAL SETUPTools Required

Tool Kit, General Mechanic
(Appendix B, Item 1)

Equipment Conditions

Engine Shutdown (para 2-11).
Battery Disconnected (para 4-58).

Materials/Parts Required

Cotton Rags (Appendix E,
Item 3)

Personnel Required

1 Person

INSPECT (Figure 4-40.)

1. Inspect for loose bolts (1).
2. Inspect for leaks (2).

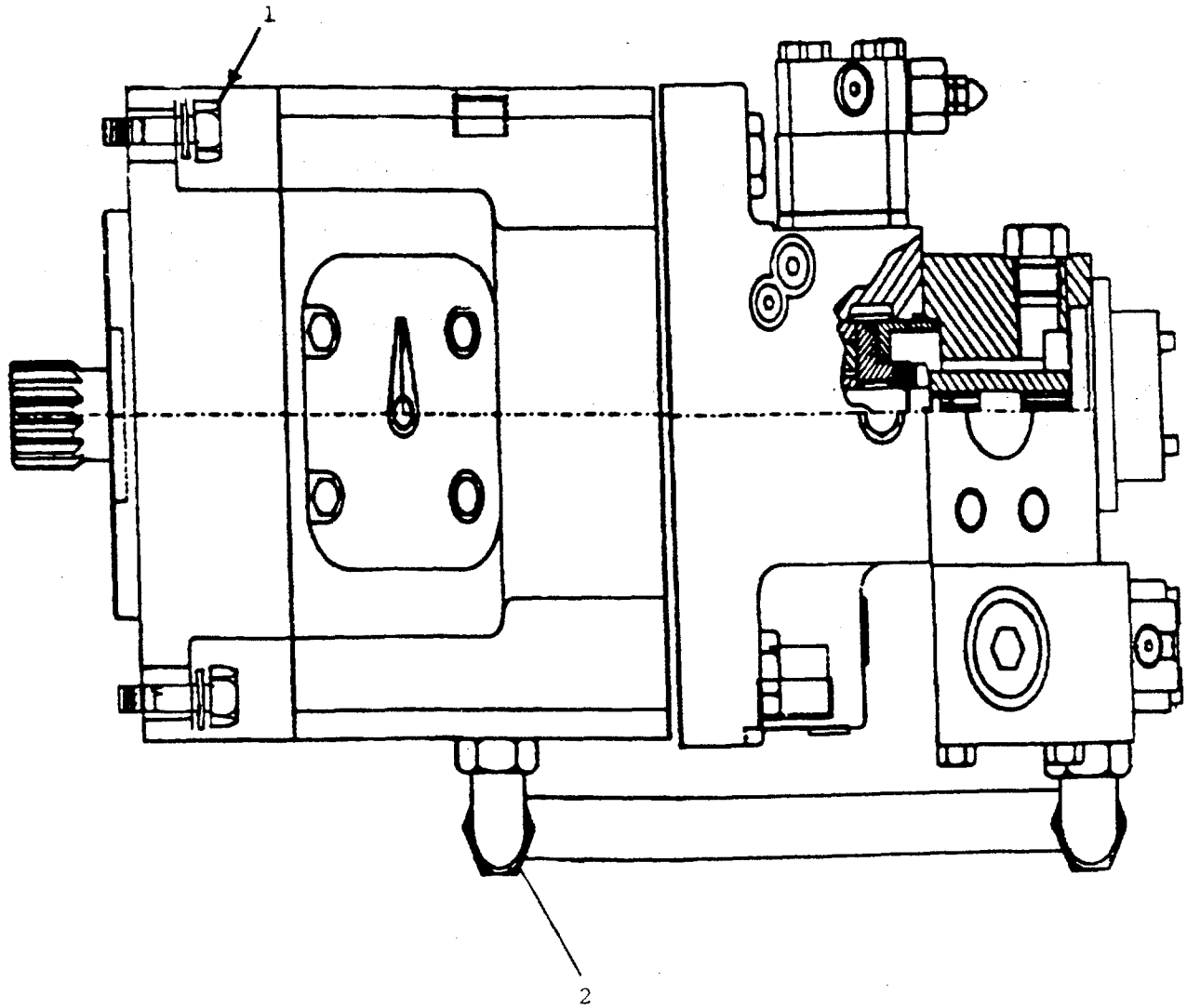

Figure 4-40. Hydraulic Pump Assembly

4-52. CONTROL PANEL ASSEMBLY

This Task Covers: a. Inspect

INITIAL SETUP**Tools Required**

Tool Kit, General Mechanics
(Appendix B, Item 1)

Materials/Parts Required

Cotton Rags (Appendix E,
Item 3)

Equipment Conditions

Engine Shutdown (para 2-11).
Battery Disconnected (para 4-58).

Personnel Required

1 person

INSPECT (Figure 4-41.)

1. Inspect for damage.
2. Inspect fire extinguisher (1) for proper charge.
3. Inspect for leaks.

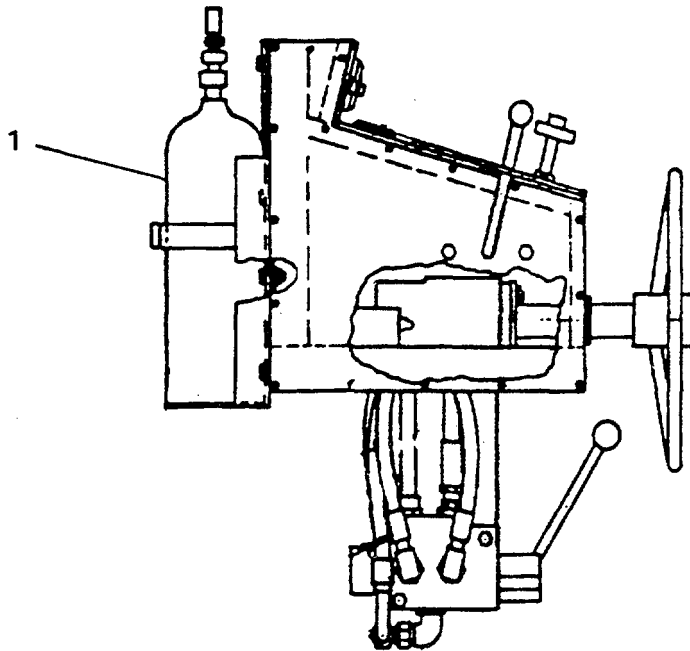

Figure 4-41. Control Panel Assembly

4-53. REPLACE HEAT EXCHANGER ASSEMBLY (HYDRAULIC OIL)

This Task Covers: a. Inspect b. Replacement

INITIAL SETUP**Tools Required**

Tool Kit, General Mechanics
(Appendix B, Item 1)

Equipment Conditions

Engine Shutdown (para 2-11).
Battery Disconnected (para 4-58).
Close Hydraulic Valve
(LO5-2010-205-12)

Materials/Parts Required

Cotton Rags (Appendix E,
Item 3)
Heat Exchanger
P/N 5-142-03-048-032

Personnel Required

2 Persons

INSPECT (Figure 4-42.)

1. Inspect for leaks.
2. Inspect for loose hose connections.
3. Inspect for loose assembly bolts.

REPLACEMENT

1. Loosen and remove hose (1).
2. Loosen and remove hose (2).
3. Loosen and remove hose (6).
4. Loosen and remove hose (8).
5. Loosen and remove hose (12).
6. Loosen and remove nuts (13) from U-bolts (3).
7. Remove heat exchanger (14).
8. Remove pipe spool (17).
9. Remove reducer (16).

10. Remove elbow (15).
11. Remove pipe (11).
12. Remove elbow (10).
13. Remove elbow (9).
14. Remove tee (7).
15. Remove coupling (5).
16. Remove elbow (4).

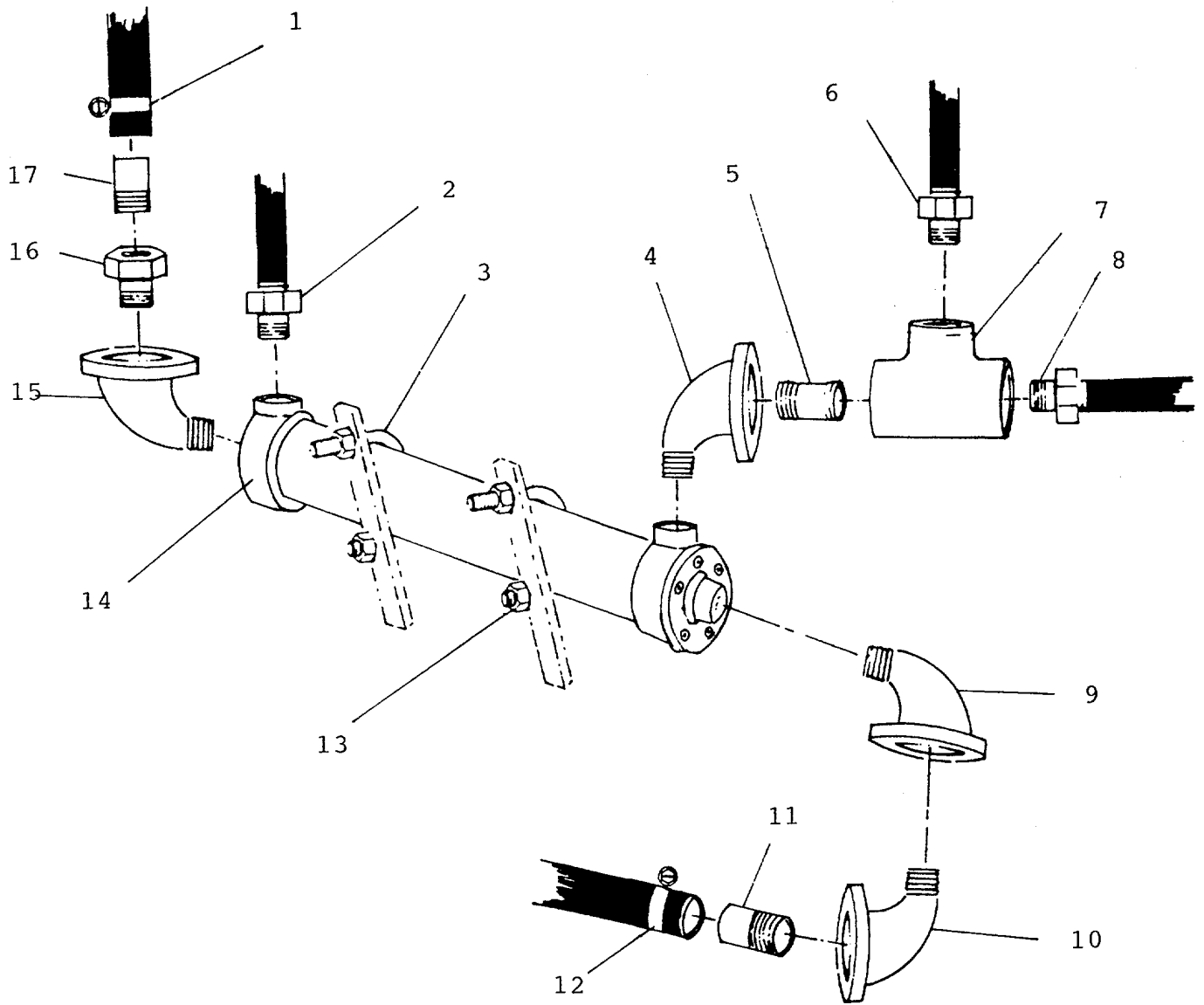

Figure 4-42. Heat Exchanger Assembly

17. Install elbow (4).
18. Install coupling (5).
19. Install tee (7).
20. Install elbow (9).
21. Install elbow (10).
22. Install pipe (11).
23. Install elbow (15).
24. Install reducer (16).
25. Install pipe spool (17).
26. Install heat exchanger (14).
27. Install U-bolts (3).
28. Install and tighten bolts (13).
29. Install hose (12).
30. Install hose (8).
31. Install hose (6).
32. Install hose (2).
33. Install hose (1).

4-54. ELECTRIC WIRING ASSEMBLY

This Task Covers: a. Inspect

INITIAL SETUPTools Required

Tool Kit, General Mechanics
(Appendix B, Item 1)

Materials/Parts Required

Cotton Rags (Appendix E,
Item 3)

Equipment Conditions

Engine Shutdown (para 2-11).
Battery Disconnected (para 4-58).

Personnel Required

1 Person

INSPECT (Figure 4-43.)

1. Inspect for loose connections.
2. Inspect for cracked or damaged wires and terminals.

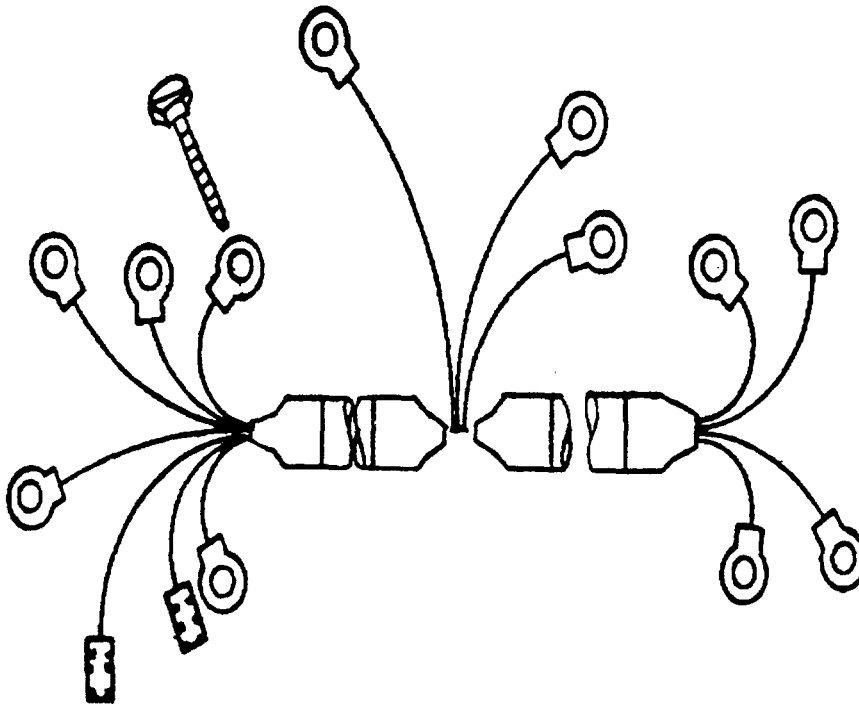

Figure 4-43. Electrical Wiring Assembly

4-55. REPLACE HYDRAULIC HOSE AND VALVE ASSEMBLY

This Task Covers: a. Inspect b. Replacement

INITIAL SETUP
Tools Required

Tool Kit, General Mechanic
(Appendix B, Item 1)

Equipment Conditions

Engine Shutdown (para 2-11).
Battery Disconnected (para 4-58).

Materials/Parts Required

Cotton Rags (Appendix E,
Item 3)
Masking Tape (Appendix E,
Item 8)

Personnel Required

1 Person

INSPECT (Figure 4-44.)

1. Inspect all hoses for loose connections.
2. Inspect for loose bolts on valve connections.
3. Inspect for leaks.
4. Inspect for obvious damage.

REPLACEMENT

CAUTION

After disconnecting a hydraulic, fuel, or lubrication line, plug or tape openings immediately.

NOTE

Before disconnecting any fuel, hydraulic, or lubricating line, clean area thoroughly.

NOTE

Leave all new hoses, fittings, and valves in their containers until ready for assembly.

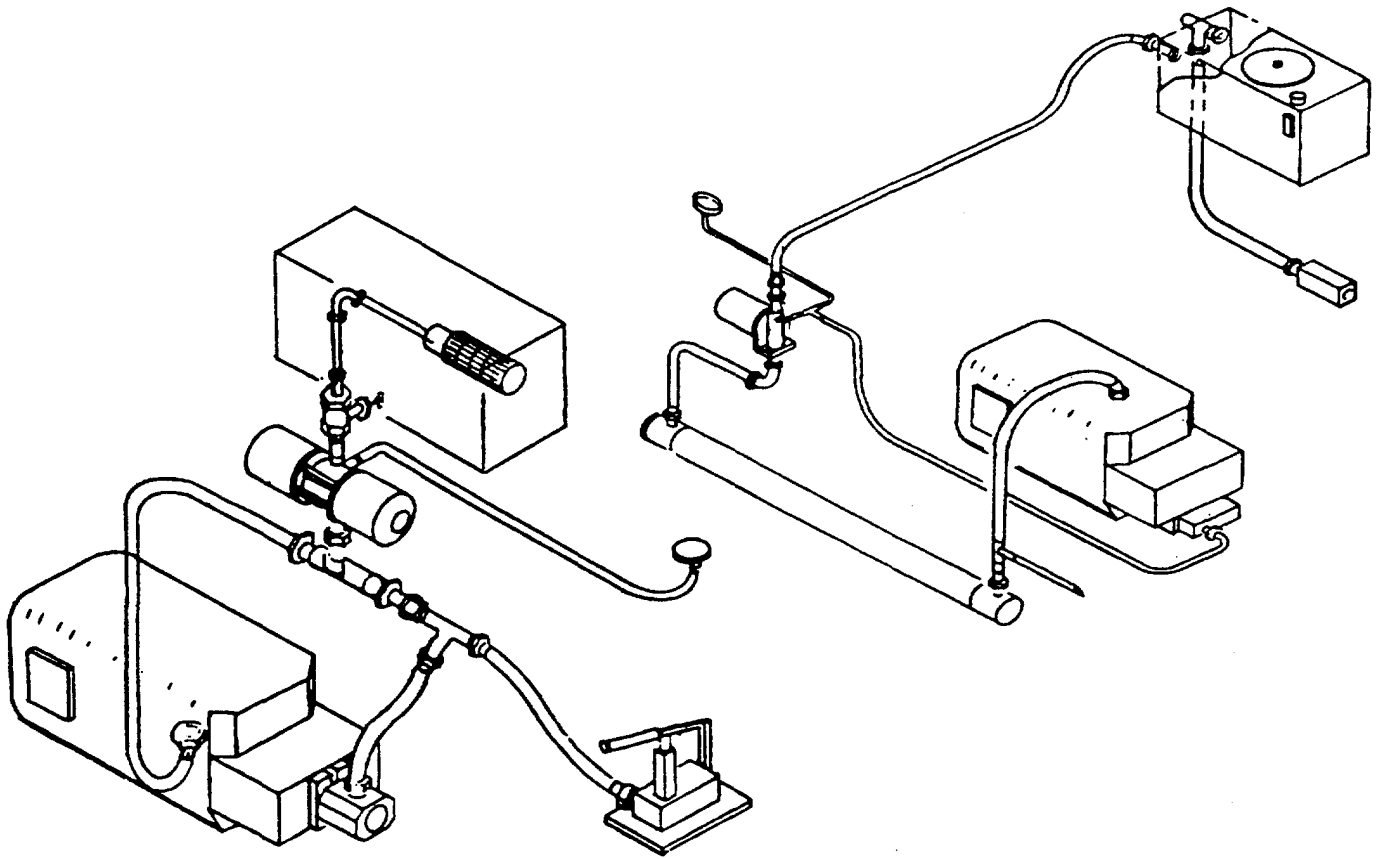

Figure 4-44. Hydraulic Hose and Valve Assembly

1. Loosen hose ends.
2. Remove damaged hose.
3. Loosen and remove assembly bolts.
4. Remove defective valve.
5. Loosen and remove defective fitting.
6. Install and tighten new fitting.
7. Install new valve.
8. Install and tighten valve assembly bolts.
9. Install new hose assembly.
10. Tighten hose ends.

4-56. REPAIR/REPLACE HYDRAULIC RESERVOIR ASSEMBLY

This Task Covers: a. Inspect b. Service c. Repair d. Replacement

INITIAL SETUPTools RequiredTool Kit, General Mechanics
(Appendix B, Item 1)Equipment ConditionsEngine Shutdown (para 2-11).
Battery Disconnected (para 4-58).Materials/Parts RequiredCotton Rags (Appendix E,
Item 3)
Pail, Metal (Appendix D,
Item 2)Personnel Required2 Persons

INSPECT (Figure 4-45.)

1. Inspect for loose assembly bolts (2, 5, 6 and 13).
2. Inspect for loose connections (9, 10, 14, and 15).
3. Inspect for leaks.

SERVICE

1. Check gauge (7). Refer to LO 5-2010-205-12.
2. Check filters (11). Refer to LO 5-2010-205-12.

REPAIR Repair is limited to replacement of defective parts.REPLACEMENT

1. Close valve (12).
2. Remove plug (8) from tank (1) and drain all oil.
3. Lift false roof (16) and block.
4. Loosen bolt (2) and remove cover (3).
5. Loosen screws (5).

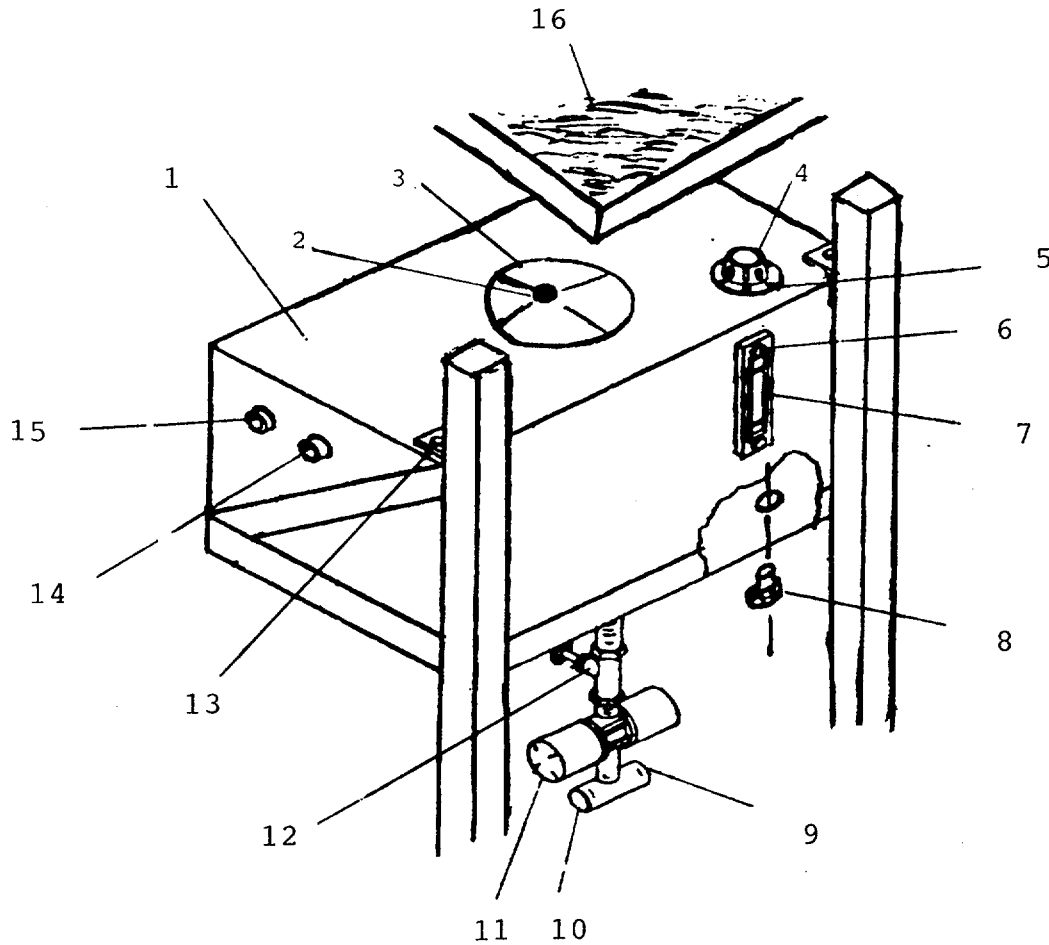

Figure 4-45. Hydraulic Reservoir Assembly

- 6. Remove vent/screen assembly (4).
- 7. Loosen and remove bolts (6).
- 8. Remove Gauge (7).

NOTE

Cover all parts as they are removed to keep them clean.

NOTE

Be sure all parts are cleaned before installing.

NOTE

Leave new parts in their containers until ready for assembly.

- 9. Install gauge (7).

10. Install and tighten bolts (6).
11. Install vent/screen assembly (4).
12. Install screws (5) and tighten.
13. Install cover (3) and tighten bolt (2).
14. Install and tighten plug (8).
15. Open valve (12).
16. Add hydraulic oil. Refer to LO 5-2010-205-12.

4-57. REPAIR/REPLACE SEAWATER COOLING ASSEMBLY

This Task Covers: a. Inspect b. Service c. Repair d. Replacement

INITIAL SETUP
Tools Required

Tool Kit, General Mechanics
(Appendix B, Item 1)

Equipment Conditions

Engine Shutdown (para 2-11).
Battery Disconnected (para 4-58).

Materials/Parts Required

Cotton Rags (Appendix E,
Item 3)
Gasket P/N 10

Personnel Required

1 Person

INSPECT (Figure 4-46. and 4-47.)

1. Inspect for loose bolts.
2. Inspect for loose pipe connections.
3. Inspect for dirt in strainer.
4. Inspect for damage.

SERVICE

1. Remove wing nut (22).
2. Remove washer (21).
3. Remove section (19).
4. Remove gasket (16).
5. Remove cylinder (17), and clean with fresh water.
6. Install cylinder (17).
7. Install new gasket (16).
8. Install section (19).
9. Install washer (21).
10. Install and tighten wing nut (22).

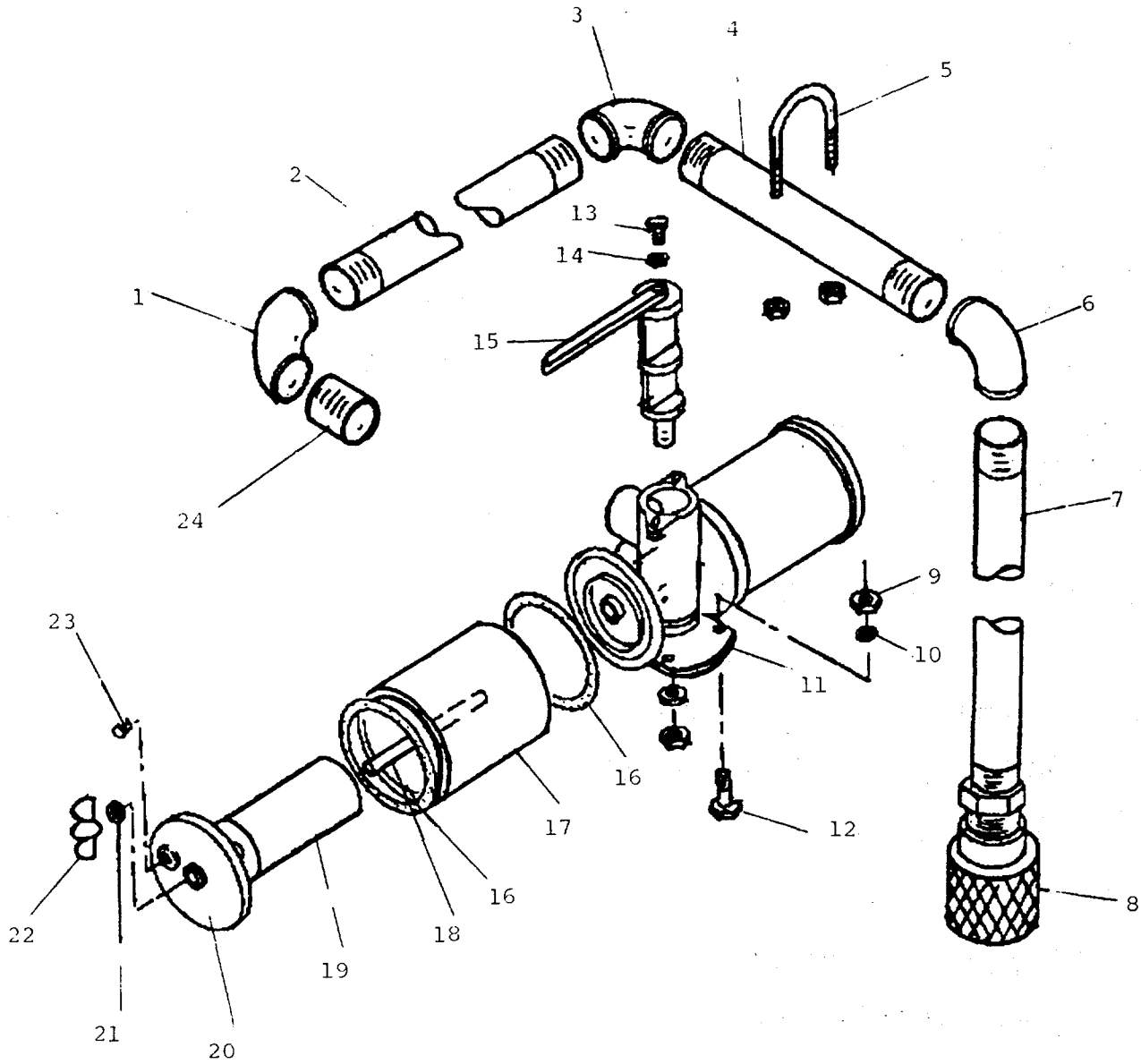

Figure 4-46. Seawater Cooling Assembly

NOTE

Repeat procedure for right side of strainer.

REPAIR Repair is limited to replacement of defective parts.

REPLACEMENT**NOTE**

Whenever lines are disconnected, first clean the point of disconnection and the adjacent area.

NOTE

Be sure all passages are clean before reinstalling.

REMOVE/REPLACE

1. Loosen and remove basket strainer (8).
2. Remove pipe section (7).
3. Remove elbow (6).
4. Loosen nuts and remove U-bolt (5).
5. Remove pipe section (4).
6. Remove elbow (3).
7. Remove pipe section (2).
8. Remove elbow (1).
9. Remove close coupling (24).
10. Remove nuts (9), washers (10), and bolts (12).
11. Remove screw (13).
12. Remove washer (14).
13. Remove valve stem (15).
14. Install valve stem (15).
15. Install washer (14).
16. Install and tighten screw (13).
17. Install bolts (12), washers (10), and nuts (9).
18. Install close coupling (24).
19. Install elbow (1).
20. Install pipe section (2).
21. Install elbow (3).

REMOVE/REPLACE

22. Install pipe section (4).
23. Install U-bolts (6) and tighten nuts.
24. Install elbow (6).
25. Install pipe section (7).
26. Install basket strainer (8) and tighten.
27. Loosen nuts and remove U-bolts (30).
28. Loosen bolts (41) and remove washers (40) and bracket (39).
29. Remove elbow (35).

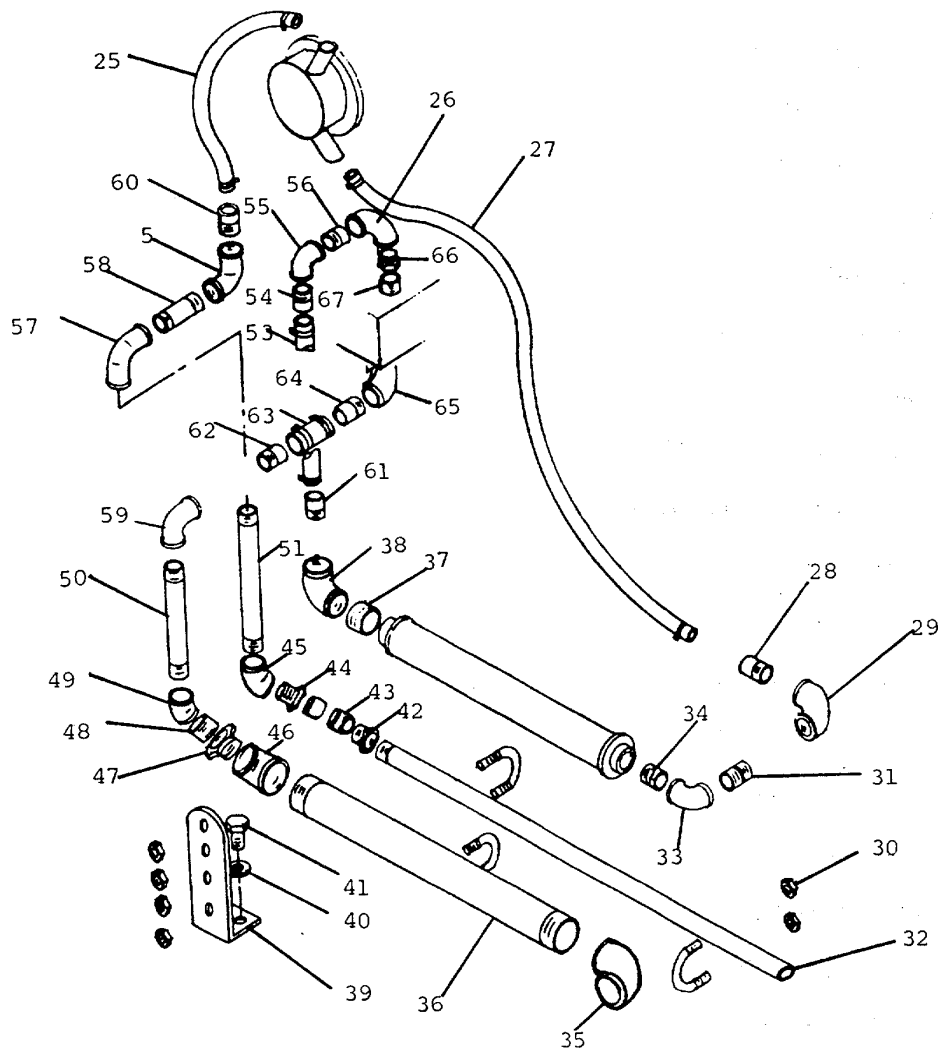

Figure 4-47. Seawater Cooling Assembly

REMOVE/REPLACE

30. Remove pipe (36).
31. Remove elbow (46).
32. Remove reducer (47).
33. Remove coupling (48).
34. Remove elbow (49).
35. Remove pipe (50).
36. Remove elbow (52).
37. Remove pipe (32).
38. Remove coupling (42).
39. Remove hose (43).
40. Remove coupling (44).
41. Remove elbow (45).
42. Remove pipe (51).
43. Remove elbow (57).
44. Remove pipe (58).
45. Remove elbow (59).
46. Remove coupling (60).
47. Remove hose (25).
48. Remove hose (27).
49. Remove coupling (28).
50. Remove elbow (29).
51. Remove nipple (31).
52. Remove elbow (33).
53. Remove nipple (34).
54. Remove coupling (62).
55. Remove hose (63).
56. Remove coupling (64).

REMOVE/REPLACE

57. Remove elbow (65).
58. Remove hose (53).
59. Remove coupling (61).
60. Remove elbow (38).
61. Remove nipple (37).
62. Remove coupling (54).
63. Remove elbow (52).
64. Remove nipple (56).
65. Remove elbow (26).
66. Remove reducer (66).
67. Remove nipple (67).
68. Install nipple (67).
69. Install reducer (66).
70. Install elbow (26).
71. Install nipple (56).
72. Install elbow (55).
73. Install coupling (54).
74. Install nipple (37).
75. Install elbow (38).
76. Install coupling (61).
77. Install hose (53).
78. Install elbow (65).
79. Install coupling (64).
80. Install hose (63).
81. Install coupling (62).
82. Install nipple (34).
83. Install elbow (33).

REMOVE/REPLACE

84. Install nipple (31).
85. Install elbow (29).
86. Install coupling (28).
87. Install hose (27)
88. Install hose (25).
89. Install coupling (60).
90. Install elbow (59).
91. Install pipe (58).
92. Install elbow (57).
93. Install pipe (51).
94. Install elbow (45).
95. Install coupling (44).
96. Install hose (43).
97. Install coupling (42).
98. Install pipe (32).
99. Install elbow (52).
100. Install pipe (50).
101. install elbow (49).
102. Install coupling (48).
103. Install reducer (47).
104. Install elbow (46).
105. Install pipe (36).
106. Install elbow (35).
107. Install bolts (41), washers (40) and bracket (39).
108. Install nuts and U-bolts (30).

4-58. REPLACE BATTERY ASSEMBLY

This Task Covers: a. Inspect b. Service c. Replacement

INITIAL SETUP**Tools Required**

Tool Kit, General Mechanics
(Appendix B, Item 1)

Materials/Parts Required

Cotton Rags (Appendix E, Item 3)

Equipment Conditions

Engine Shutdown (para 2-11).

Personnel Required

1 Person

INSPECT (Figure 4-48).

1. Inspect for loose bolts (8).
2. Inspect for loose cable connections (5).

SERVICE

1. Remove lids (3).
2. Add water flush with cell top.
3. Replace lids.

REPLACEMENT**CAUTION**

Remove negative cable first and install negative cable last.

1. Loosen connections (5).
2. Remove cables from batteries (2).
3. Remove batteries from battery box (1).
4. Loosen and remove nuts (9), lockwashers (7), bolts (8), and flat washers (6).
5. Remove battery box (1).

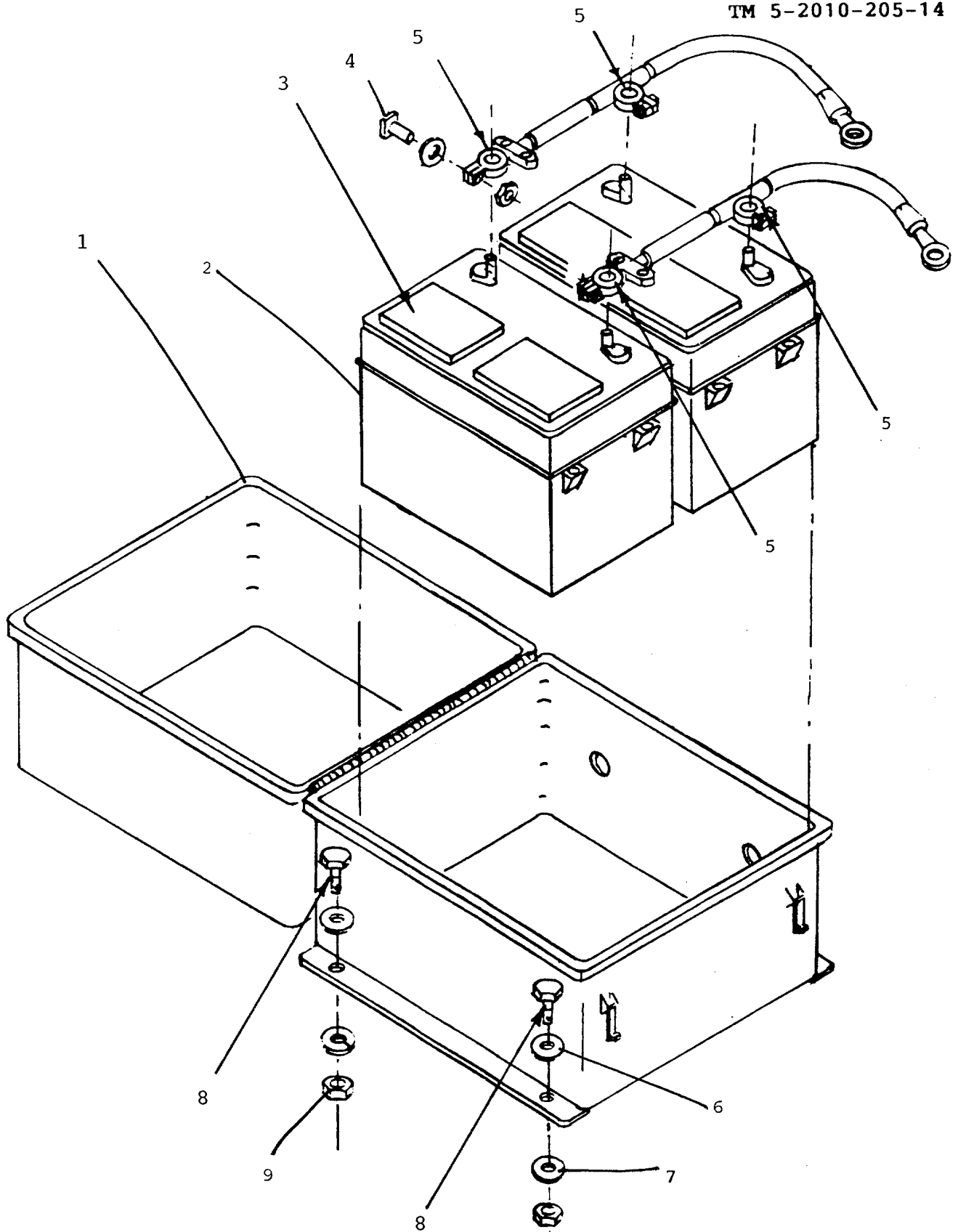

Figure 4-48. Battery Assembly
4-109

6. Install battery box (1).
7. Install flatwashers (6), bolts (8), lockwashers (7), nuts (9), and tighten.
8. Install batteries into battery box (1).
9. Install cables.
10. Tighten cable connections (5).

4-59. REPAIR/REPLACE SQUIRREL CAGE FAN ASSEMBLY

This Task Covers: a. Inspect b. Repair c. Replacement

INITIAL SETUP**Tools Required**

Tool Kit, General Mechanics
(Appendix B, Item 1)

Equipment Conditions.

Engine Shutdown (para 2-11).
Battery Disconnected (para 4-58).
Guard Assembly Removed
(para 4-48).

Materials/Parts Required

Cotton Rags (Appendix E,
Item 3)
Fan Belt P/N P08047
Squirrel Cage P/N 4C770
Pulley P/N P08046
Housing P/N 4C770

Personnel Required

2 Persons

INSPECT (Figure 4-49.)

1. Inspect for loose bolts.
2. Inspect for belt tension.

REPAIR Repair is limited to replacement of defective parts.

REPLACEMENT**CAUTION**

Excessive belt tension is the most frequent cause of bearing wear and resulting noise.

1. Loosen nuts (4).
2. Lift fan (3) enough to remove belt (2).
3. Remove fan (3).
4. Loosen setscrews (6).
5. Remove bolts (5).

6. Remove pulleys (1).
7. Install pulleys (1).
8. Install bolts (5).
9. Install setscrews (6).
10. Install fan.
11. Install belt.
12. Tighten nuts (4).

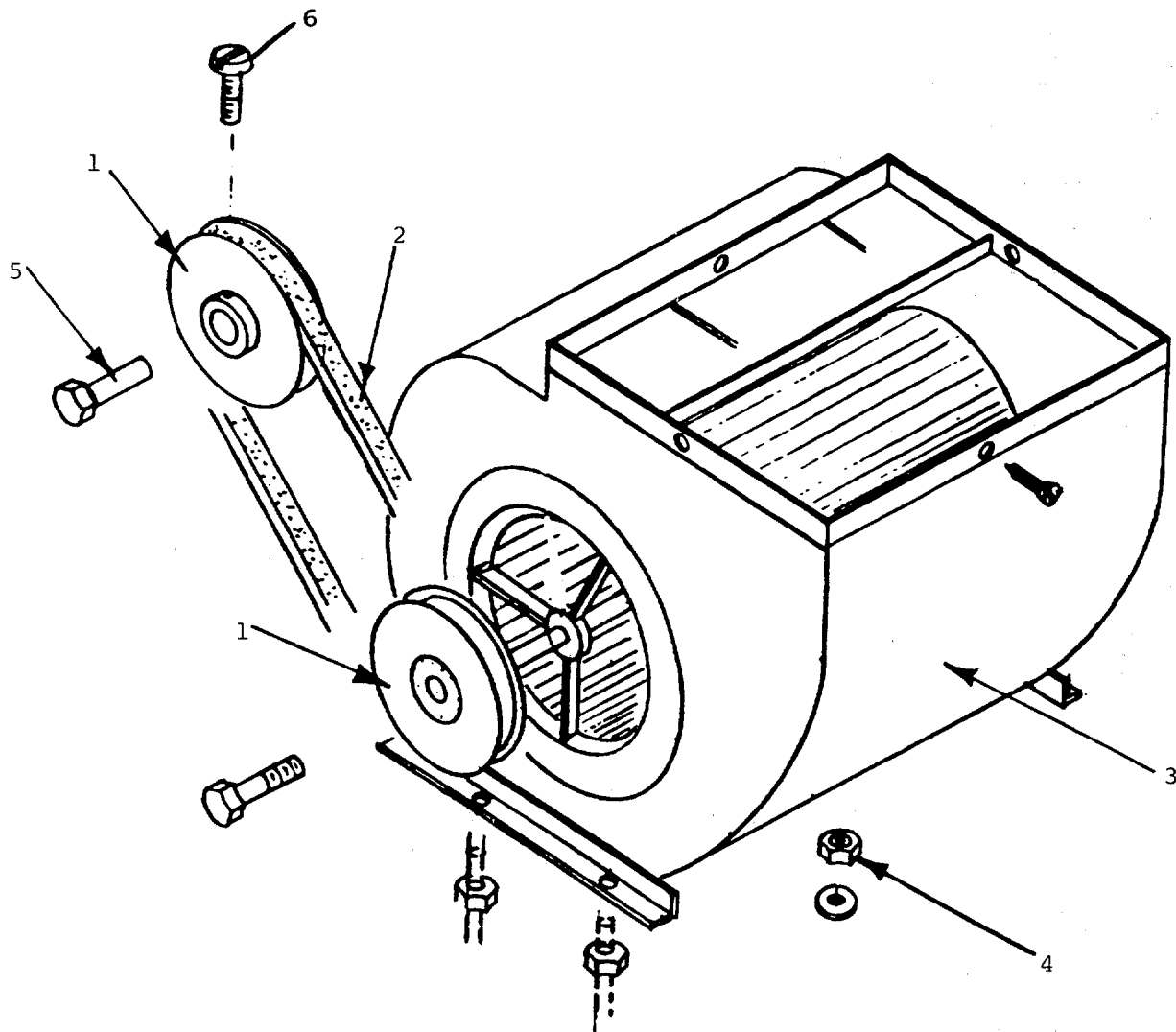

Figure 4-49. Squirrel Cage Fan Assembly

4-60. REPLACE HAND DRIVEN PUMP ASSEMBLY

This Task Covers: a. Inspect b. Replacement

INITIAL SETUPTools Required

Tool Kit, General Mechanics
(Appendix B, Item 1)

Equipment Conditions.

Engine Shutdown (para 2-11).
Battery Disconnected (para 4-53).
Close Hydraulic Valve
(LO 5-2010-205-12)

Materials/Parts Required

Cotton Rags (Appendix E,
Item 3)
Hand Driven Pump
Assembly P/N SP3A

Personnel Required

1 Person

INSPECT (Figure 4-50.)

1. Inspect for loose bolts.
2. Inspect for leaks.

REPLACEMENT

1. Disconnect hose connections (2, 3, 6 and 8).
2. Loosen and remove bolts (4) and washers (5).
3. Remove assembly (7).
4. Remove piping assembly (9).
5. Install piping assembly (9).
6. Install pump assembly (7).
7. Install bolts (4), washers (5), and tighten.
8. Tighten hose connections (2, 3, 6 and 8).

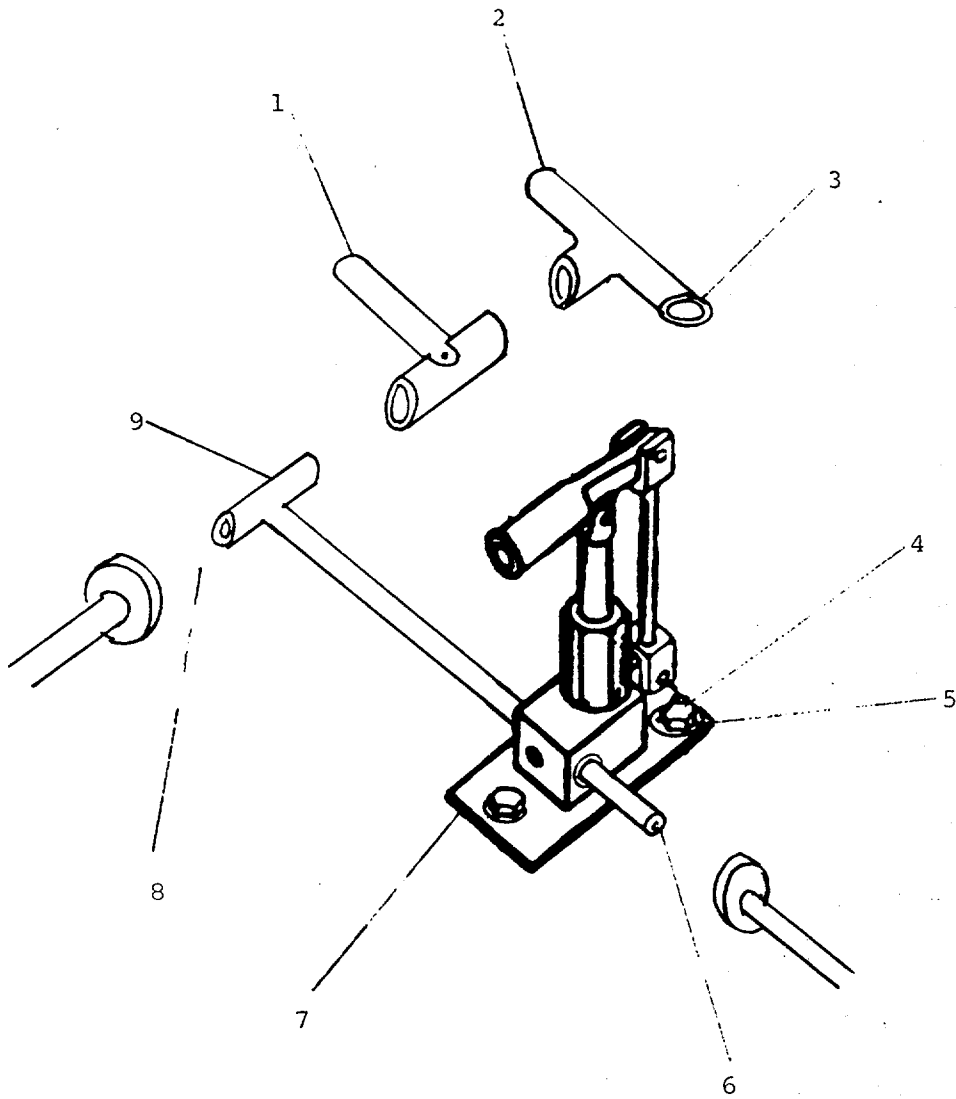

Figure 4-60. Hand Driven Pump Assembly

4-61. UPPER OUTDRIVE HOUSING ASSEMBLY

This Task Covers: a. Inspect b. Service

INITIAL SETUPTools Required

Tool Kit, General Mechanics
(Appendix B, Item 1)

Materials/Parts Required

Cotton Rags (Appendix E,
Item 3)

Equipment Conditions.

Engine Shutdown (para 2-11).
Battery Disconnected (para 4-58).

Personnel Required

1 Person

INSPECT

1. Remove bolts (1).
2. Remove cover (2).
3. Inspect for leaks.
4. Inspect for loose bolts.
5. Install cover.
6. Install and tighten bolts.

SERVICE

Refer to LO-5-2010-205-12.

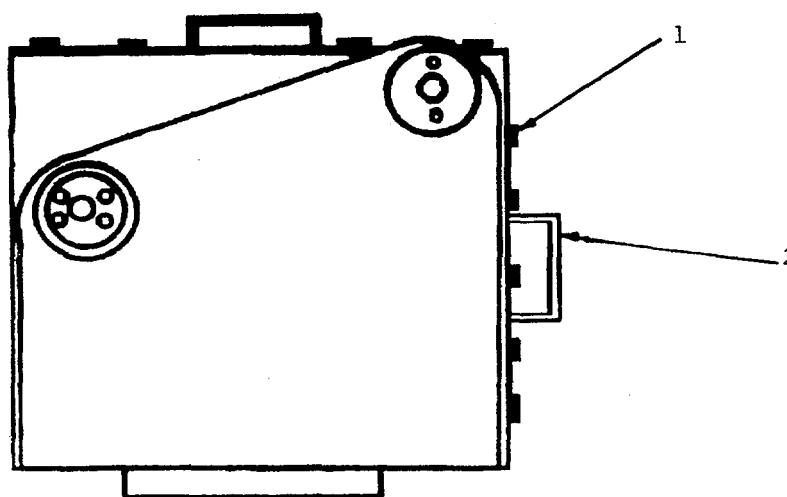

Figure 4-61. Outdrive Housing Assembly

4-62. REPLACE STEERING MOTOR ASSEMBLY

This Task Covers: a. Inspect b. Replacement

INITIAL SETUPTools Required

Tool Kit, General Mechanics
(Appendix B, Item 1)

Equipment Conditions.

Engine Shutdown (para 2-11).
Battery Disconnected (para 4-58).
Upper Housing Cover Removed
(para 4-61).
Close Hydraulic Valve
(LO 5-2010-205-12)

Materials/Parts Required

Cotton Rags (Appendix E,
Item 3)
Steering Motor
Assembly P/N RE240804

Personnel Required

1 Person

INSPECT (Figure 4-62.)

1. Inspect for loose bolts.
2. Inspect hose connections for leaks.

REPLACEMENT

1. Disconnect hoses at (1).
2. Loosen and remove bolts (2) and washers (3).
3. Remove motor (4).
4. Remove key (5).
5. Install new key (5).
6. Install motor (4).
7. Install and tighten bolts (2) and washers (3).
8. Connect hoses at (1).

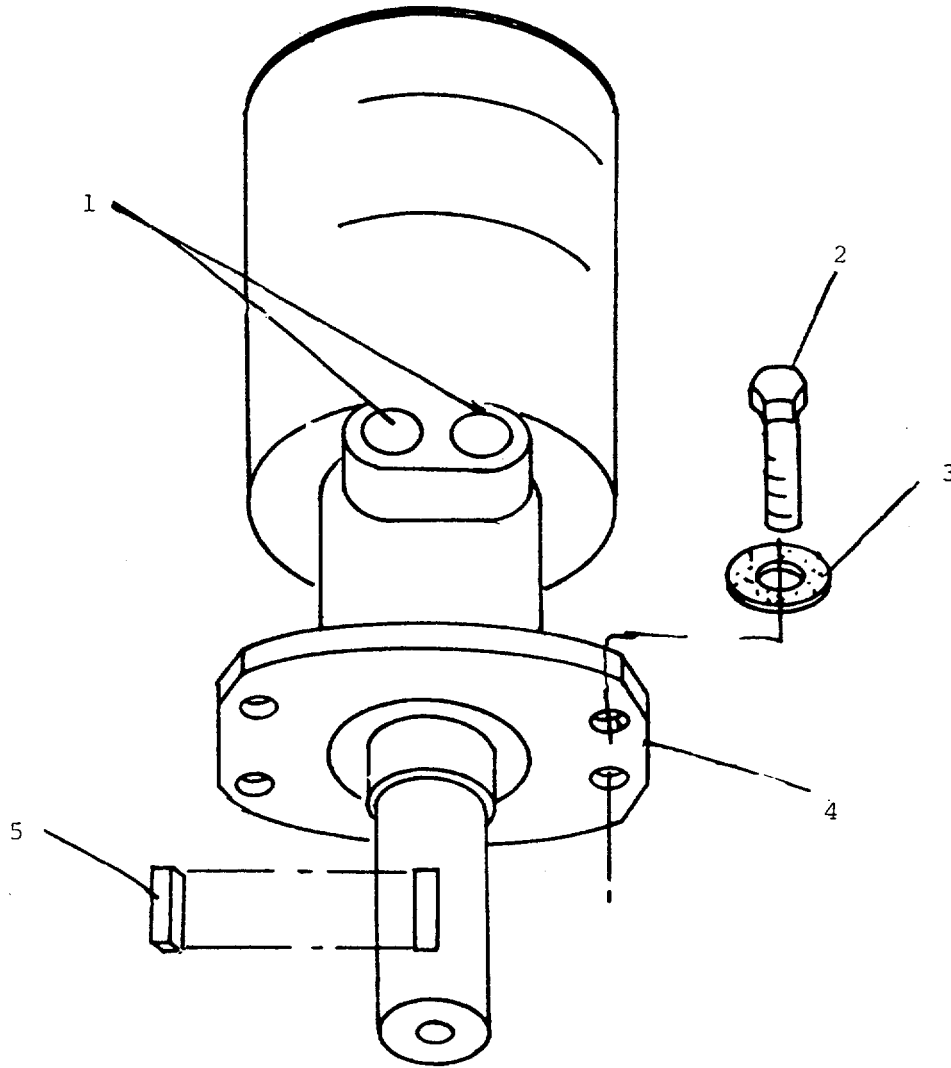

Figure 4-62. Steering Motor Assembly

4-63. REPAIR/REPLACE DIRECTION INDICATOR ASSEMBLY

This Task Covers: a. Inspect b. Adjust c. Repair d. Replacement

INITIAL SETUPTools Required

Tool Kits, General Mechanics
(Appendix B, Item 1)

Equipment Conditions

Engine Shutdown (para 2-11).
Battery Disconnected (para 4-58).
Upper Housing Cover Removed
(para 4-61).

Materials/Parts Required

Key P/N P06002
Cotton Rags (Appendix E,
Item 3)
Chain P/N P08042
Transmitter P/N P04130
Sprocket P/N P08041
Sprocket P/N P08040

Personnel Required

1 Person

INSPECT (Figure 4-63.)

1. Inspect for loose bolts (4).
2. Inspect for loose chain (14).
3. Inspect for loose electrical connections (9).

ADJUST

1. Loose bolts (4).
2. Slide transmitter (8) to tighten chain (14).
3. Tighten bolts (4).

REPAIR Repair is limited to replacement of defective parts.

REPLACEMENT

1. Loosen bolts (4).
2. Remove chain (14).

3. Remove sprocket (3).
4. Remove key (5).
5. Remove electric wire (9).
6. Remove bolts (4), washers (6), and nuts (7).
7. Remove transmitter (8).
8. Loosen and remove nut (1) and washer (13) from stud (10).
9. Remove sprocket (12).
10. Install sprocket (12).
11. Install washer (13) and nut (1).
12. Install transmitter (8).
13. Install bolts (4), washers (6), and nuts (7).

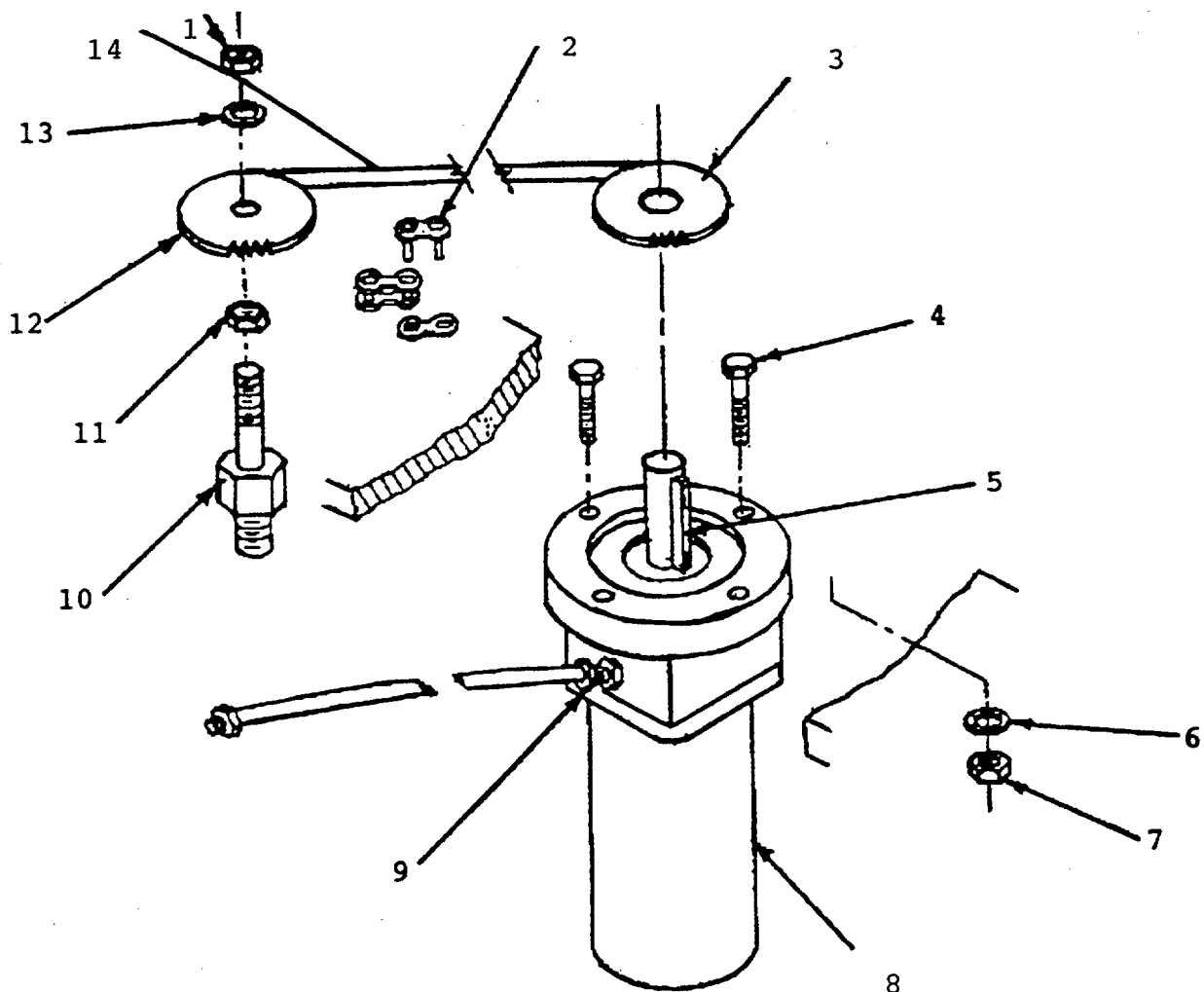

Figure 4-63. Direction Indicator Assembly
4-119

NOTE

Do not tighten nuts (7) until chain (14) is installed and tension adjusted.

14. Install electric wire (9).
15. Install key (5).
16. Install sprocket (3).
17. Install chain (14).

NOTE

Adjust tightness of chain (14) by sliding transmitter (3) until there is about 1/4 inch of side-ways movement of chain.

18. Tighten nuts (7).

4-64. LOWER UNIT ASSEMBLY

This Task Covers: a. Inspect

INITIAL SETUPTools RequiredTool Kit, General Mechanics
(Appendix B, Item 1)Materials/Parts RequiredCotton Rags (Appendix E,
Item 3)Equipment ConditionsEngine Shutdown (para 2-11).
Battery Disconnected (para 4-58).Personnel Required1 Person

INSPECTWARNING

Place a warning tag on the control panel indicating the unit is out of service before inspecting.

1. Inspect for loose screws (2) and bolts (3).
2. Inspect for loose nut (6), and locknut (7).
3. Inspect for leaks at (4) and (5).
4. Inspect propeller (1) for damage

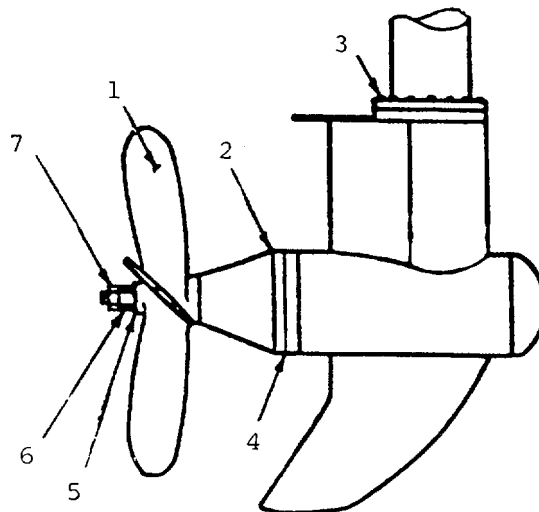

Figure 4-64. Lower Unit Assembly
4-121

4-65. LIFT CYLINDER ASSEMBLY

This Task Covers: a. Inspect

INITIAL SETUPTools RequiredTool Kit, General Mechanics
(Appendix B, Item 1)Materials/Parts RequiredCotton Rags (Appendix E,
Item 3)Equipment ConditionsEngine Shutdown (para 2-11).
Battery Disconnected (para 4-58).Personnel Required1 Person

INSPECT

1. Inspect for leaks at hose connections (1).
2. Inspect for loose bolts at clevis connections (2).
3. Inspect for leaks at piston rod (3).
4. Inspect for obvious damage.

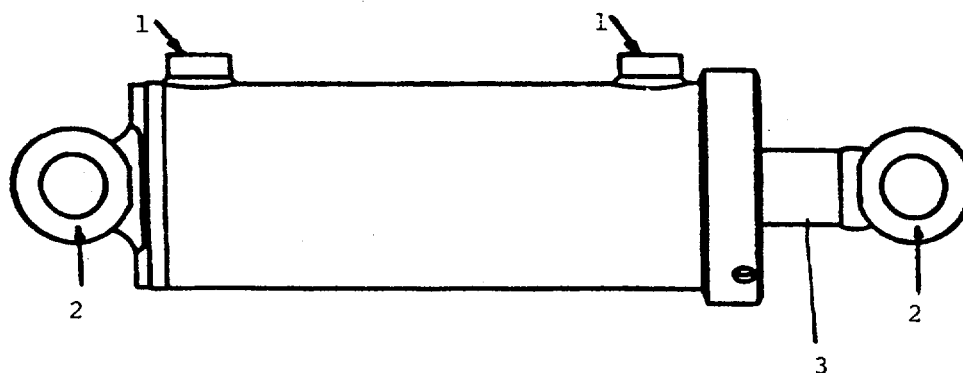

Figure 4-15. Lift Cylinder Assembly

4-66. REPLACE ELECTRICAL ASSEMBLY

This Task Covers: a. Inspect b. Replacement

INITIAL SETUP**Tools Required**

Tool Kit, General Mechanics
(Appendix B, Item 1)

Materials/Parts Required

Cotton Rags (Appendix E,
Item 3)
Cable P/N TMOT-10

Equipment Conditions

Engine Shutdown (para 2-11).
Battery Disconnected (para 4-58).

Personnel Required

1 Person

INSPECT (Figure 4-66.)

1. Inspect for loose screws (4) on couplings (6).
2. Inspect for loose nut (3).

REPLACEMENT

1. Disconnect cable (2) at connection (1).
2. Disconnect cable (2) at connection (3).
3. Loosen and remove screw (4), washers (5) from plug (6).
4. Remove plug (6).
5. Install plug (6).
6. Install and tighten washer (5) and screw (4).
7. Connect cable (2) at connection (3).
8. Connect cable (2) at connection (1).

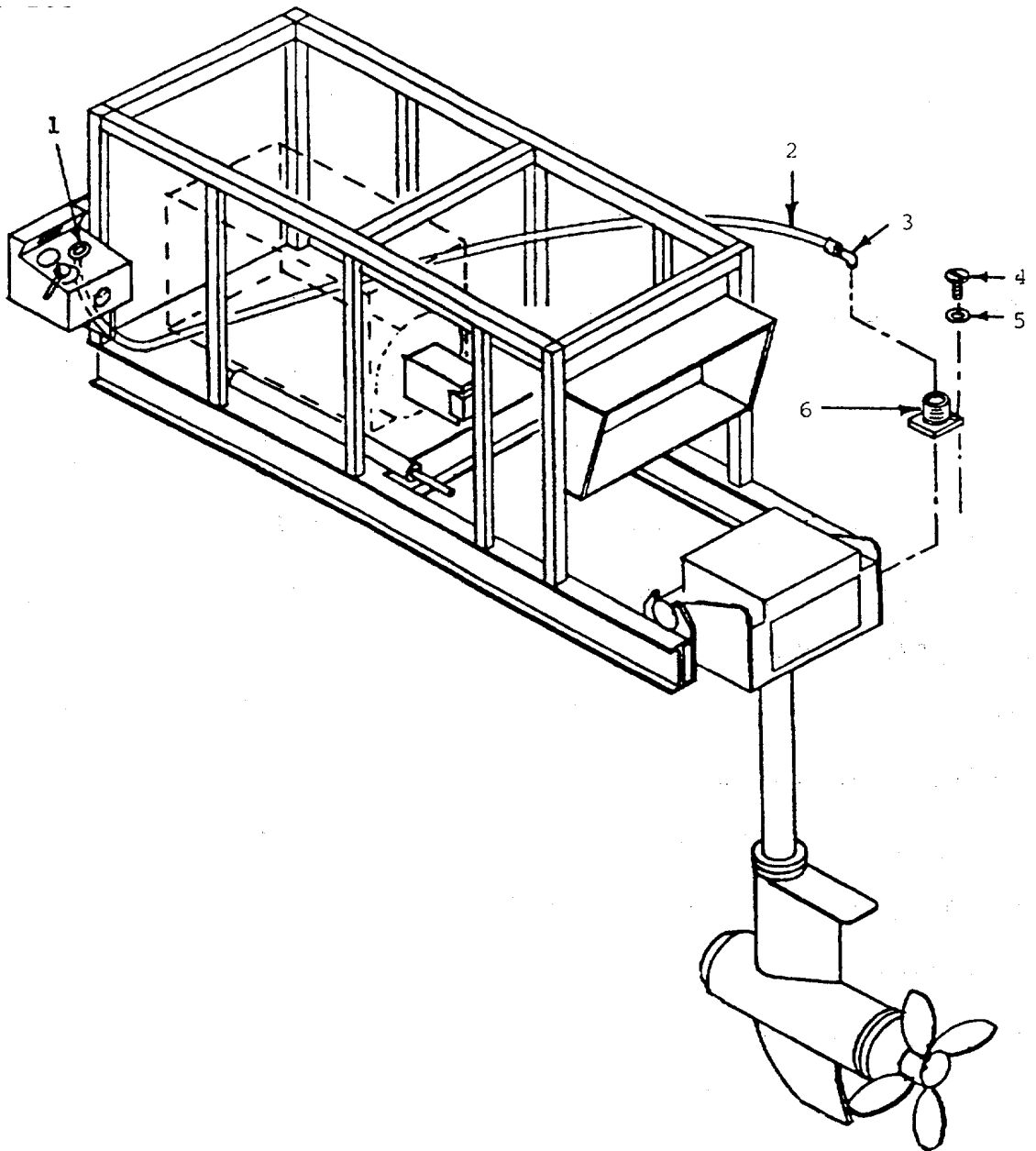

Figure 4-66. Connecting Electrical Assembly

4-67. REPLACE CONNECTING HYDRAULIC HOSE ASSEMBLY

This Task Covers: a. Inspect b. Replacement

INITIAL SETUP

Tools Required

Tool Kit, General Mechanics
(Appendix B, Item 1)

Equipment Conditions

Engine Shutdown (para 2-11).
Battery Disconnected (para 4-58).
Close Hydraulic Valve
(LO 5-2010-205-12)

Materials/Parts Required

Cotton Rags (Appendix E,
Item 3)
Masking Tape (Appendix E,
Item 8)
Hydraulic Hose Assembly
Hose P/N N6ER2024PH4520PH-70
Hose P/N E7HU1212NJ16NJ-74
Hose P/N J4HIJ0808NJ08RC-180
Hose P/N J4HU0808RC12NJ-180

Personnel Required

1 Person

INSPECT (Figure 4-67.)

- 1. Inspect for loose hose connections.
- 2. Inspect for damage to hoses.
- 3. Inspect for leaks.

REPLACEMENT

NOTE

Clean connection and area around connection before disconnecting any hoses.

NOTE

Hose ends and fittings should be covered as soon as they are disassembled.

- 1. Loosen connections (17) and (7).

REPLACEMENT

2. Remove hose (1).
3. Loosen connections (18) and (6).
4. Remove hose (3).
5. Loosen connections (2) and (5).
6. Remove hose (4).
7. Loosen connections (8) and (16).
8. Remove hose (11).
9. Loosen connections (9) and (15).
10. Remove hose (12).
11. Loosen connections (10) and (14).
12. Remove hose (13).
13. Install hose (13).
14. Tighten connections (10) and (14).
15. Install hose (12).
16. Tighten connections (9) and (15).
17. Install hose (11).
18. Tighten connections (8) and (16).
19. Install hose (4).
20. Tighten connections (2) and (5).
21. Install hose (3).
22. Tighten connections (18) and (6).
23. Install hose (1).
24. Tighten connections (17) and (7).

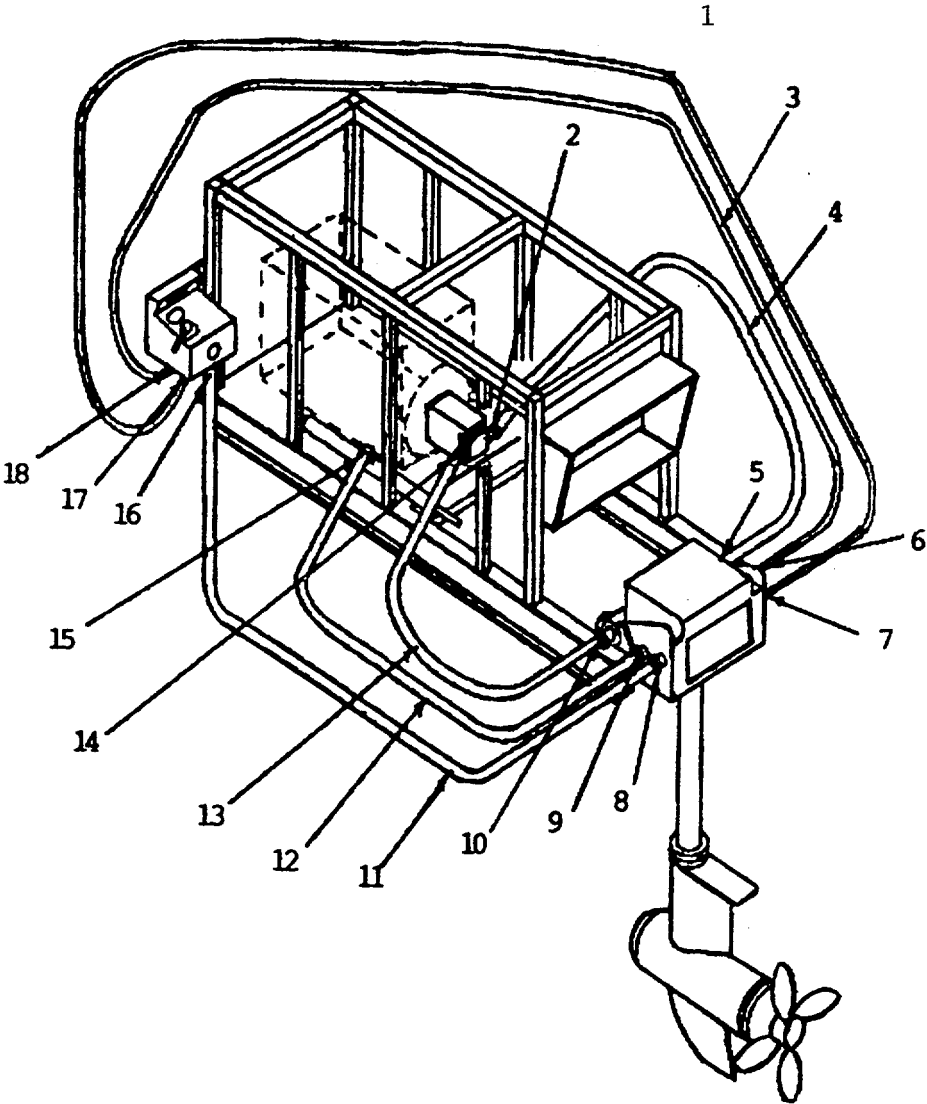

Figure 4-67. Connecting Hydraulic Hose Assembly

Section VI. PREPARATION FOR STORAGE OR SHIPMENT

4-68. GENERAL. If the propelling unit will be out of service for an extended period of time (3 weeks or longer), or reshipped to another location, certain actions must be taken to protect it against the corrosive effect of the elements. Further information can be found in Army Technical Bulletin TB 740-97-4.

a. Temporary Storage. If an engine is to remain out of service for a maximum of 6 months, the procedures listed below are required to minimize or prevent damage:

(1) Start the engine and operate until thoroughly warm. Shut engine down. Disconnect the fuel lines to the engine fuel filter and injector drain line (fuel return to tank). Fill two containers, one with diesel fuel and a second with preservative oil (MIL-L-644 Type P-9).

(2) Start the engine with the fuel line to the filter submerged in the container of diesel fuel. (The injector drain line should also flow into the container.) After the engine is running smoothly, switch the fuel line to the container with the preservative oil. Operate the engine for 5 to 10 minutes on preservative oil. Stop the engine and reconnect the fuel lines.

(3) Drain the oil sump and fuel filters and reinstall the drain plugs. The sump may remain empty until the engine is ready for use; tag the engine with a warning tag.

(4) Disconnect the electrical wiring. Spray lubricating oil into the intake manifold while cranking the engine slowly.

(5) Cover all the openings with tape to prevent the entrance of dirt and moisture.

(6) Bar the engine crankshaft two or three revolutions each three to four weeks.

b. Permanent Storage. When an engine is to be stored 6 months or more, the following procedures must be performed:

(1) Start the engine and operate it at fast idle until the engine is thoroughly warm. Stop the engine and drain the old oil.

(2) Fill the crankcase to the full mark on the dipstick with preservative oil, U.S. Military Specification MIL-L-21260, Type P-10, Grade 2 SAE 30.

(3) Repeat steps a, (1), (2), and (3) above.

(4) Disconnect the electrical wiring.

(5) Remove the intake and exhaust manifolds. Spray all the intake and exhaust ports with preservative oil. Replace the manifolds.

(6) Inspect the cooling system; if the coolant is contaminated, drain it and flush the system. Fill it with a rust preventive compound.

(7) Remove the exhaust plate from the starter and spray with preservative oil. Reinstall plate.

(8) Brush or spray a film of rust preventive compound on all exposed, unpainted surfaces of the engine. Use a rust preventive conforming to Type P-1, Grade 1 or 2, U.S. Military Specification MIL-C-16173C. Remove springs, guides, crosshead and push tubes. Replace the covers.

(9) Cover all the engine openings with heavy paper and tape. Tag the engine to indicate that it has been treated with preservatives and the crankshaft should not be barred over. The tag should indicate: if coolant has been removed, the date of treatment, and that the engine is not ready to run.

(10) Store the engine in an area where the air is dry and temperature uniform.

NOTE

Engines in storage for more than 24 months should be flushed out with a suitable solvent or a light, hot oil, and then be reprocessed with rust preventive materials. Periodically inspect the engines for rust or corrosion. Take corrective action as necessary.

Although the preservative materials may be added to and be used for the same purpose repeatedly, they must be kept clean; the accumulated deposits should be removed after being allowed to settle.

4-69. PREPARING A STORED ENGINE FOR SERVICE. When an engine is removed from storage and put into service, the following operations must be performed:

a. Clean Engine.

(1) Clean accumulated dirt from the exterior of the engine. Remove the covers, tape, and wrappings.

(2) Use a suitable cleaner to remove the rust preventive compound from the unpainted surfaces.

(3) If required, paint the engine in accordance with TM 43-0139, Painting Instructions for Field Use.

(4) Refill the crankcase with clean lubricating oil. Flush and fill the cooling system. Install DCS (Diesel Coolant Additives) precharge elements to the water filter heads. These will be exchanged with service elements at the first oil change.

b. Inspection.

(1) When an engine has been stored for 6 months or less, it is necessary to adjust the injectors and valves, tighten the cylinder head capscrews and connections, and replace the filters.

(2) When an engine has been stored for 6 months or more, the following procedures must be followed in addition to the above:

(a) Flush the fuel system with clean fuel oil until all preservative oil is removed.

(b) Remove a plug from the oil gallery and force hot, light mineral oil through the oil passages to flush away all preservative oil. Bar over the engine crankshaft three or four revolutions during the flushing operation.

(c) Actions stated in paragraph b. (1) above.

(d) After inspecting the engine and parts, make sure all the preservative oil and accumulated deposits have been flushed away. Start the engine as described in paragraph 2-5(b) and (c).

CHAPTER 5

DIRECT SUPPORT MAINTENANCE

		<u>Page</u>
Section I	Repair Parts, Special Tools, TMDE, and Support Equipment	5-1
Section II	Maintenance of Engine and Propelling Unit	5-2
Section III	Preparation for Shipment or Storage	5-87

Section I. REPAIR PARTS, SPECIAL TOOLS, TMDE, AND SUPPORT EQUIPMENT

5-1. COMMON TOOLS AND EQUIPMENT. For authorized common tools and equipment, refer to the Maintenance Allocation Chart.

5-2. SPECIAL TOOLS, TMDE, AND SUPPORT EQUIPMENT. Refer to the Repair Parts and Special Tools list (TM 5-2010-205-24P) and to the Maintenance Allocation Chart (Appendix B of this manual) for the special tools, TMDE, and support equipment required.

5-3. REPAIR PARTS. Repair parts are listed and illustrated in the Repair Parts and Special Tools List (TM 5-2010-205-24P) covering Direct Support Maintenance for this equipment.

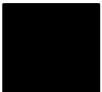

Section II. DIRECT SUPPORT MAINTENANCE PROCEDURES

5-4. REPAIR PROPELLING UNIT

This Task Covers: a. Test b. Adjust c. Repair

INITIAL SETUPTools Required

Tool Kit, General Mechanics
(Appendix B, Item 1)

Equipment Conditions

Engine Shutdown (para 2-11).
Battery Disconnected (para 4-58).

Materials/Parts Required

Cotton Rags (Appendix E,
Item 3)
Top Cover P/N D100314
Transmitter Chain P/N P08042
Propeller P/N D100410
Wheel P/N SW32166
Handle P/N B100431

Personnel Required

1 Person

TEST (Figure 5-1)

1. While turning wheel (5), observe steering motion of propeller (3) and check that indicator (1) is tracking.
2. Engage forward/aft thrust handle (6) to forward and then to aft. Observe for smooth reversal of propeller (4) rotation.

ADJUST

1. Remove top cover (2) of Upper Outdrive Assembly.
2. Remove transmitter chain (4) (para 4-63).
3. Set pointer on control panel position indicator (1) to zero degrees.
4. Rotate Lower Unit Assembly until propeller (3) is positioned as shown (directly AFT).
5. Reinstall chain (4) (para 4-63) and cover (2).

REPAIR Repair is limited to replacement of defective parts.

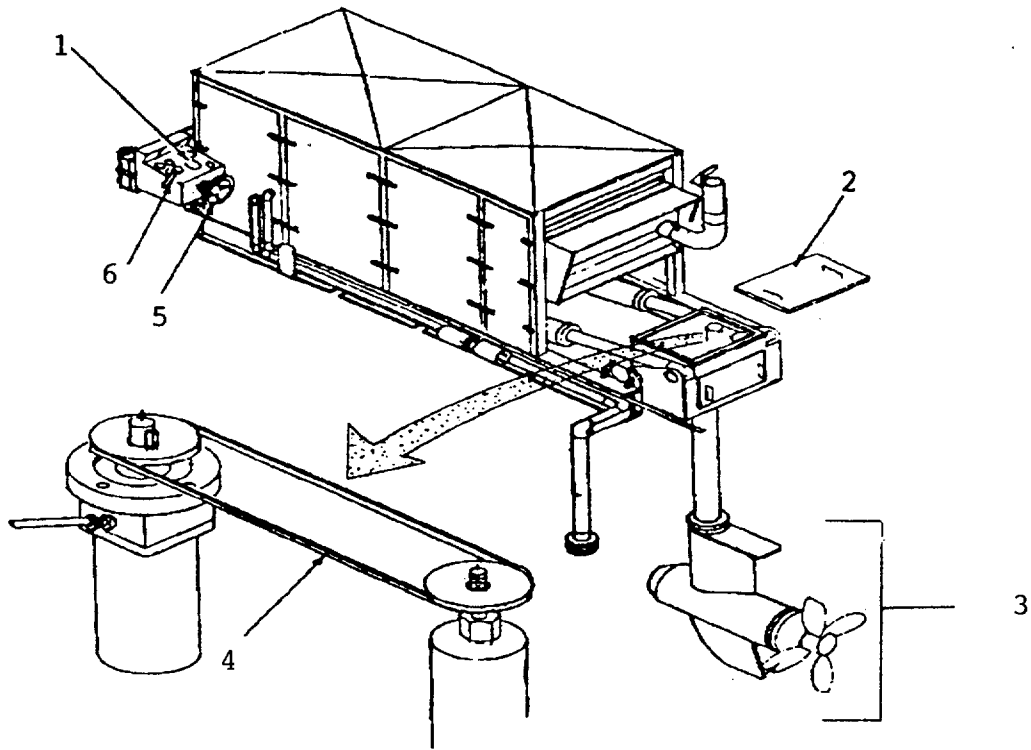

Figure 5-1. Propelling Unit

5-5. REPAIR/REPLACE FRAMEWORK ASSEMBLY

This Task Covers: a. Repair b. Replacement

INITIAL SETUP

Tools Required

Tool Kit, General Mechanics
(Appendix B, Item 1)

Equipment Conditions

Engine Shutdown (para 2-11).
Battery Disconnected (para 4-58).

Materials Parts Required

- Cotton Rags (Appendix E,
Item 3)
- Roof P/N C100412
- Roof P/N C100388
- Roof P/N C100387
- Roof P/N C100392
- Screw P/N P07154
- Screw P/N MS90728-62
- Door P/N C100389
- Door P/N C100394
- Door P/N C100393
- Door P/N D100444
- Screw P/N MS90728-111
- Washer P/N MS51412-10
- Nut P/N MS25082-19
- Bolt P/N MS90728-32
- Washer P/N MS51412-5
- Bumper Strip P/N 3MD-1
- Louver Vent P/N LAG129
- Screw P/N MS90728-189
- Washer P/N P07013
- Screw P/N MS90728-170
- Nut P/N MS25082-10
- Washer P/N P07020
- Gasket P/N P05032
- Bolt P/N P07155
- Washer P/N MS51416-2

Personnel Required

1 Person

REPAIR

Repair is limited to replacement of defective parts.

REPLACEMENT

(Figure 5-2.)

1. Remove bolts (6) typical.
2. Remove doors (7, 8, 9, and 10).
3. Remove bolts (5).
4. Remove louver vent (4).
5. Remove screws (2).
6. Remove top sections (1) and (3).
7. Install top sections (1) and (3).
8. Install screws (2).
9. Install louver vent (4).
10. Install bolts (5).
11. Install doors (7, 8, 9, and 10).
12. Install bolts (6).

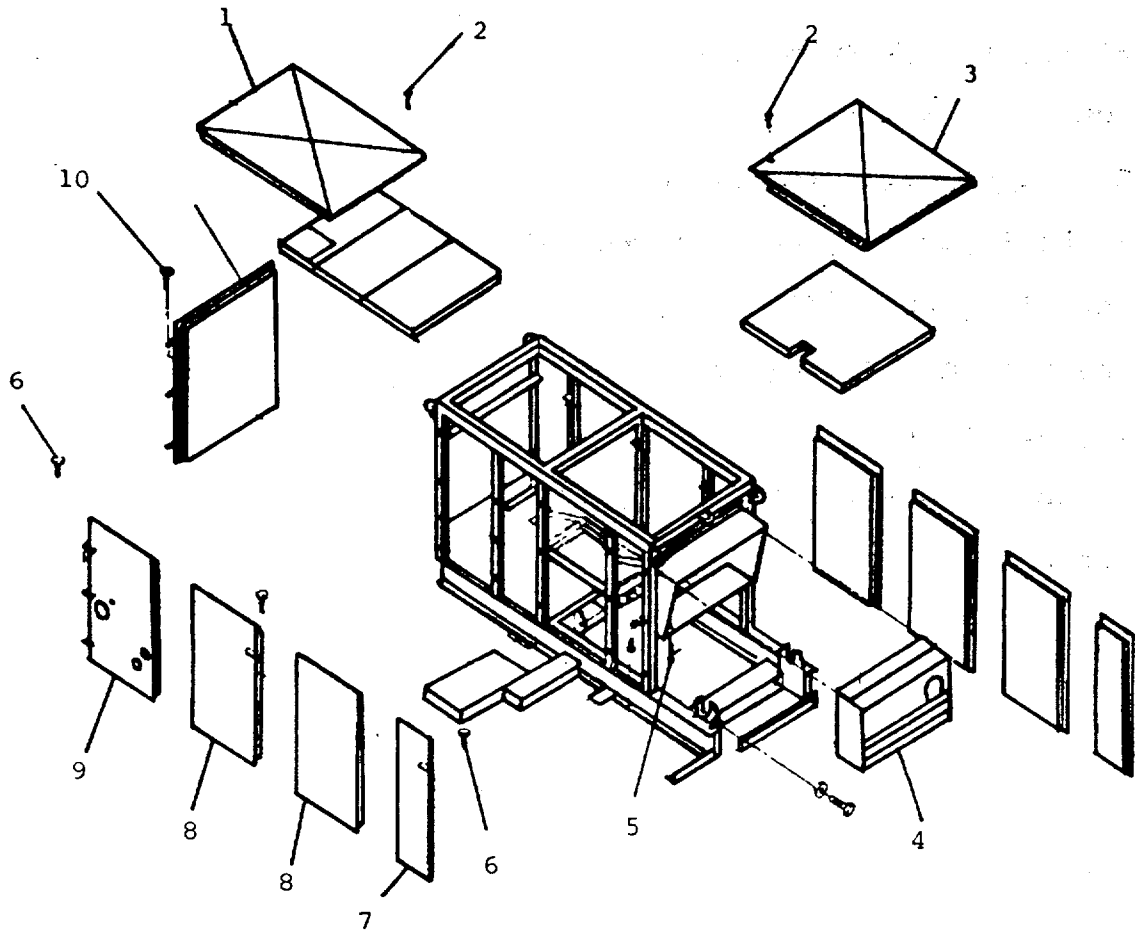

Figure 5-2. Framework Assembly

5-6. REPAIR/REPLACE ENGINE ASSEMBLY.

This Task Covers: a. Test b. Adjust c. Repair d. Replacement

INITIAL SETUPTools Required

Tool Kit, General Mechanics
(Appendix B, Item 1)
Tool Kit, Automotive
(Appendix B, Item 3)
Hoist

Equipment Conditions

Engine Shutdown (para 2-11).
Battery Disconnected (para 4-58).
Doors and Top Cover Removed
(para 5-5).

Materials/Parts Required

Engine P/N PA0520

Personnel Required

2 Persons

TEST

1. Throttle down prior to cranking.
2. Crank and run engine at cranking speed (about 1000 rpm) until oil pressure is observed.
3. Operate engine for ten minutes at low idle (about 1300 rpm).
4. Observe oil pressure and water temperature gauges for normal operating ranges.
5. Operate engine at 3/4 rated speed (about 1800 rpm) for 15 minutes monitoring the appropriate engine gauges.
6. Throttle to 2400 rpm and observe all gauges. If there are any indications of operating above gauge limits (or other signs of trouble) shut-down immediately and refer to the "Troubleshooting" Section in this manual.

ADJUST (Figure 5-3) Adjustment of the engine is done by performing maintenance procedures on the individual component subassemblies. Refer to the appropriate chapter and section for maintenance procedures.

REPAIR

Repair is limited to replacement of defective parts.

REPLACEMENT

1. Remove hydraulic pump assembly (para 5-25).
2. Disconnect fuel lines (9) and (10).
3. Disconnect ground wire (11).
4. Loosen connection of exhaust assembly (4) at turbocharger (7).
5. Disconnect hoses from seawater pump (6).
6. Disconnect battery cables (para 4-58).
7. Loosen and remove engine support bolts (5).
8. Sling engine at lifting lugs (8) and lift from framework.
9. Lower engine into framework.
10. Install and tighten support bolts (5).
11. Connect battery cables.
12. Connect seawater pump hoses.
13. Connect exhaust system to turbocharger (4).
14. Connect ground wire (11).
15. Install hydraulic pump assembly.

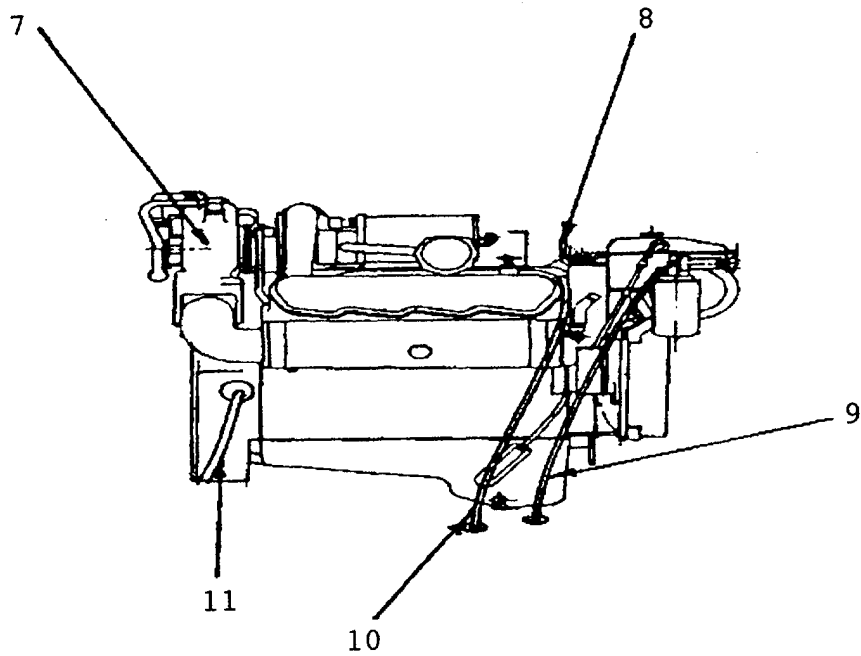
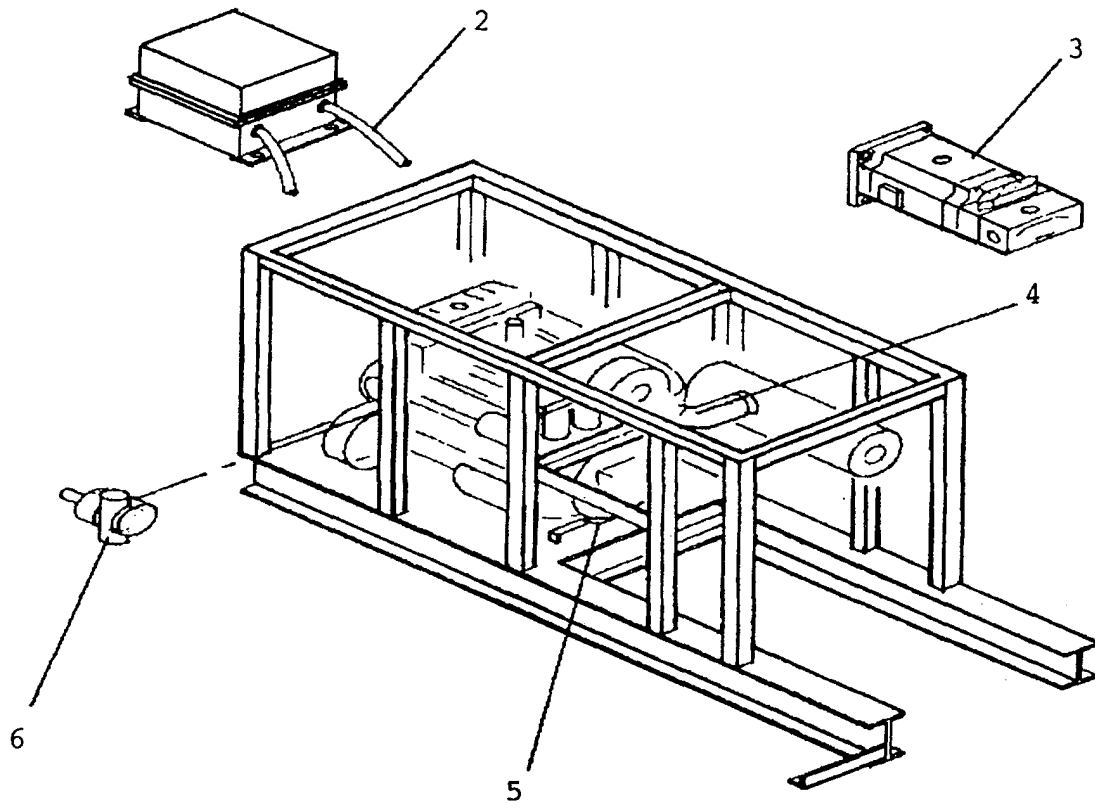

Figure 5-3. Engine and Framework Assembly

5-7. REPAIR COOLER ASSEMBLY

This Task Covers: a. Repair

INITIAL SETUPTools Required

Tool Kit, General Mechanics
(Appendix B, Item 1)
Shop Equipment (Appendix B,
Item 2)

Equipment Conditions

Engine Shutdown (para 2-11).
Battery Disconnected (para 4-58).
Oil Drained (LO5-2010-205-12).
Cooler Assembly Removed
(para 4-13).

Materials/Parts Required

Cotton Rags (Appendix E,
Item 3)
O-Ring P/N 2M9780
Seal P/N 2S4078
Seal P/N 4W7147
Gasket P/N 9N3354
Gasket P/N 9N2281

Personnel Required1 Person

REPAIR (Figure 5-4.)

1. Remove bolts (1) that hold cover (2) to base of oil cooler.
2. Remove cover (2) and core (3) from base of oil cooler.
3. Remove gasket (4) and (5) from cover (2) and core (3).
4. Remove cap (6), spring (7) and bypass valve (8) from base.

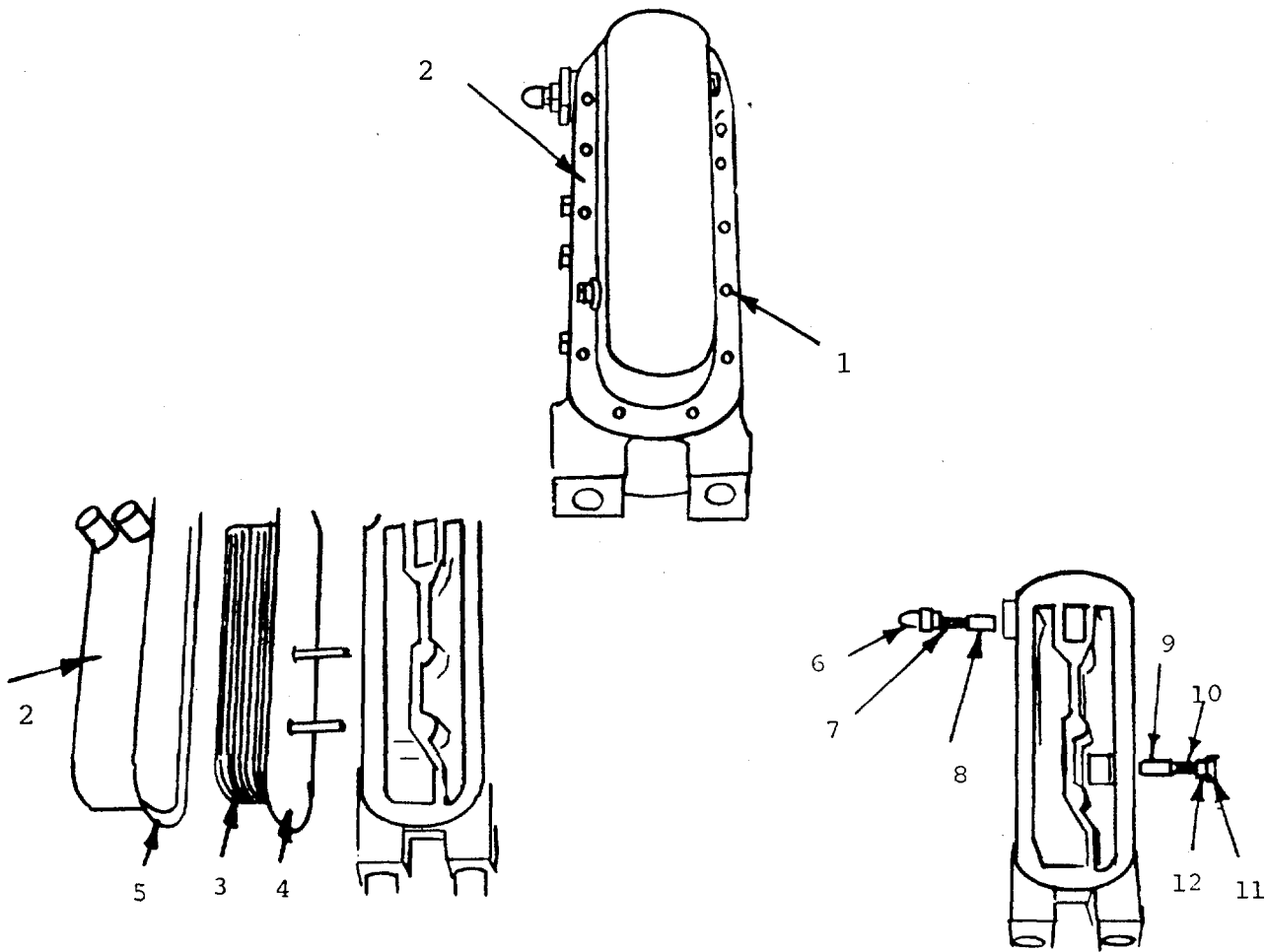

Figure 5-4. Cooler Assembly

5. Remove plug (11), spring (10) and bypass valve (9) from base.
6. Remove O-ring seal (12) from plug (11).
7. Install new O-ring seal on plug (11).
8. Install bypass valve (9), spring (10) and plug (11) in base.
9. Install bypass valve (8), spring (7) and cap (6) assembly in base.
10. Tighten cap (6) to a torque of 15 (+/1) 4 lb-ft.
11. Install core (3) in base.
12. Install gasket (4) on base with the index pointing toward the front of the engine and in the up position.
13. Install gasket (5) on cover (2).
14. Install cover (2) on base.
15. Tighten bolts (2).

5-8. REPAIR OIL PUMP ASSEMBLY

This Task Covers: a. Repair

INITIAL SETUPTools Required

Tool Kit, General Mechanics
(Appendix B, Item 1)
Drive Assembly
(Appendix B, Item 14)

Equipment Conditions

Engine Shutdown (para 2-11).
Battery Disconnected (para 4-58).
Oil Pan Removed (para 5-12).

Materials/Parts Required

Cotton Rags (Appendix E,
Item 3)
Oil Pump Assembly P/N 1N4254
Bolt P/N 051618
Bolt P/N 1D4539
Plunger P/N 1N3165
Spring P/N 1W1788
Guide P/N 7W0239
Seal P/N 8L2746
Gear P/N 9N5569
Bearing P/N 9N5572
Pan P/N 4N4475
Packing P/N 3K0360
Plug P/N 9S4185
Gasket P/N 9L8016
Bolt P/N 9L9178

Personnel Required

1 Person

REPAIR (Figure 5-5)

1. Remove bell assembly (1).
2. Remove bolts (3).
3. Remove cover (2).
4. Remove plunger and spring assembly (5).
5. Remove relief valve (4).
6. Remove inner rotor (8).
7. Remove outer rotor (7).
8. Measure the inside diameter of bearing (6).

NOTE

The inside diameter of bearing (6) must be 2.804 (+/- .002).

NOTE

If a replacement bearing (6) is needed, mark timing gear cover as to the location of the joint in the bearing.

9. Remove bearing (6).

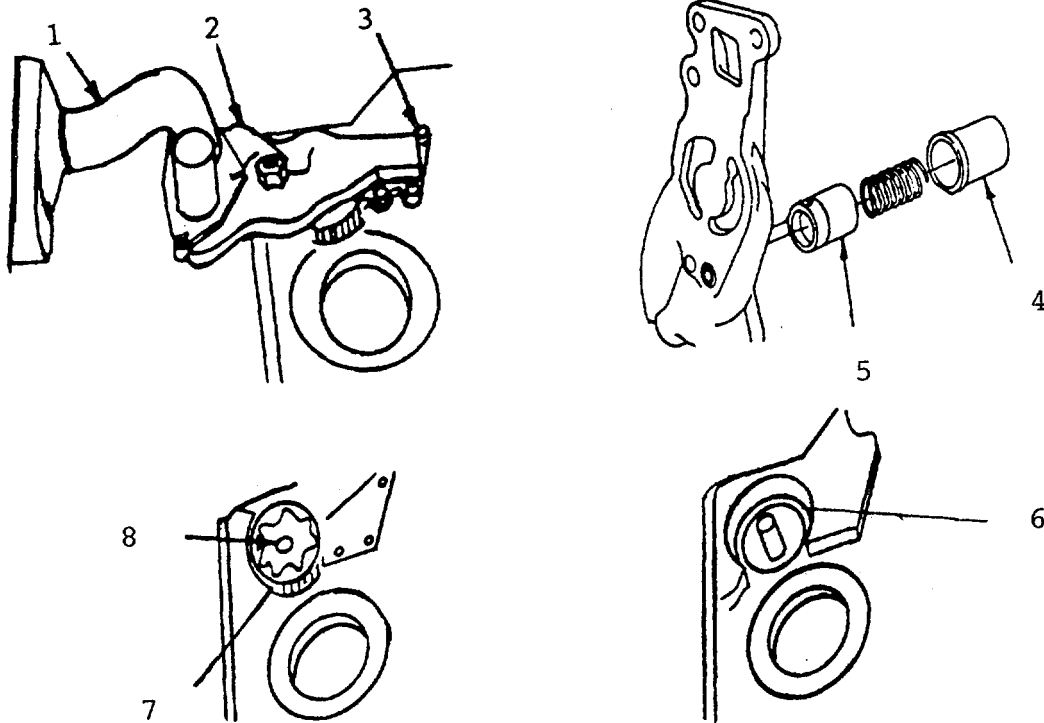

Figure 5-5. Oil Pump Assembly

10. Install bearing (6).
11. Install outer rotor (7).
12. Install inner rotor (8).

NOTE

Measure clearance between the rotor.
Clearance must be .002 to .006 inch.

NOTE

Both rotors must be replaced if only one is found defective.

13. Install relief valve (4).
14. Install plunger and spring assembly (5).

15. Install cover (2).
16. Install bolts (3).

17. Install bell assembly (1).

5-9. REPAIR/REPLACE TURBOCHARGER ASSEMBLY

This Task Covers: a. Repair b. Replacement

INITIAL SETUP
Tools Required

Tool Kit, General Mechanics
 (Appendix B, Item 1)
 Turbo Fixture Group
 (Appendix B, Item 8)
 Fixture Assembly
 (Appendix B, Item 15)

Materials/Parts Required

Cotton Rags (Appendix E,
 Item 3)
 Gasket P/N 7M7273
 Cartridge P/N 4N6701
 Turbocharger Assembly
 P/N 6N0580

Equipment Conditions

Engine Shutdown (para 2-11).
 Battery Disconnected (para 4-58).
 Air Intake Filter Removed
 (para 4-49).
 Turbo Lines Removed (para 4-35).
 Air Lines Removed (para 4-31).

Personnel Required

2 Persons

REPAIR Repair is limited to the replacement of defective parts.

REPLACEMENT (Figure 5-6.)

1. Loosen and remove nuts and washers (2).
2. Remove turbocharger assembly (1).
3. Remove gasket (3).
4. Install turbocharger assembly in holding device.

NOTE

Put marks on the three housings (7, 5, and 1) prior to disassembly to insure proper alignment at reassembly.

5. Loosen "V" clamp (4) and (6).
6. Remove cartridge housing (5) from turbine housing (1).

NOTE

Make sure all oil passages in turbocharger housing are clean and free of dirt and foreign material.

NOTE

Make sure the marks on the housings are in alignment with each other.

NOTE

Put anti-seize compound on threads of "V"-clamp before installation.

7. Install "V"-clamp and tighten to 120 lb-in.
8. Install compressor housing onto the cartridge assembly.
9. Install "V"-clamp and tighten to 120 lb-in.
10. Install gasket (3).
11. Install turbocharger assembly.
12. Install and tighten nuts and washers (2).

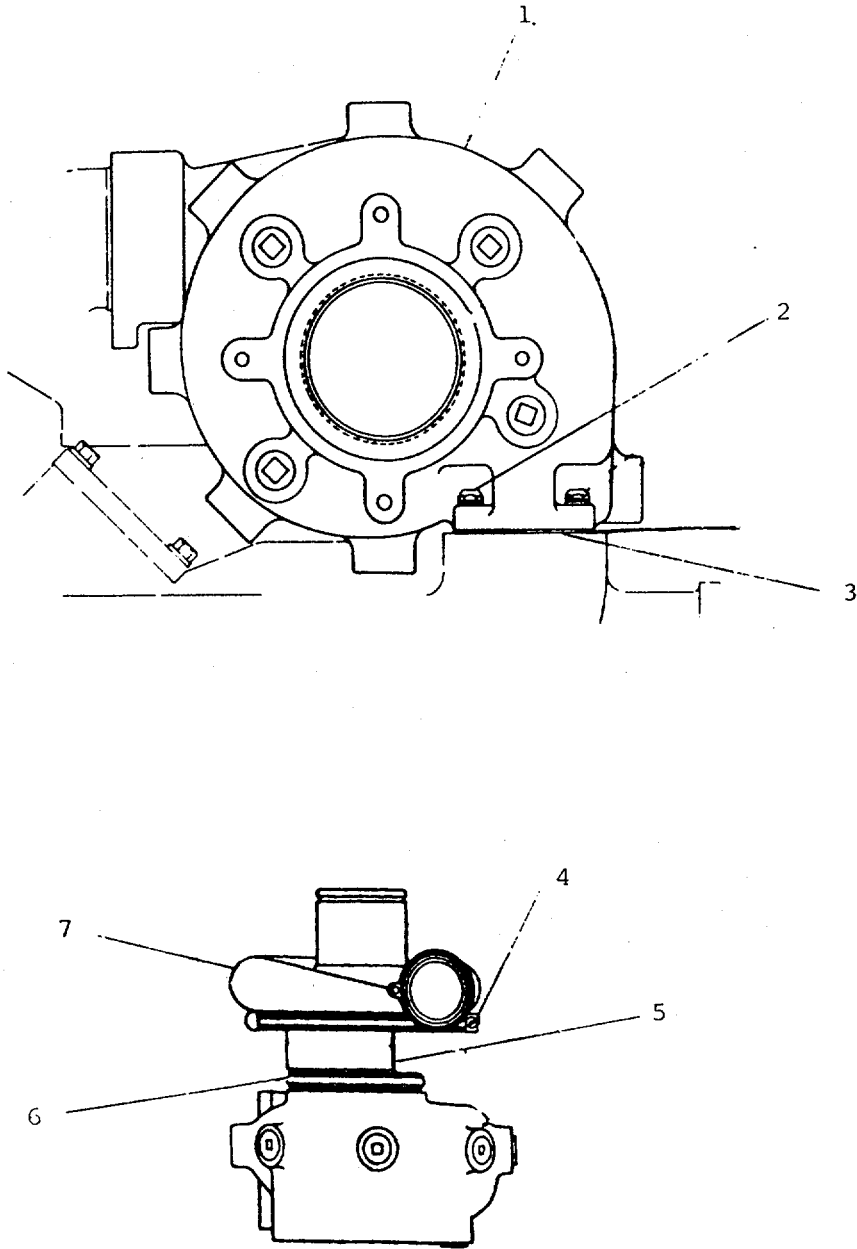

FIGURE 5-6. Turbocharger Assembly

5-10. REPAIR/REPLACE MANIFOLD ASSEMBLY

This Task Covers: a. Repair b. Replacement

INITIAL SETUPTools Required

Tool Kit, General Mechanics
(Appendix B, Item 1)
Tool Kit, Automotive
(Appendix B, Item 3)
Shop Equipment (Appendix B,
Item 2)

Equipment Conditions

Engine Shutdown (para 2-11).
Battery Disconnected (para 4-58).
Air Filter Assembly Removed
(para 4-49).
Turbo Lines Removed (para 4-35).
Air Lines Removed (para 4-31).
Turbocharger Removed (para 5-9).

Materials/Parts Required

Cotton Rags (Appendix E,
Item 3)
Gasket P/N 7W1641
Gasket P/N 7W1642
Gasket P/N 9L8027
Manifold Assembly P/N 2W8470

Personnel Required2 Persons

REPAIR Repair is limited to replacement of defective parts.REPLACEMENT (Figure 5-7)

1. Disconnect hose (1).
2. Remove bolts (2) and bolts (3).
3. Remove elbow (4) and exhaust manifold (10) as a unit.
4. Remove gasket (5).
5. Remove bolts (6).
6. Remove elbow (4).
7. Remove gasket (7).
8. Remove vent line (8).
9. Remove bolts (9).
10. Remove rear manifold assembly (11) and gaskets (12).

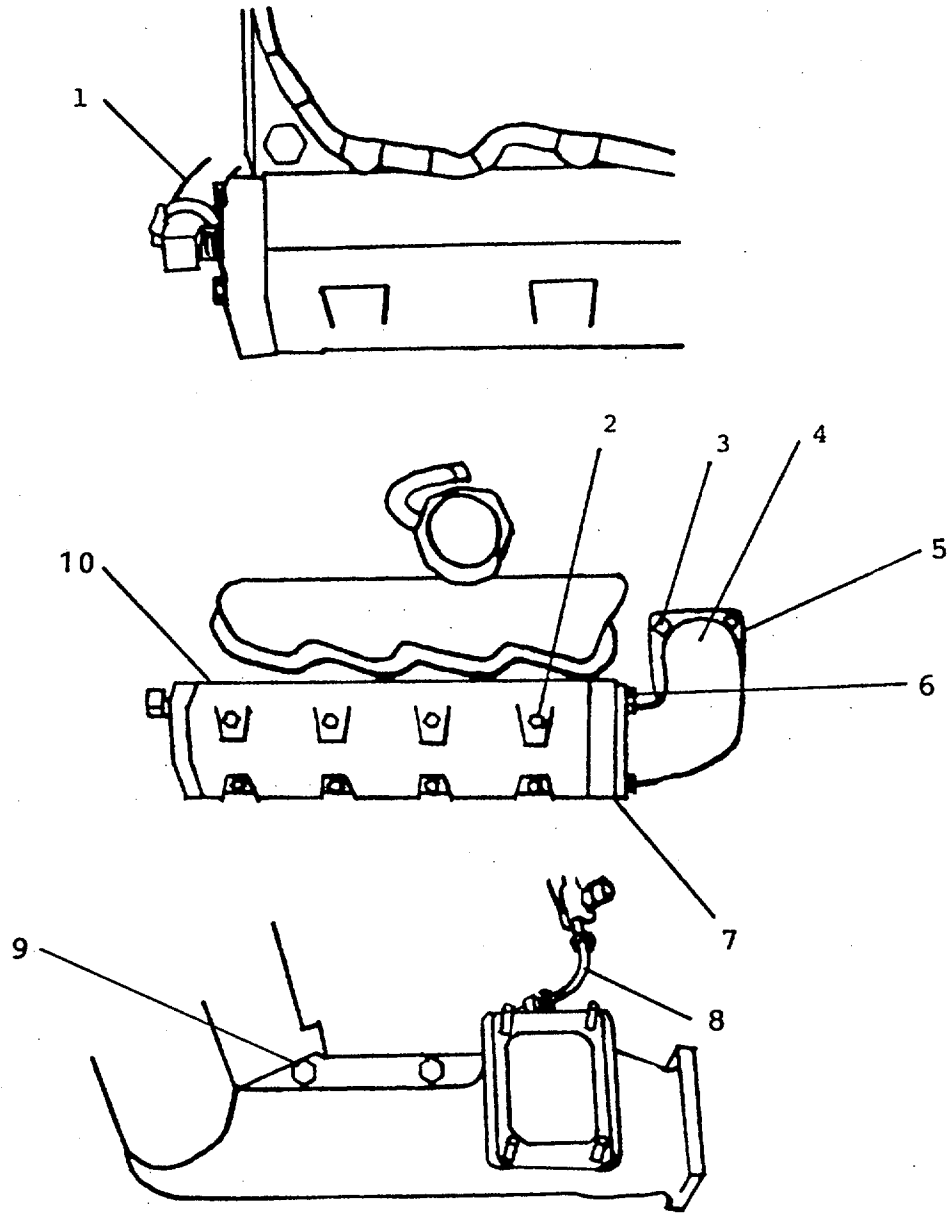

Figure 5-7 (1 of 2) Manifold Assembly

NOTE

Install according to the following steps, but do not tighten bolts until installation is complete.

11. Install rear gaskets (12) and manifold assembly.

NOTE

Tighten the exhaust manifold bolts in letter sequence as follows:
Make sure bolts (A) are tightened to a torque of 32 +/-5 lb.ft.
Tighten bolts (B) through (D) to a torque of 1 lb.ft. finger tight.
Tighten bolts (B) through (D) to a torque of 10 +/-5 lb.ft.
Tighten bolts (B) and (C) to a torque of 32 +/-5 lb.ft.
Tighten bolts (D) to a torque of 75 +/-10 lb.ft.

12. Install bolts (9).
13. Install vent line.
14. Install gasket (7).
15. Install elbow (4).
16. Install bolts (6).
17. Install gasket (5).
18. Install elbow (4) and manifold assembly (5).
19. Install bolts (2) and bolts (3).
20. Connect hose (1).

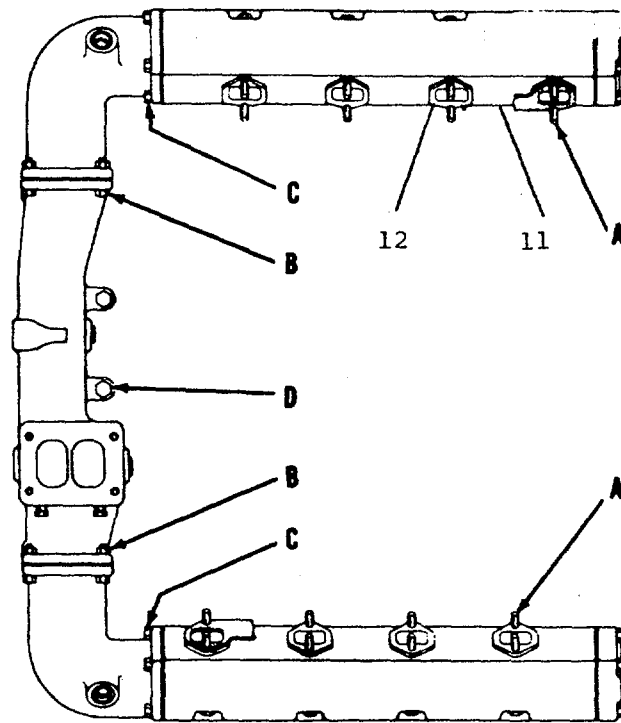

Figure 5-7 (2 of 2). Manifold Assembly

5-11. EXPANSION TANK ASSEMBLY

This Task Covers: a. Test

INITIAL SETUP**Tools Required**

Cooling System Pressurizing
Pump Group (Appendix B,
Item 7)

Equipment Conditions

Engine Shutdown (para 2-11).
Battery Disconnected (para 4-58).

Materials/Parts Required

Cotton Rags (Appendix E,
Item 3)

Personnel Required

1 Person

TEST (Figure 5-8.)**WARNING**

Use caution when removing the expansion tank cap while the engine is still hot.

WARNING

To prevent burns and to prevent damage to the engine, do not add coolant to an overheated engine.
Allow the engine to cool first.

NOTE

If the engine has been operated and the coolant is hot, loosen pressure cap to first stop and let pressure out of system.

1. Remove pressure cap (2) from tank (1).
2. Install pressure cap on pressurizing pump.
3. Increase pump pressure and note pressure that opens cap.

NOTE

The correct operating pressure is stamped on the cap.

4. Compare the pump gauge reading to the cap.
5. Replace cap if it does not open at required pressure.
6. Install pressurizing pump on expansion tank.
7. Pressurize tank to three (3) psi more than pressure stamped on cap.
8. Inspect for leaks on tank and hoses.

NOTE

If pressure drops, inspect for leaks and repair. If pressure does not drop, no leaks are in system.

9. Allow pressure to remain in tank for five (5) minutes.

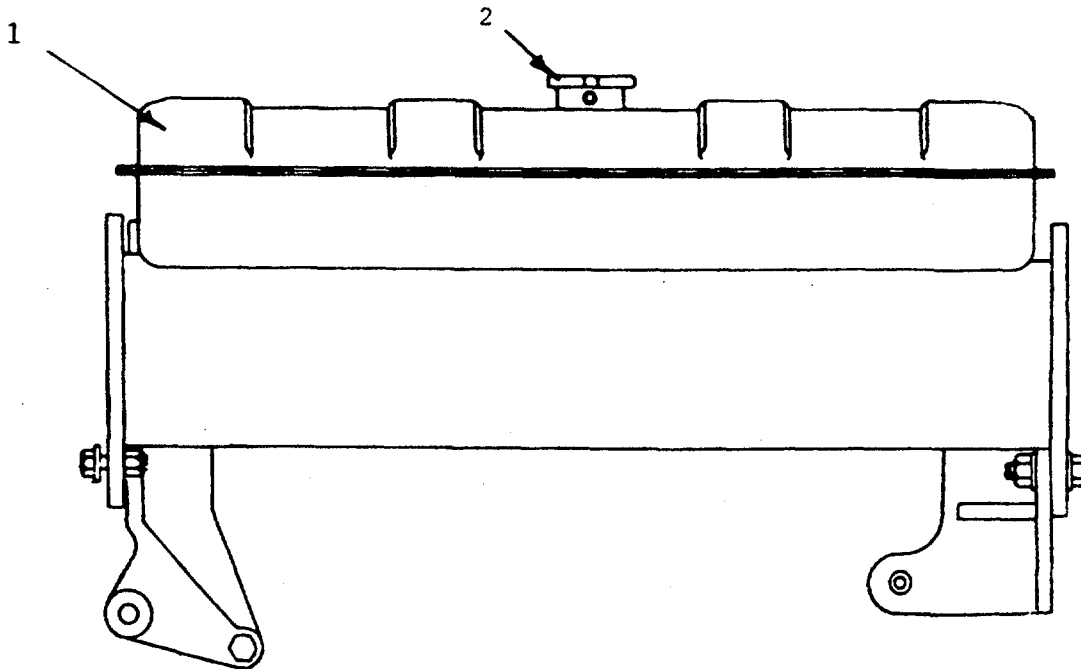

Figure 5-8. Expansion Tank Assembly

5-12. REPAIR/REPLACE OIL PAN ASSEMBLY

This Task Covers: a. Repair b. Replacement

INITIAL SETUP
Tools Required

Tool Kit, General Mechanics
(Appendix B, Item 1)

Equipment Conditions

Engine Shutdown (para 2-11).
Battery Disconnected (para 4-58)
Oil Drained (LO5-2010-205-12).
Oil Level Gauge Removed
(para 4-20).
Engine Raised (para 5-6).

Materials/Parts Required

Cotton Rags (Appendix E,
Item 3)
Pan P/N 4N4475
Packing P/N 3K0360
Plug P/N 9S4185
Gasket P/N 9L8016
Bolt P/N 9L9178
Oil Level Gauge P/N 4N4542

Personnel Required

2 Persons

REPAIR Repair is limited to the replacement of defective parts.

REPLACEMENT (Figure 5-9.)

1. Disconnect turbocharger from oil drain line (1).
2. Remove bolts (2).
3. Remove pan (3).
4. Remove gasket (4).
5. Install new gasket (4).
6. Install pan (3).
7. Install and tighten bolts (2) to 17 lb.-ft.
8. Connect oil line (1).

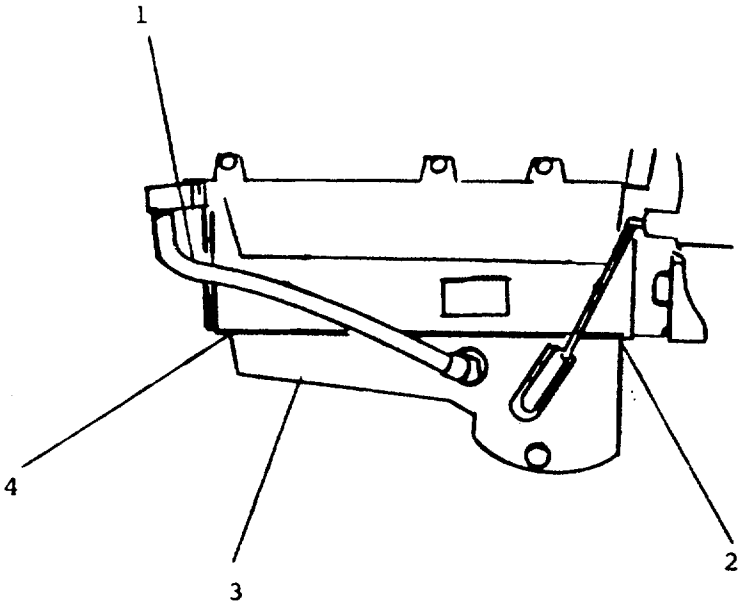

Figure 5-9. Oil Pan Assembly

5-13. REPLACE GOVERNOR CONTROL ASSEMBLY

This Task Covers: a. Replacement

INITIAL SETUP**Tools Required**

Tool Kit, General Mechanics
(Appendix B, Item 1)

Materials/Parts Required

Cotton Rags (Appendix E,
Item 3)
Lever P/N 6N3646

Equipment Conditions

Engine Shutdown (para 2-11).
Battery Disconnected (para 4-58).

Personnel Required

1 Person

REPLACEMENT (Figure 5-10.)

1. Loosen and remove bolt (4) and washer (3).
2. Remove lever (1).
3. Install lever (1) over shaft (2).
4. Install and tighten bolt (4) and washer (3).

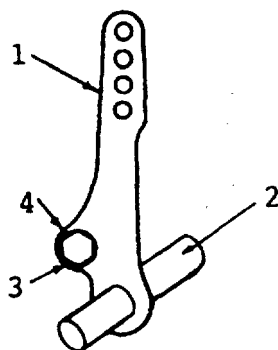

Figure 5-10. Governor Control Assembly

5-14. REPLACE FLYWHEEL HOUSING ASSEMBLY

This Task Covers: a. Replacement

INITIAL SETUPTools Required

Tool Kit, General Mechanics
(Appendix B, Item 1)
Hoist (Appendix B, Item 4)

Equipment Conditions

Engine Shutdown (para 2-11).
Battery Disconnected (para 4-58).
Starter Removed (para 4-44).
Hydraulic Pump Removed
(para 5-25).
Flywheel Removed (para 5-17).

Materials/Parts Required

Cotton Rags (Appendix E,
Item 3)
Gasket P/N 9N6316

Personnel Required

2 Persons

REPLACEMENT (Figure 5-11.)

1. Remove bolt (3).
2. Remove grounding cable (4).
3. Remove bolts (5).
4. Remove bracket (6).
5. Remove bolts (7).
6. Loosen front engine mounting bolts.
7. Raise engine with hoist slightly and block underneath.
8. Remove bolts (8).
9. Remove housing (1).
10. Remove gasket (2).

NOTE

Before reassembly, clean all surfaces thoroughly.

NOTE

Before reassembly, put clean oil on lip of rear seal.

11. Install new gasket (2).
12. Install housing (1).
13. Install and tighten bolts (8).

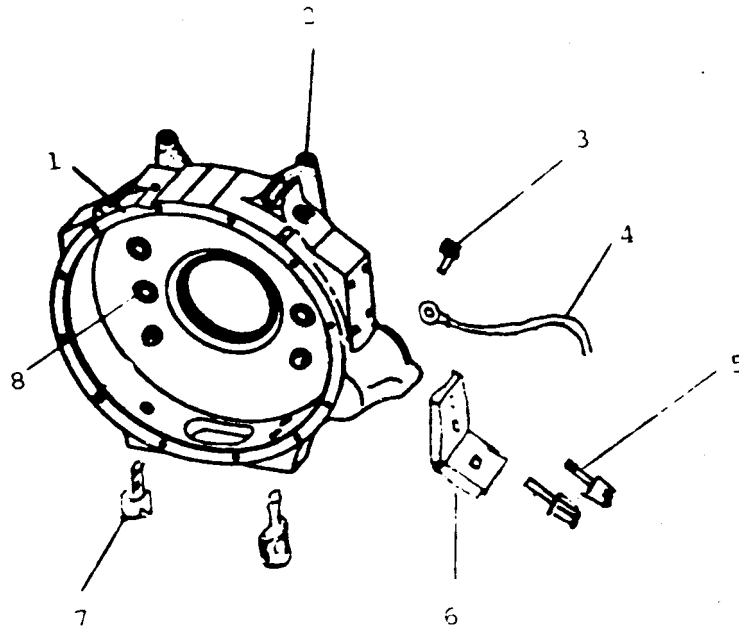

Figure 5-11. Flywheel Housing Assembly

14. Raise engine enough to remove blocking.
15. Lower engine.
16. Install and tighten bolts (7).
17. Install bracket (6).
18. Install and tighten bolts (5).
19. Install cable (4).
20. Install and tighten bolt (3).

5-15. REPAIR SEAWATER EXCHANGER ASSEMBLY

This Task Covers: a. Test b. Repair

INITIAL SETUP
Tools Required

Tool Kit, General Mechanics
 (Appendix B, Item 1)
 Pump Group (Appendix B,
 Item 7)

Materials/Parts Required

Cotton Rags (App. E,
 Item 3)
 Permanent Antifreeze
 (Appendix E, Item 4)
 Bolt P/N 0S1588
 Packing P/N 1S1225
 Core Assembly P/N 1W3421
 Gasket P/N 4W6949
 Gasket P/N 4W6950
 Washer P/N 5P1075
 Anode P/N 6L2283
 Anode P/N 6L2289

Equipment Conditions

Engine Shutdown (para 2-11).
 Battery Disconnected (para 4-58).
 Tank and Exchanger Removed
 (para 4-24).

Personnel Required

2 Persons

TEST Refer to para 5-11.

REPAIR Repair is limited to replacement of defective parts. (Refer to para 4-17.)

5-16. REPLACE GOVERNOR PUMP ASSEMBLY

This Task Covers: a. Replacement

INITIAL SETUP
Tools Required

Tool Kit, General Mechanics
(Appendix B, Item 1)
Timing Pin (appendix B, Item 6)
Plate (Appendix B, Item 5)
Bolts (Appendix B, Item 22)
Bolt, 5/16-18 NC by 2-1/2" long

Equipment Conditions

Engine Shutdown (para 2-11).
Battery Disconnected (para 4-58).
Air Filter Removed (para 4-49).
Fuel Injection Lines Removed
(para 4-29).
Manifold Assembly Removed
(para 5-10).
Expansion Tank Removed
(para 4-17).
Guard Removed (para 4-48).

Materials/Parts Required

Cotton Rags (Appendix E,
Item 3)
Governor Pump Assembly
P/N 7C9496

Personnel Required

2 Persons

REPLACEMENT (Figure 5-12.)

1. Remove plug (1) from cover (9).
2. Install timing pin (3).
3. Rotate engine crankshaft (11) clockwise until timing pin (3) drops into slot in fuel injection pump camshaft (10).
4. Remove nuts (2).
5. Remove tachometer drive cover (4).
6. Remove tachometer drive shaft (5).
7. Install plate with bolts into camshaft drive gear (12).
8. Turn bolts evenly until drivegear is free.
9. Remove tooling.
10. Remove plug (6) from timing hole in front cover.

11. Install 5/16 by 2 1/2 inch bolt in timing hole.

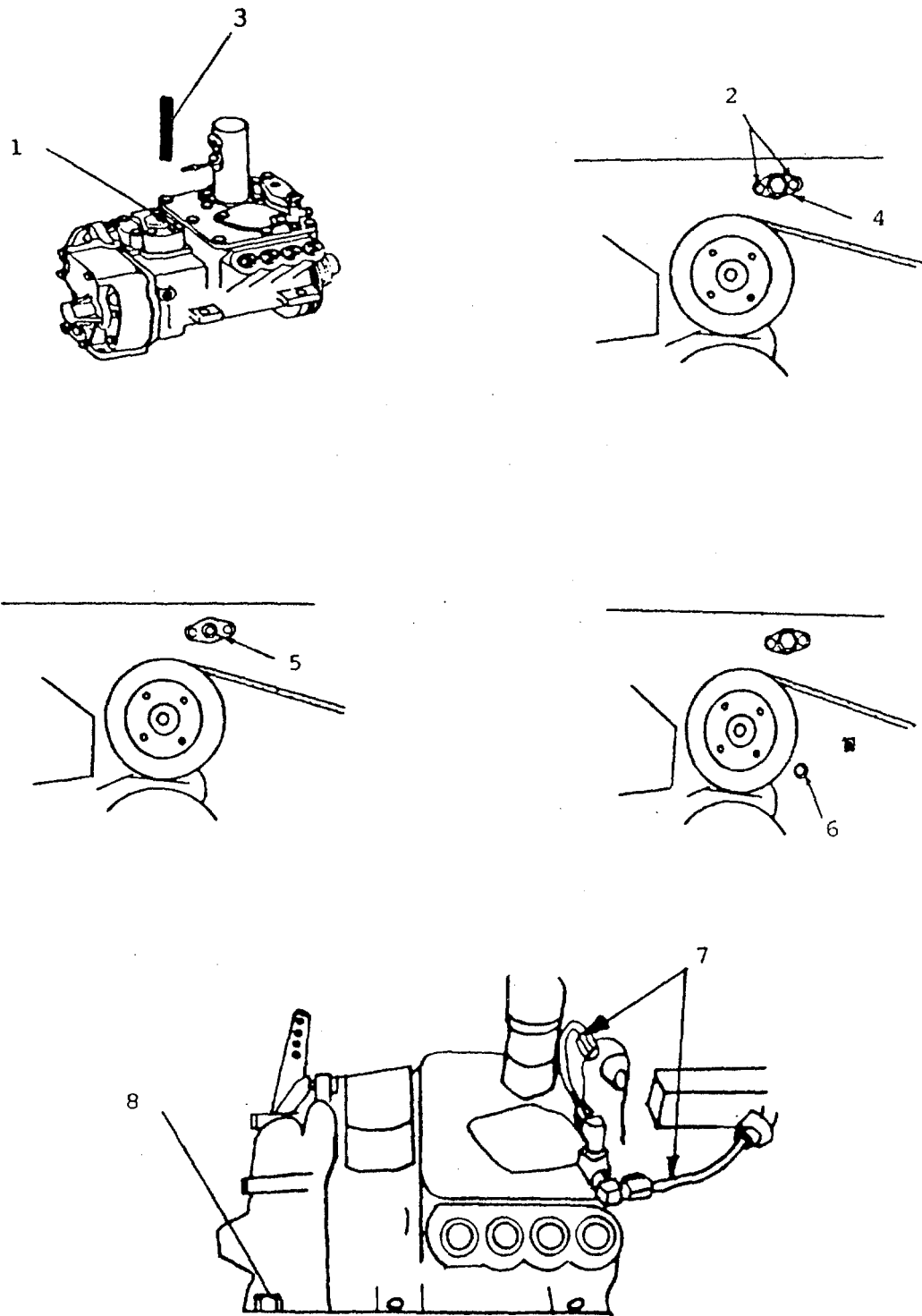

Figure 5-12. Governor Pump Assembly

12. Turn crankshaft clockwise until bolt can be installed in timing gear and is in the center of timing hole.
13. Remove lines (11).
14. Remove bolts (12).

NOTE

Governor and fuel injection pump will be removed as an assembly.

15. Remove governor.
16. Install fuel injection pump housing and governor as a unit onto the engine.
17. Install bolts (12).
18. Install tachometer drive shaft (9).
19. Tighten drive shaft to 110 lb-ft.
20. Remove 5/16 x 2 1/2 inch bolt from timing hole.
21. Install plug (10).
22. Remove timing pin.
23. Install plug (1).
24. Install lines (11).
25. Install tachometer cover (6).
26. Install cover nuts (5).

5-17. REPLACE FLYWHEEL ASSEMBLY

This Task Covers: a. Inspect b. Replacement

INITIAL SETUP**Tools Required**

Tool Kit, General Mechanics
(Appendix B, Item 1)

Equipment Conditions

Engine Shutdown (para 2-11).
Battery Disconnected (para 4-58).
Hydraulic Pump Removed
(para 4-51).
Starter Removed (para 4-44).

Materials/Parts Required

Cotton Rags (Appendix E,
Item 3)
Gasket Sealant (Appendix E,
Item 9)
Flywheel Assembly P/N 7W1534

Personnel Required

2 Persons

INSPECT (Figure 5-13.)

1. Inspect for loose bolts (2).
2. Inspect for damage.

REPLACEMENT

1. Remove bolts (2).
2. Remove flywheel (1).

NOTE

Make sure gasket sealant is put on bolt threads before reinstalling.
Oil leaks can result if sealant is not used.

CAUTION

Before installing new flywheel, check the thickness at the bolt holes. This thickness must be the same as the old flywheel.

3. Install flywheel (1) on crankshaft (3).
4. Install and tighten bolts (2).

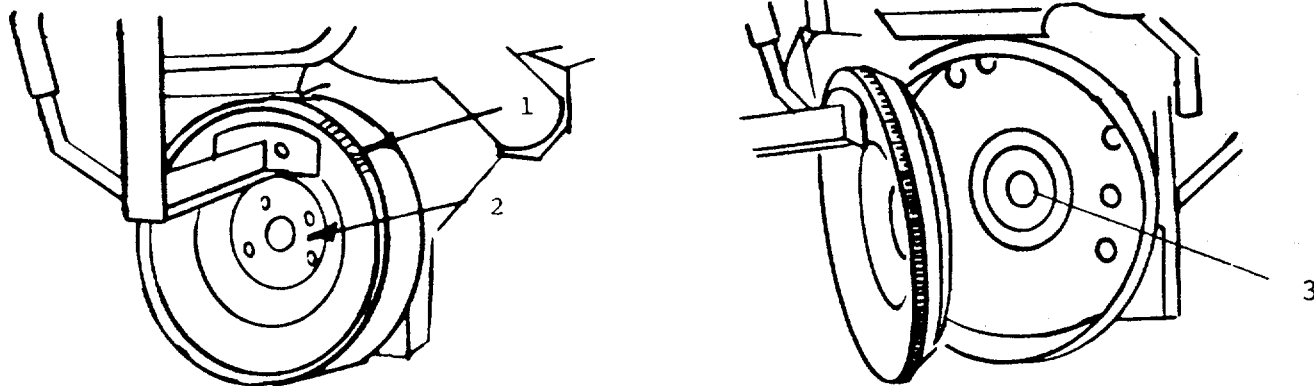

Figure 5-13. Flywheel Assembly

5-18. FRONT HOUSING ASSEMBLY

This Task Covers: a. Inspect

INITIAL SETUP**Tools Required**

Tool Kit, General Mechanics
(Appendix B, Item 1)

Materials/Parts Required

Cotton Rags (Appendix E, Item 3)

Equipment Conditions

Engine Shutdown (para 2-11).
Battery Disconnected (para 458).
Squirrel Cage Fan Removed
(para 4-59).
Guard Assembly Removed
(para 4-48).

Personnel Required

1 Person

INSPECT (Figure 5-14).

1. Inspect for leaks at gasket (2).
2. Inspect for loose plugs (1).

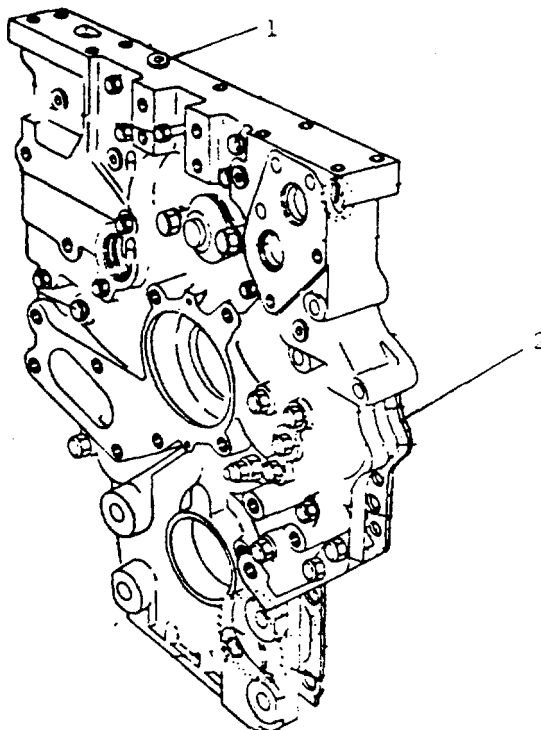

Figure 5-14. Front Housing Assembly

5-19. REPLACE FASTENER ASSEMBLY

This Task Covers: a. Replacement

INITIAL SETUPTools Required

Tool Kit, General Mechanics
(Appendix B, Item 1)

Equipment Conditions

Engine Shutdown (para 2-11).
Battery Disconnected (para 4-58).
Air Filter Removed (para 4-49).
Fuel Injection Lines Removed
(para 4-29).
Manifold Assembly Removed
(para 5-10).
Expansion Tank Removed
(para 4-17).
Guard Removed (para 4-48).
Governor Removed (para 5-16).

Materials/Parts Required

Cotton Rags (Appendix E,
Item 3)
Seal P/N 8M8157
Seal P/N 9M9729
Fastener Assembly P/N 9L6925

Personnel Required

2 Persons

REPLACEMENT (Figure 5-15.)

1. Remove seal (1).
2. Remove bolt and washer (2).
3. Remove seal (3).
4. Install new seal (3).
5. Install bolt and washer (2)
6. Install new seal (1).

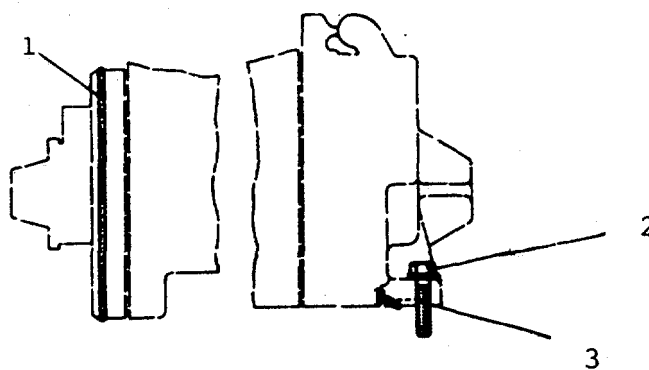

Figure 5-15. Fastener Assembly
5-36

5-20. REPAIR/REPLACE CYLINDER HEAD ASSEMBLY

This Task Covers: a. Repair b. Replacement

INITIAL SETUPTools Required

Tool Kit, General Mechanics
(Appendix B, Item 1)
Shop Equipment (Appendix B,
Item 2)
Shop Equipment (Appendix B,
Item 4)
Dial Indicator (Appendix B,
Item 10)
Valve Seat Insert Puller
(Appendix B, Item 17)
Valve Spring Compressor
(Appendix B, Item 16)

Materials/Parts Required

Masking Tape (Appendix E,
Item 7)
Cotton Rags (Appendix E,
Item 3)
Lubricating Oil (Appendix E,
Item 2)
Screw P/N OS1571
Washer P/N 1W9897
Lock P/N 2A4429
Seat P/N 2N8943
Plug P/N 8M5860
Seat P/N 9N2837
Valve P/N 9L7682
Valve P/N 9N5125
Spring P/N 9N5495
Spring P/N 9N5496
Seat P/N 9N5497
Bolt P/N FFB575
Screw P/N 2B0947
Bolt P/N 2B2006
Washer P/N 6299613
Bolt P/N MIL-3-1222
Screw P/N M590728-78
Gasket P/N 7C1599
Plug P/N 9L7657
Bolt P/N 9L9165

Equipment Conditions

Engine Shutdown (para 2-11).
Battery Disconnected (para 4-58).
Exhaust Manifold Removed
(para 4-40).
Air Inlet Manifold Removed
(para 4-16).
Air Intake Filter Removed
(para 4-49).
PCV Lines Removed
(para 4-33.)
Valve Cover Removed (para 4-30).
Valve Mechanism Removed
(para 5-21).
Fuel Injection Lines Removed
(para 4-29).

Personnel Required

2 Persons

Gasket P/N 7C0939
 Manifold P/N 8N1298
 Gasket P/N 9L8786
 Gasket P/N 9L8837
 Filter Element P/N 7W5040
 Gasket P/N 9L8020
 Bolt P/N MS90728-43
 Tappet P/N 9L6931
 Bolt P/N MS90728-40
 Rocker Arm P/N 2W8271
 Washer P/N 2W6047
 Screw P/N 5S5917
 Nut P/N 9L7712
 Washer P/N 9L8076
 Shaft P/N 9L9315
 Washer P/N 9M1974
 Holder P/N 9N0141
 Push Rod P/N 9N6500
 Gasket P/N 9N5497
 Gasket P/N 7C1599
 Cylinder Head Assembly P/N 9N3600

REPAIR Repair is limited to the replacement of defective parts.

REPLACEMENT (Figure 5-16, 5-17)

CAUTION

Make sure fuel injection nozzles are removed before cylinder heads are removed.

1. Remove clamp (2) from water sleeves (1).
2. Push water sleeves into timing gear cover (3).
3. Remove bolts (4) and (5).
4. Remove cylinder head (6).
5. Compress valve springs (7).
6. Remove locks (8).
7. Remove retainer (9), spring (10), washer (11), and valve (12).

NOTE

Tag each valve to show which cylinder to reinstall into.

8. Complete steps 5 through 7 for each cylinder.

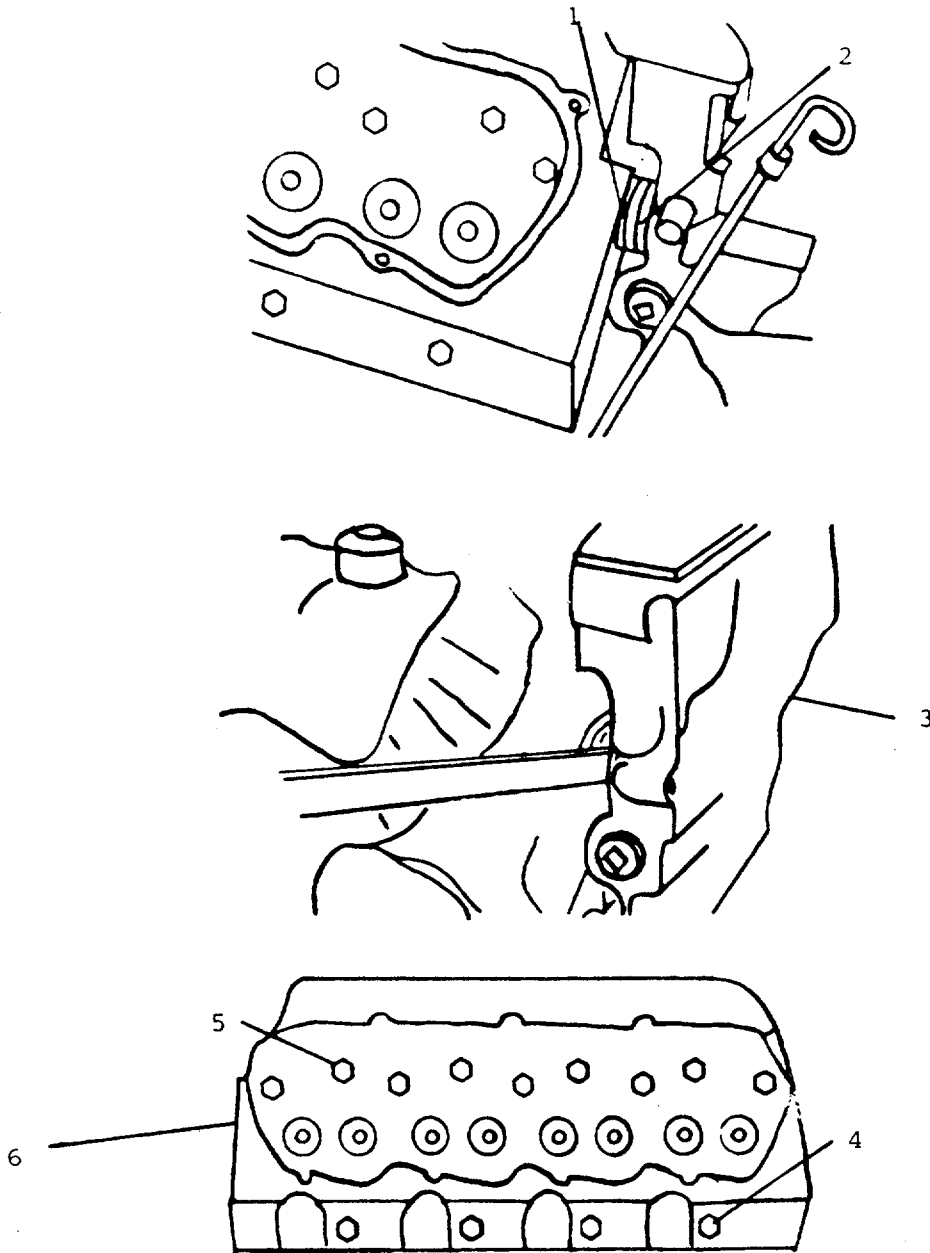

Figure 5-16 (1 of 2). Cylinder Head Assembly

9. Remove valve seat inserts (13).
10. Lower temperature of valve seats and install.

NOTE

Use clean lubricating oil on parts when reinstalling.

11. Install valve (12), washer (11), spring (10), and retainer (9).
12. Compress valve spring.
13. Install lock (8).
14. Hit valve with rubber hammer to be sure locks are positioned correctly.
15. Repeat steps 11 through 14 for each cylinder.
16. Install cylinder head gasket.

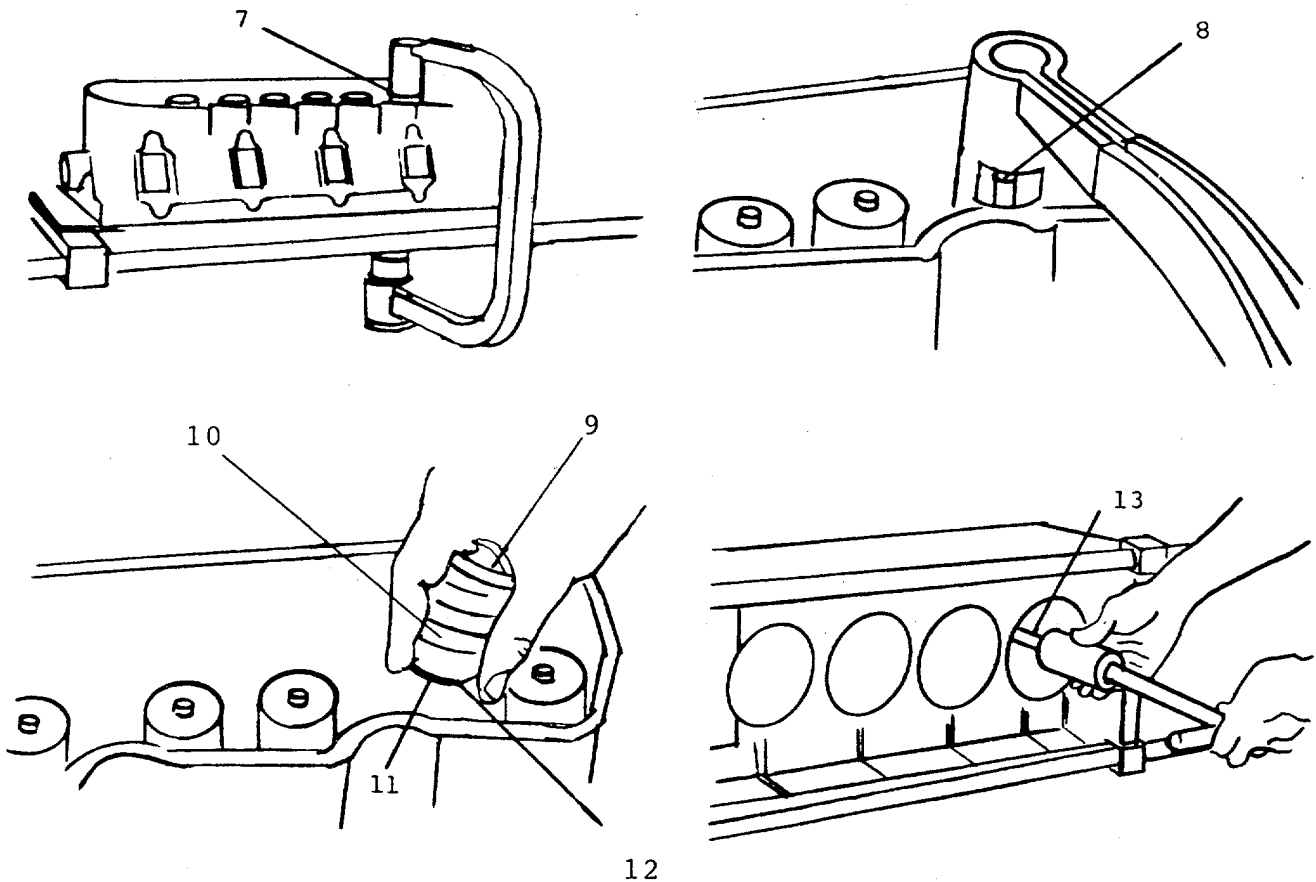

Figure 5-16 (2 of 2). Cylinder Head Assembly

NOTE

Insure all surfaces are clean before reinstalling.

NOTE

Clean bore in cylinder head for the water sleeves.

NOTE

Put lubricating oil on the water seals.

17. Install cylinder head on cylinder block.

18. Put lubricating oil on bolt threads.

CAUTION

Refer to chart and see Figure 5-17. before installing head bolts.

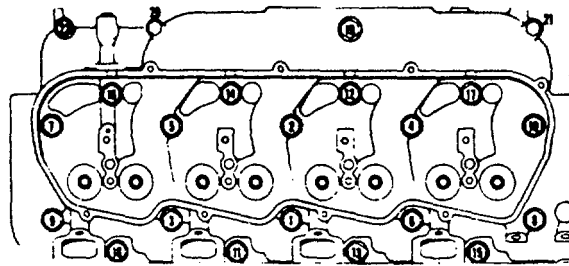

Figure 5-17. Head Bolt Locations

<u>Location</u>	<u>Length</u>
5, 2, 4, 10	5.25 in.
19, 20, 21	5.0 in.
16, 14, 12, 17	3.0 in.
7, 9, 3.1, 6, 8	4.75 in.
18, 11, 13, 15	2.25 in.
22	Stud

19. Install bolts and tighten accordingly:
- Tighten bolts 1-18 in sequence to 60 lb.-ft.
 - Tighten bolts 1-18 in sequence to 110 lb.-ft.
 - Again, tighten bolts 1-18 in sequence to 110 lb.-ft.
 - Tighten bolts 19-22 in sequence to 32 lb.-ft.

20. Install water sleeve into cylinder head.

21. Install clamp (2) onto water sleeves.

 5-21. REPAIR/REPLACE VALVE MECHANISM ASSEMBLY

 This Task Covers: a. Repair b. Replacement c. Adjust

INITIAL SETUPTools Required

Tool Kit, General Mechanics
 (Appendix B, Item 1)
 Shop Equipment (Appendix B,
 Item 4)

Equipment Conditions

Engine Shutdown (para 2-11).
 Battery Disconnected (para 4-58).
 Air Intake Filter Removed
 (para 4-49).
 PCV Lines Removed (para 4-33).
 Valve Covers Removed (para 4-30).

Materials/Parts Required

Cotton Rags (Appendix E,
 Item 3)
 Cleaning Solution (Appendix E,
 Item 1)
 Gasket Sealing Compound
 (Appendix E, Item 6)
 Valve Mechanism Assembly
 P/N 9N3603
 Bolt P/N MS90728-43
 Tappet P/N 9L6931
 Bolt P/N MS90728-40
 Rocker Arm P/N 2W8271
 Washer P/N 2W6047
 Screw P/N 5S5917
 Nut P/N 9L7712
 Washer P/N 9L8076
 Shaft P/N 9L9315
 Washer P/N 9M1974
 Holder P/N 9N0141
 Push Rod P/N 9N6500
 Gasket P/N 9L8020
 Gasket P/N 9L8786
 Gasket P/N 9L8837
 Filter Element P/N 7W5040

Personnel Required

1 Person

REPAIR Repair is limited to the replacement of defective parts (Figure 5-18).

REPLACEMENT

1. Remove bolts (3).
2. Remove rocker shaft (4).
3. Loosen nut (1) and screws (2).

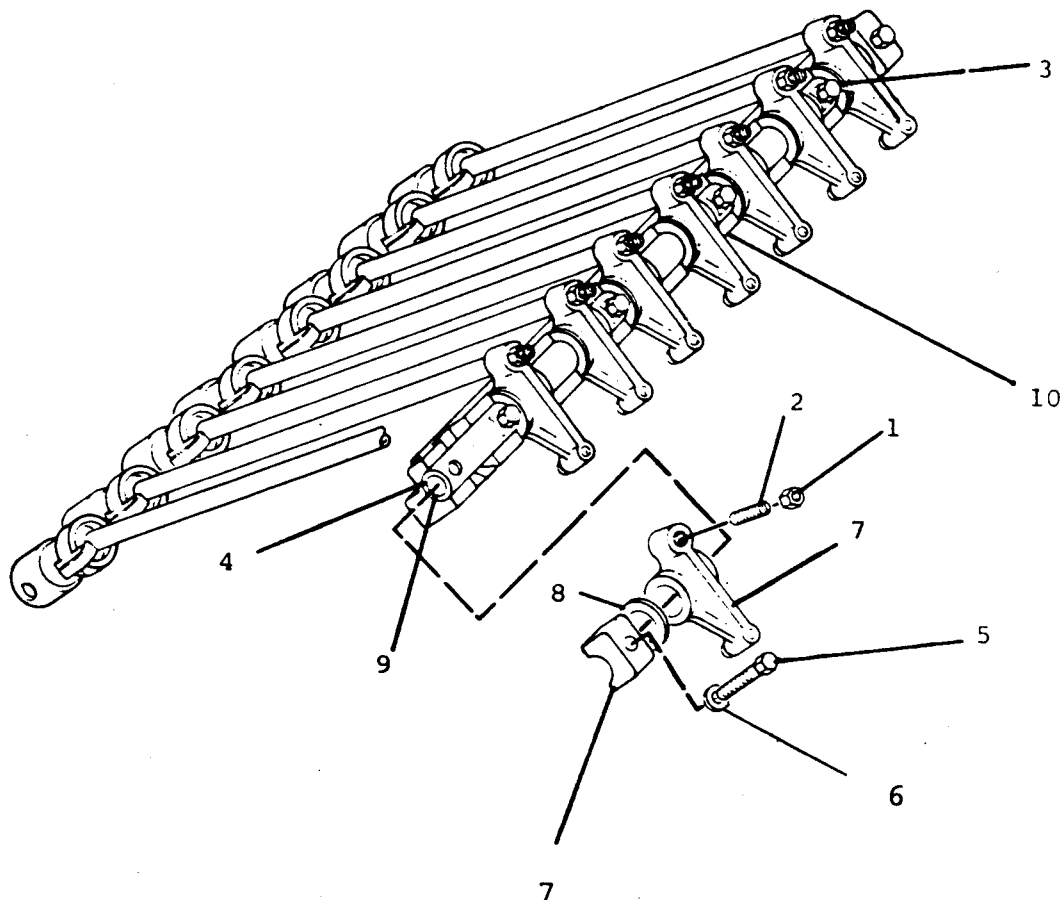

Figure 5-18. Valve Mechanism Assembly.

4. Remove bolts (5) and washers (6).
5. Remove locks (7).
6. Remove shaft (4) from bracket (10).
7. Remove rocker arm assemblies (7) and washers (8) from shaft (9).
8. Remove screw (2) and nut (1) from assembly (7).

NOTE

Make sure oil holes in rocker arm, rocker shaft, and bracket are clean before reinstallation.

9. Measure diameter of bore of bushing in rocker arm.

NOTE

The bore diameter must be between .8595 and .8611 inch. Replace arm and bushing as a unit if bore is incorrect.

10. Measure diameter of shaft at each rocker arm location.

NOTE

Shaft diameter must be .8580 to .8588 inch or will be replaced.

11. Install screws (2) and nuts (1) onto rocker arm (7).

NOTE

Turn screws (2) until they are .44 inch below bottom of rocker arm assembly.

12. Install rocker arm assemblies (7) and washers (8) onto shaft (4).
13. Install shaft assembly onto bracket (10).

NOTE

Adjustment screws must be on same side as oil hole on bottom of bracket.

NOTE

Make sure that flat surfaces on shaft (4) are turned up.

14. Install locks (6), bolts (5) and washers.
15. Position rocker arm assembly on engine.
16. Adjust rocker arms and valves (steps 1 through 5).
17. Tighten bolts (3).

ADJUST

1. Loosen nut (1) and screws (2).
2. Adjust intake valve clearance to .015 inch.
3. Tighten screws (2) and nut (1).
4. Adjust exhaust valve clearance to .025 inch.

NOTE

Tighten nuts (1) to a torque of 24 lb.-ft.

5. Tighten screw (2) and nut (1).

5-22. REPLACE ENGINE SUPPORT ASSEMBLY

This Task Covers: a. Replacement

INITIAL SETUPTools Required

Tool Kit, General Mechanics
(Appendix B, Item 1)
Hoist (Appendix B, Item 4)

Equipment Conditions

Engine Shutdown (para 2-11).
Battery Disconnected (para 4-58)
Hand Pump Removed (para 4-60).

Materials/Parts Required

Cotton Rags (Appendix E,
Item 3)
Engine Support Bracket
P/N 9N5799

Personnel Required

2 Persons

REPLACEMENT (Figure 5-19.)

1. Loosen front engine support bolts (2).
2. Remove engine mount bolts (6), and washers (5).
3. Remove bracket bolts (4) and washers.
4. Raise engine with hoist approximately 1/8 inch.
5. Remove engine support bracket (1).
6. Install new engine support bracket (1).
7. Install engine mount, washers (3), and bolts (4).
8. Lower engine.
9. Install and tighten washers (5) and bolts (6).
10. Tighten bolts (2).

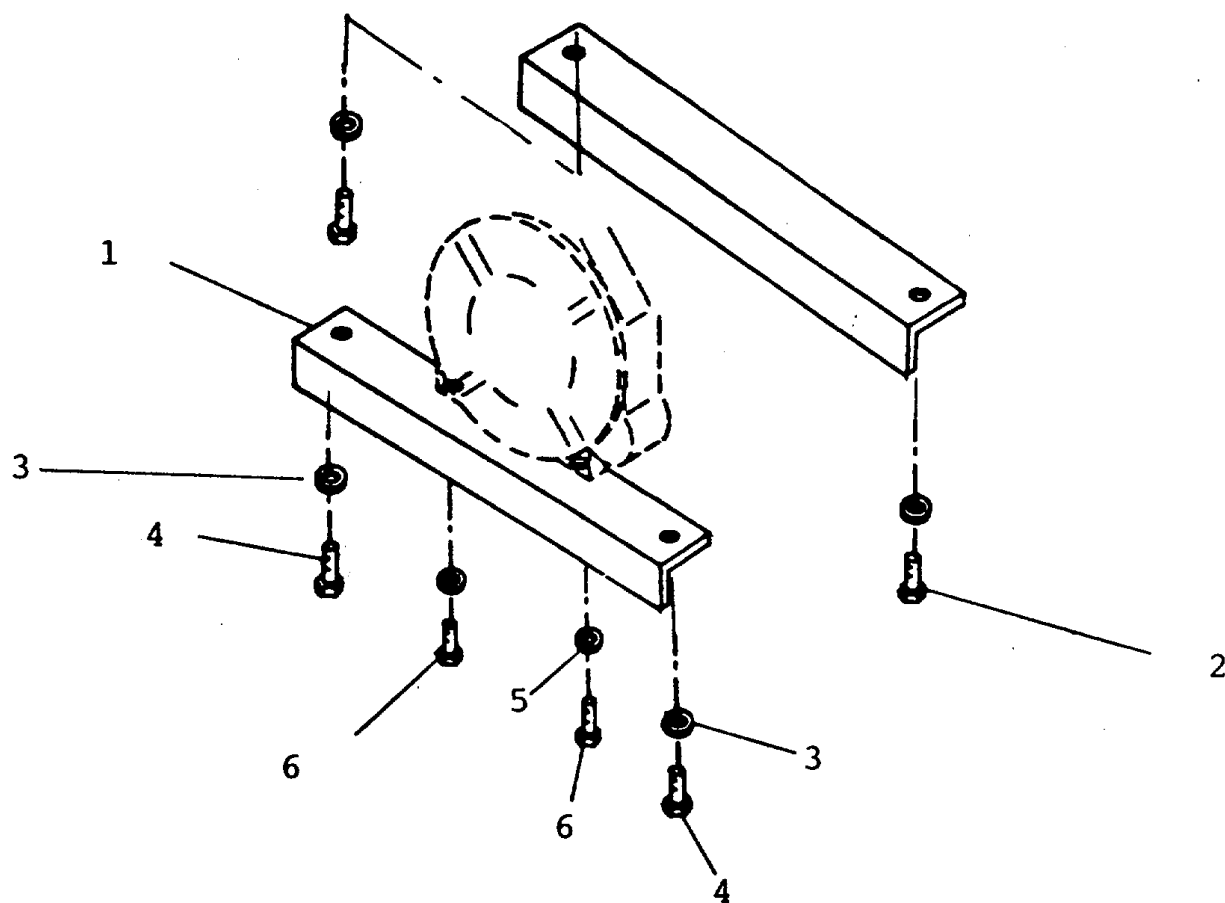

Figure 5-19. Engine Support Assembly.

5-23. CYLINDER BLOCK ASSEMBLY

This Task Covers: a. Inspect

INITIAL SETUPTools Required

Tool Kit, General Mechanics
(Appendix B, Item 1)

Materials/Parts Required

Cotton Rags (Appendix E,
Item 3)

Equipment Conditions

Engine Shutdown (para 2-11).
Battery Disconnected (para 4-58).
Air Intake Filter Removed
(para 4-49).
PCV Lines Removed
(para 4-33).
Fuel Injection Lines Removed
(para 4-29).
Air Inlet Manifold Removed
(para 4-10).
Valve Cover Removed
(para 4-30).
Valve Mechanism Removed
(para 5-21).
Exhaust Manifold Removed
(para 4-40).
Cylinder Head Removed
(para 5-20).

Personnel Required

2 Persons

INSPECT (Figure 5-20.)

1. Inspect for damage.
2. Inspect top for flatness.

NOTE

Top must not vary more than .003 inch from "A" to "C".
Top must not vary more than .009 inch from "B" to "D".

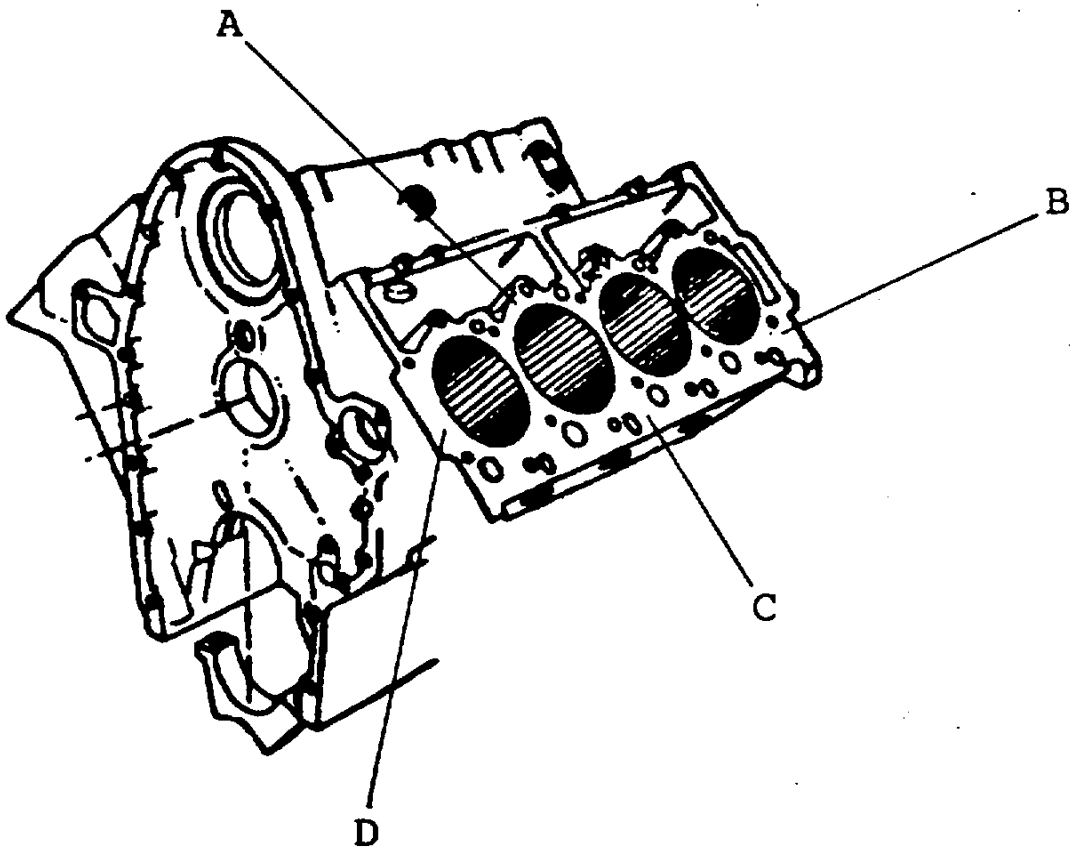

Figure 5-20. Cylinder Block Assembly.

5-24. REPAIR STARTER MOTOR ASSEMBLY

This Task Covers: a. Repair

INITIAL SETUP

Tools Required

Tool Kit, General Mechanics
(Appendix B, Item 1)

Equipment Conditions

Engine Shutdown (para 2-11).
Battery Disconnected (para 4-58).
Starter Removed (para 4-44).

Materials/Parts Required

Cotton Rags (Appendix E,
Item 3)
Cleaning Solvent (Appendix E,
Item 1)
Brush, Wire Scratch (Appendix D)
Parts Kit, Electric P/N 8T9885
Parts Kit, Electric P/N 7T3267
Parts Kit, Electric P/N 8T9884
Parts Kit, Electric P/N 7T3268

Personnel Required

1 Person

REPAIR (Figure 5-21.)

1. Repair is limited to the replacement of defective parts.
2. Remove nuts (16), washers (17), and washers (15).
3. Remove insulation, bushing, and spacer (18).
4. Remove screws (14).
5. Remove housing cap (13).
6. Remove terminal (12), O-ring (11), and holder (8) from cap (13).
7. Remove screw (10) from brush (9).
8. Remove spring (19).
9. Pull housing (7) from armature assembly (20).
10. Remove bushing (20), washer (21), and screws (3).
11. Remove shoe (4), insulator (2), and spacer (6).
12. Separate armature (1) from coil (5).

19. Install screw (10) into brush (9).
20. Install terminal (12), O-ring (11), and holder (8) into cap (13).
21. Install housing cap (13).
22. Install screws (14).
23. Install insulation, bushing, and spacer (18).
24. Install nuts (16), washers (17), and washers (15).

5-25. REPAIR/REPLACE HYDRAULIC PUMP ASSEMBLY

This Task Covers: a. Repair b. Replacement

INITIAL SETUP
Tools Required

Tool Kit, General Mechanics
 (Appendix B, Item 1)
 Bar (Appendix B, Item 2)
 Nylon Strap

Equipment Conditions

Engine Shutdown (para 2-11).
 Battery Disconnected (para 4-58).
 Hydraulic Reservoir Valve Closed
 (LO5-2010-205-12)
 Covers Removed (para 5-5).
 Exhaust System Removed
 (para 4-50).

Materials/Parts Required

Cotton Rags (App. E, Item 3)
 O-ring P/N 631-45007
 O-ring P/N 033-53575-C
 O-ring P/N 691-00916
 Hydraulic Pump
 P/N P11 P-R1 4-4A2-A-MJ2-04280
 Screw P/N P07154
 Screw P/N M590728-62
 Plug P/N P10137
 Screw P/N MS90728-111
 Washer P/N MS51412-10
 Nut P/N MS25082-19
 Bolt P/N MS90728-32
 Washer P/N MS51412-5
 Bumper Strip P/N 3MD-1
 Tube P/N B100386
 Valve P/N P16008
 Hose P/N E7HU0608MB06NJ-40
 Elbow P/N 849-PS-06X04
 Hose P/N E7HU0606MB06NJ-45
 Screw P/N MJ90728-189
 Washer P/N P07013
 Screw P/N MS990728-170
 Nut P/N MS25082-10
 Washer P/N P07020
 Mount P/N CBA24-650
 Gasket P/N P05032
 Cap P/N UC-PAB-1730-440-5
 Gauge P/N P17000
 Bolt P/N P07155
 Washer P/N MS51416-2
 Screw P/N MS90728-58
 Washer P/N MS35338-46
 Screw P/N MS90728-60
 Pump Drive P/N DP01-2-11-E4

Personnel Required

2 Persons

Screw P/N MS90728-189
Washer P/N P07013
Pumping Unit
 P/N P11P-1R1 4-4A2-A-M2-04280
Valve P/N S23-11425-ND
Screw P/N 306-40189
Cover P/N S13-42064-C
Valve P/N S23-11513-C
Screw P/N 359-15220
Packing P/N 691-00916
Pump P/N TKP4-26-14.3DSC06
Gasket P/N P050001
Gasket P/N 48-40
Muffler P/N DCU-04-0410
Adapter P/N 64-40
Adapter P/N C100454
Elbow P/N C100453
Elbow P/N 56-40

REPAIR Repair is limited to the replacement of defective parts.

REPLACEMENT (Figure 5-22.)

1. Disconnect all hydraulic hoses.
2. Disconnect cable from lever (9).
3. Use bar and fasten nylon strap around pump.
4. Loosen and remove bolts (6) and washers (7).
5. Remove assembly from engine.
6. Remove bolts (3) and washers (4).
7. Remove pump (5) from adapter (8).
8. Loosen connections and remove tubing assembly (10).
9. Remove screws (2).
10. Remove valve block assembly (1) and O-rings (14) and (15).
11. Remove screws (11).
12. Remove auxiliary pump (12) and O-ring (13).
13. Install auxiliary pump (12) and new O-ring (13).

14. Install and tighten screws (11).
15. Install valve block assembly (1) and new O-rings (14) and (15).
16. Install and tighten screws (2).
17. Install tubing assembly (10) and tighten connections.
18. Install adapter (8) onto pump (5).
19. Install and tighten washers (4) and bolts (3).
20. Install assembly onto engine.
21. Install and tighten washers (7) and bolts (6).
22. Connect cable to lever (9).
23. Connect all hydraulic hoses.

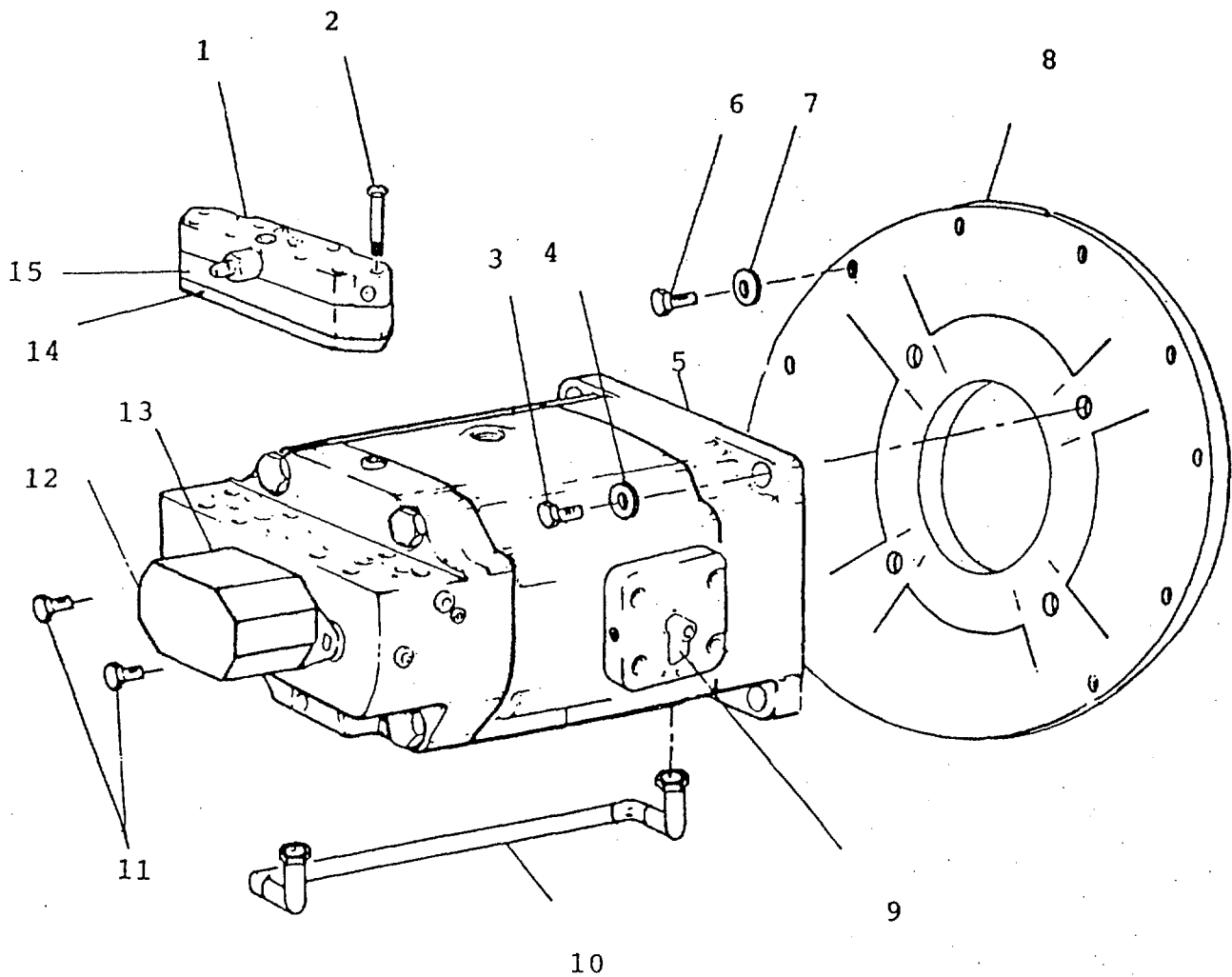

Figure 5-22. Hydraulic Pump Assembly

5-26. REPAIR CONTROL PANEL ASSEMBLY

This Task Covers: a. Repair

INITIAL SETUP

Tools Required

Tool Kit, General Mechanics
(Appendix B, Item 1)
Tool Kit, Automotive
(Appendix B, Item 3)

Materials/Parts Required

Cotton Rags (Appendix E,
Item 3)
Screw P/N NAS1100-E-08-10
Washer P/N MS35338-138
Nut P/N MS25082-C2
Washer P/N MS51412-1
Fire Extinguisher
P/N P01004
Frame P/N D100425
Lever P/N B100431
Screw P/N NAS1100-E-5-8
Knob P/N 7M706
Screw P/N MS90728-60
Washer P/N MS35338-46
Nut P/N MS25082-20
Valve P/N 211-1038
Nut P/N 21084-000
Steering Wheel P/N 5W32166
Bearing P/N 4X727
Adapter P/N 8-8 070120C4
Grommet P/N P05044
Lever P/N C100430
Set Screw P/N MS51021-57
Valve P/N RD516CA5A4F1
Tachometer P/N TH91
Gage P/N P03041
Gage P/N P03042
Gage P/N P03043
Gage P/N P03044
Gage P/N P03045
Thermometer P/N 53215P
Meter P/N 52435P025
Gage P/N 53932P
Ammeter P/N 53930P
Switch P/N P01018
Switch P/N 1S16968
Alarm P/N 366-TJ

Equipment Conditions

Engine Shutdown (para 2-11).
Battery Disconnected (para 4-58).

Personnel Required

1 Person

Fuse Holder P/N 1A17537
 Fuse P/N F02B32V20A
 Switch P/N 1S16970
 Light P/N P04208
 Hose Assembly
 P/N J4HU0810RC9008MC-120
 Hose Assembly
 P/N J4H0810RC10NJ90T-120
 Hose Assembly
 P/N J4HU0810RC9008MC-90
 Hose Assembly
 P/N J4HU0812RC08NJ90T-9
 Hose Assembly
 P/N J4HU0406NJ06NJ90T-30
 Hose Assembly
 P/N E7HU1212RC12MC-100
 Hose Assembly
 P/N E7HU0406NJ02MB-102
 Hose Assembly
 P/N E7HU0406NJ02MB-132
 Hose Assembly
 P/N J4HU0808NJ08RC-180
 Hose Assembly
 P/N E7HU0406NJ06RA-132
 Hose Assembly
 P/N J4HU0406NJ04RA-132
 Hose Assembly
 P/N J4HU0808RC12NJ-180
 Elbow P/N 849-FS-08X12
 Valve P/N 606-1213
 Clamp P/N M-90
 Hose P/N P11034
 Screw P/N MS3507-367
 Adapter P/N 2022-4-6S
 Elbow P/N MS515121-A6Z
 Screw P/N NAS1100-E-3-16
 Nut P/N MS25082-C3
 Washer P/N MS35338-13
 Screw P/N MS90728-62
 Inverter P/N P04209
 Washer P/N MS51412-7

REPAIR (Figure 5-23.)

1. Repair is limited to the replacement of defective components.
2. Remove bolts (4), nuts (8) and washers (5) and (7), from angle support (6).

3. Remove bolts (24) and washers (23) and remove fire extinguisher (22) and angle bracket (21).
4. Remove rear panel (25) by removing bolts (26).
5. Remove knob (19).
6. Remove nuts (13) and bolts (17) from bearings (16).
7. Remove bolts (20) from side panel (15).
8. Slide side panel (15) from main panel over lever arm (18).
9. Remove set screws (34) from collar (30) and pull lever (18) from assembly.
10. Remove cap (10), nut (9) and pull off steering wheel (11).
11. Disconnect all hoses from valve (12).
12. Remove bolts (14) and remove valve (12).
13. To remove gauges (1) typical, loosen and remove nut (3), slip off bracket (2), disconnect electric wire or hydraulic hose and remove gauge (1).
14. Loosen and remove bolts (35), washers (36), and nuts (29).
15. Remove screws (28) from angle clips (27) and remove power inverter (38).
16. Loosen and remove bolts (32) and washers (31).
17. Remove servo (power steering) valve (33) from frame.
18. Install servo valve (33).
19. Install and tighten washer (31) and bolts (32).
20. Install power inverter (38).
21. Install angle clips (27) and screws (28).
22. Install and tighten washers (36), bolts (35) and nuts (29).
23. Reinstall gauges typically by installing bracket (2), tightening nut (3) and reconnecting electric wire or hydraulic hose.
24. Install valve (12).
25. Install and tighten bolts (14).
26. Connect hoses to valve (12).

27. Install steering wheel (11).
28. Install nut (9) and cap (10).
29. Install lever (18).
30. Install collar (30) and tighten set screw (34).
31. Install side panel (15).
32. Install bolts (20).
33. Install bearings (16).
34. Install bolts (17) and nuts (13).
35. Install knob (19).
36. Install rear panel (25).
37. Install bolts (26).
38. Install bracket (21).
39. Install washers (23) and bolts (24).
40. Install fire extinguisher (22).
41. Install angle support (21).
42. Install bolts (4), washers (5), and nuts (8).

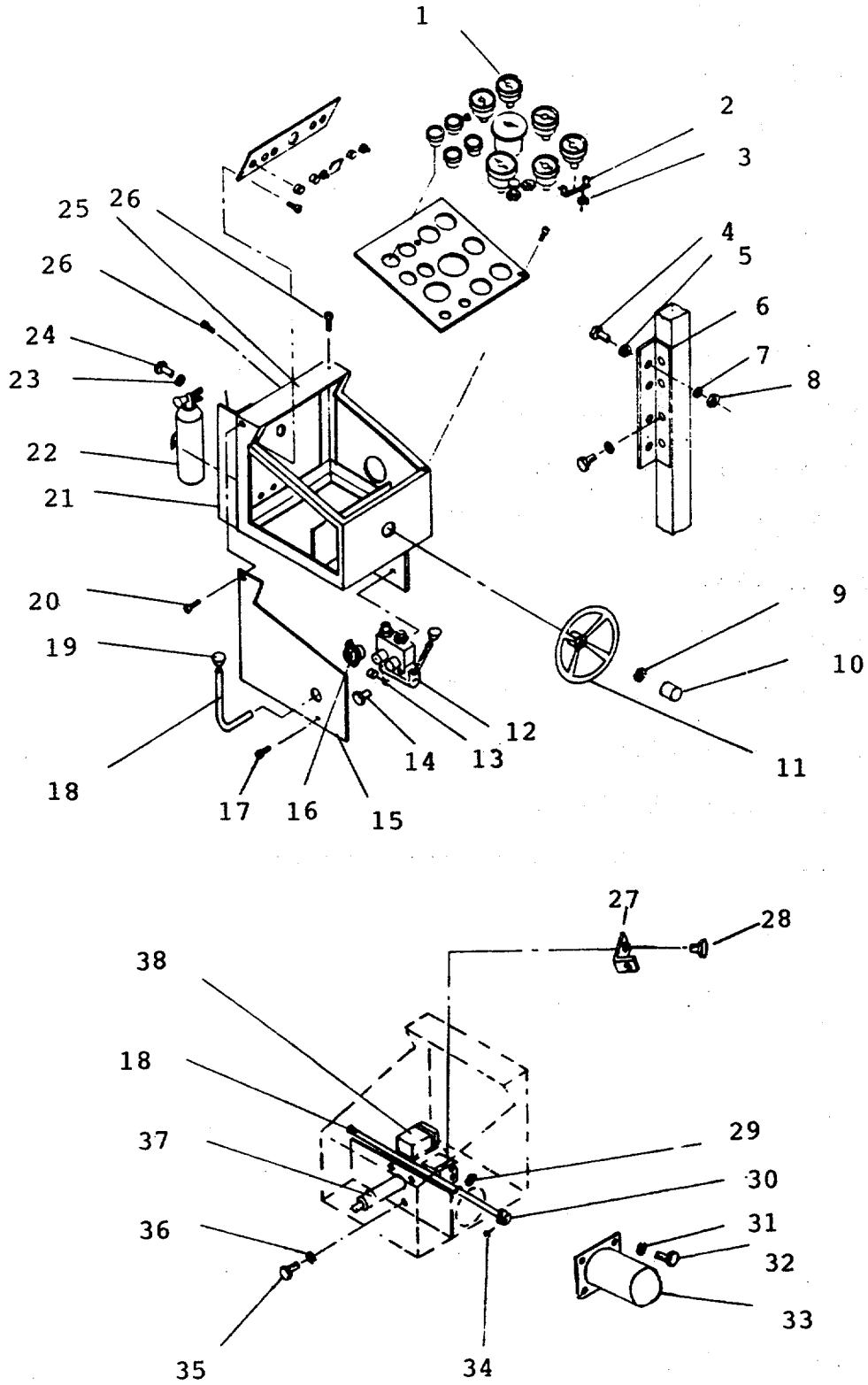

Figure 5-23. Control Panel Assembly

5-27. REPAIR HEAT EXCHANGER ASSEMBLY (HYDRAULIC OIL)

This Task Covers: a. Repair

INITIAL SETUPTools Required

Tool Kit, General Mechanics
(Appendix B, Item 1)

Equipment Conditions

Engine Shutdown (para 2-11).
Battery Disconnected (para 4-58).
Exchanger Removed (para 4-53).

Materials/Parts Required

Cotton Rags (Appendix E,
Item 3)
Gasket P/N 3-299-8-03-113-01
Bolt P/N P07156
Core Assembly
P/N 4-441-03-048-032
Screw P/N 2-170-5-05-901-07
Anode P/N 3-386-9-03-101-02
Screw P/N 2-170-5-05-901-08

Personnel Required

1 Person

REPAIR (Figure 5-24.)

1. Repair is limited to the replacement of defective parts.
2. Remove screws (2).
3. Remove bonnets (3).
4. Remove gasket (1).
5. Remove tubes (4).
6. Install tubes (4).
7. Install new gasket (1).
8. Install bonnets (3).
9. Install screws (2).

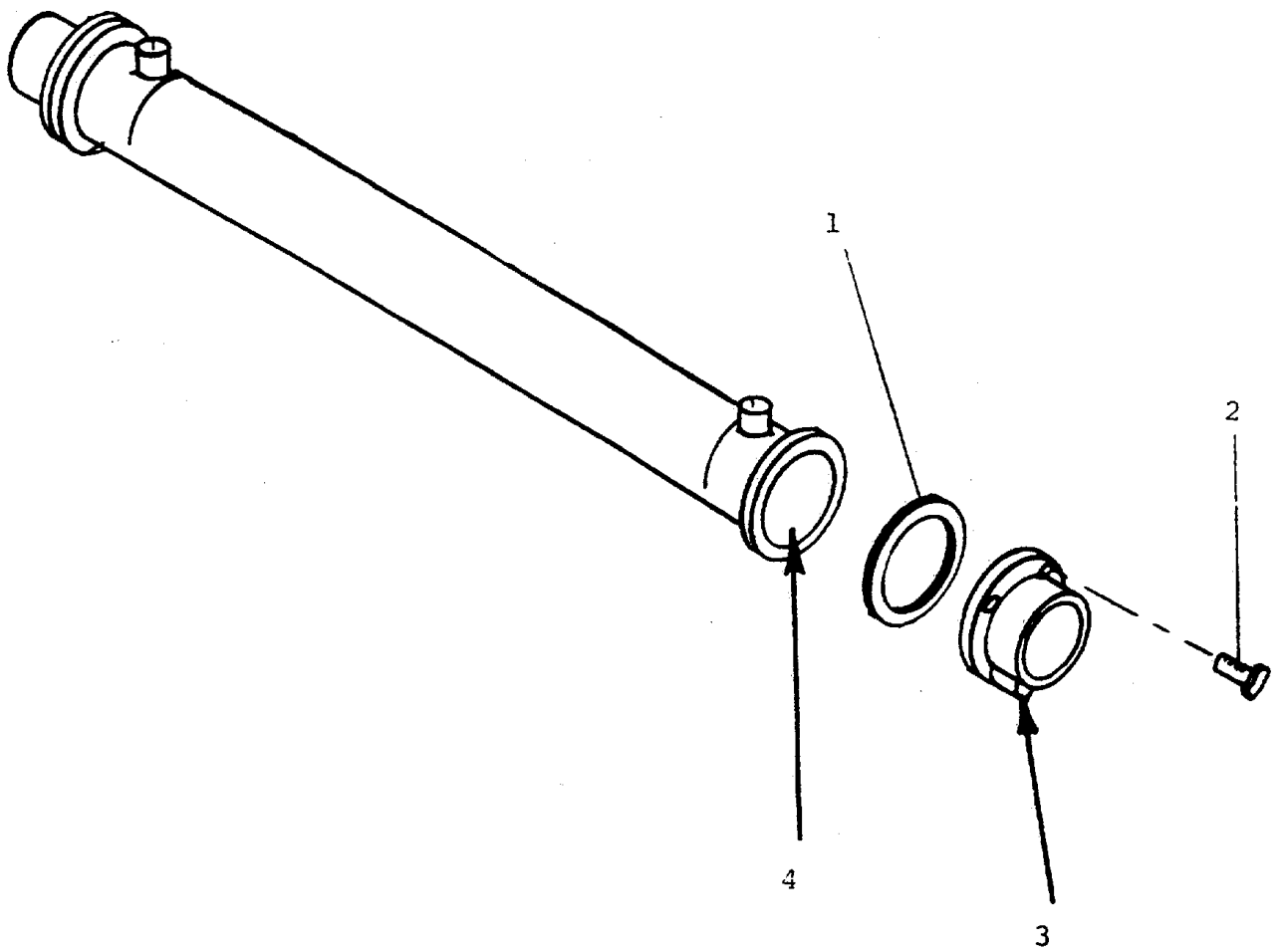

Figure 5-24. Heat Exchanger Assembly

5-28. REPAIR/REPLACE ELECTRICAL WIRING ASSEMBLY

This Task Covers: a. Repair b. Replacement

INITIAL SETUP**Tools Required**

Tool Kit, General Mechanics
(Appendix B, Item 1)

Materials/Parts Required

Cotton Rags (Appendix E,
Item 3)
Electric Cable Assembly
P/N P04010

Equipment Conditions

Engine Shutdown (para 2-11).
Battery Disconnected (para 4-58).

Personnel Required

1 Person

REPAIR Repair is limited to the replacement of the entire harness if defective.

REPLACEMENT (Figure 5-25.)

NOTE

When removing harness, tag or mark each terminal connection as it is disconnected.

1. Tag and remove terminal connections.
2. Remove all harness retaining brackets.
3. Remove harness assembly.
4. Install harness assembly.
5. Install all harness retaining brackets.
6. Install terminal connections and remove tags.

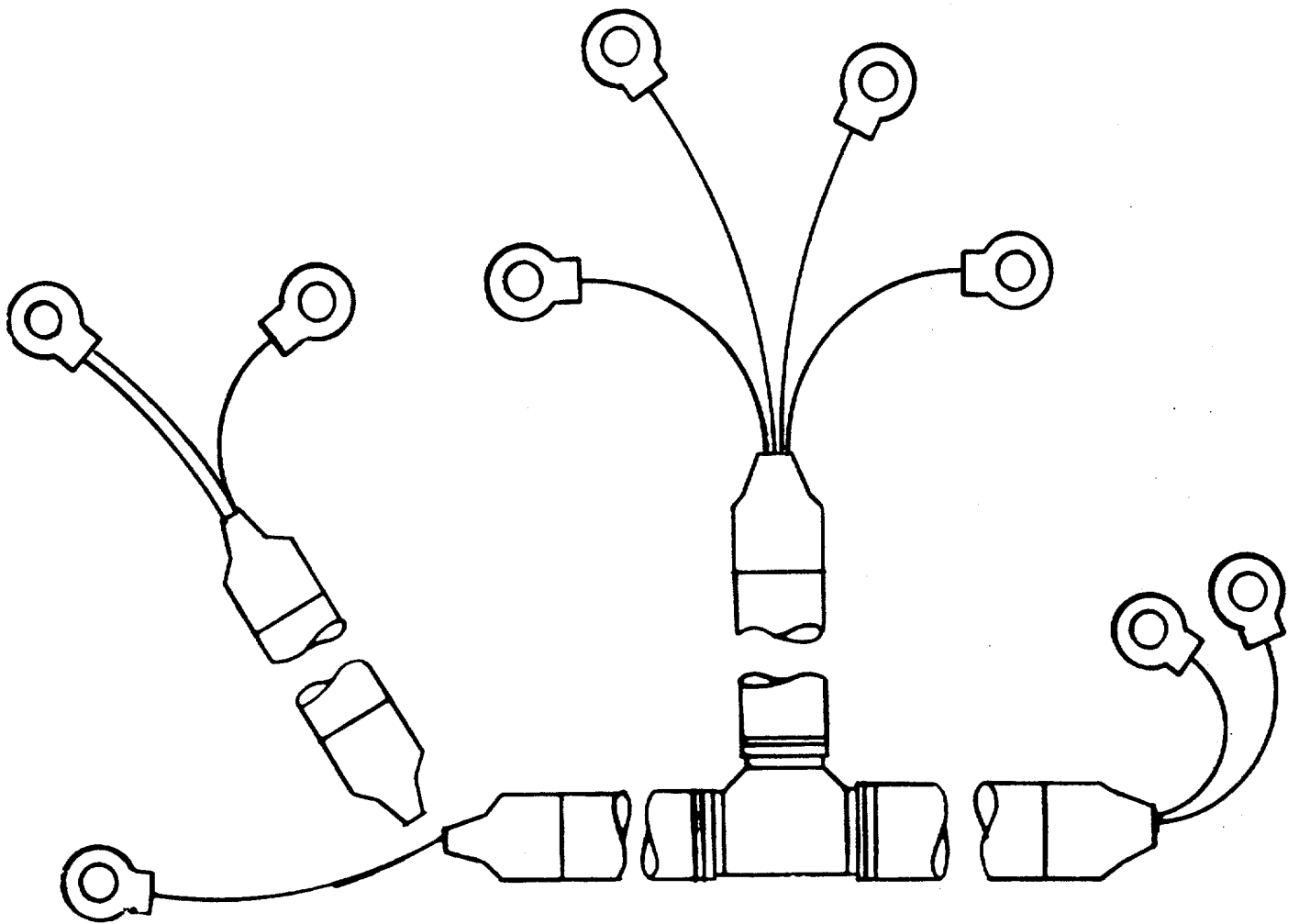

Figure 5-25. Electrical Wiring Assembly

5-29. REPAIR/REPLACE HYDRAULIC HOSE AND VALVE ASSEMBLY

This Task Covers: a. Repair b. Replacement

INITIAL SETUP
Tools Required

Tool Kit, General Mechanics
(Appendix B, Item 1)

Equipment Conditions

Engine Shutdown (para 2-11).
Battery Disconnected (para 4-58).
Reservoir Valve Closed
(L05-2010-205-12).

Materials/Parts Required

Cotton Rags (Appendix E,
Item 3)
Masking Tape (Appendix E,
Item 8)
Elbow P/N 849FS-16X16
Hose Assembly
P/N L1HU1616NJ16NJ-46
Hose Assembly
P/N L1HL1 61 6NJ1 6NJ90T-44
Elbow P/N 849-FSO-16X16
Valve P/N RQIB-LAN-IEM
Adapter P/N 6405-16
Tee P/N 25VC-16
Adapter P/N 6401-16
Valve
P/N FB1-XOHP-156N-45-10
Valve
P/N FB1-XOHP-156N-7-10
Hose Assembly
P/N L1HU1616NJ16NJ-34
Elbow P/N 849-FS-06X04
Hose Assembly
P/N J4HU0608NJ06NJ90TL-20
Cross P/N 852-FS-16
Adapter P/N 883-FS-16X12
Hose Assembly
P/N J4HU081 2NJ08NJ90T-20
Tee P/N 851-FS-08X06
Tee P/N 25VK-06
Tee P/N 845-FS-08X06
Valve P/N MF370CS
Hose Assembly
P/N E7HU1616MC16NJ-34
Elbow P/N 849-FSO-16X20
Hose Assembly
P/N E7HU1616NJ16NJ-18
Adapter P/N 849-FS-16X20

Personnel Required

1 Person

MATERIAL/PARTS REQUIRED

Tee P/N 2605-16-20
 Hose Assembly
 P/N J4HU1216NJ9016NJ-60
 Hose Assembly
 P/N E7HU0404RC04NJ-48
 Hose Assembly
 P/N E7HU1616NJ16NJ-32
 Valve P/N P16002
 Hose Assembly
 P/N U2EL2020NJ20NJ-19
 Adapter P/N 2605-20-24
 Adapter
 P/N U2EL2020NJ20NJ-27
 Adapter P/N 879-FS-20
 Hose Assembly
 P/N 841-FS-20
 Hose Assembly
 P/N 871-FS-12
 Filter
 P/N MPSG250-S-P10-A6S
 Hose Assembly
 P/N E7HU0406NJ02MB-132
 Elbow PFN P10171
 Bushing P/N P10057
 Hose Assembly
 P/N E7HU0406NJ02MB-102
 Elbow P/N 849-FSO-04X04

REPAIR Repair is limited to the replacement of defective parts.

REPLACEMENT (Figure 5-26.)

NOTE

Hose lines are rated for continuous operation at maximum operating pressure (one fourth the hose minimum burst pressure).

NOTE

Hoses are resistant to mildew, cleaning solvents, oils and fuels.

NOTE

Before disconnecting any hose, fitting, or valve, clean connection and adjacent area.

NOTE

Immediately after disconnecting any hose assembly, tag or mark connection to insure proper reassembly.

NOTE

As soon as a disconnection is made, tape or plug open connections.

NOTE

Be sure parts reinstalled are clean prior to reassembly.

NOTE

Keep all new parts in their containers until ready to use.

NOTE

Hoses should be stored in a dark, dry atmosphere away from electrical equipment. The temperature should not exceed 90 degrees.

1. Loosen and remove connections.
2. Remove hose assembly.

NOTE

It is recommended to remove and replace one (1) hose assembly completely before removing a second.

3. Install hose assembly.
4. Tighten hose end connections.

CAUTION

Removal and installation of O-ring fittings requires care to prevent damage to the O-ring or leaks may result.

5. Disconnect assembly (1).

6. Loosen locknut (6).
7. Unscrew fitting (2).
8. Put locknut (6), backup washer (3), and O-ring seal (5) as far back on fitting body (2) as possible.
9. Turn fitting body (2) into position until washer (3) makes contact with part (4).
10. Rotate fitting body (2) to orientate connection (1).
11. Tighten locknut (6).
12. Make connection (1).

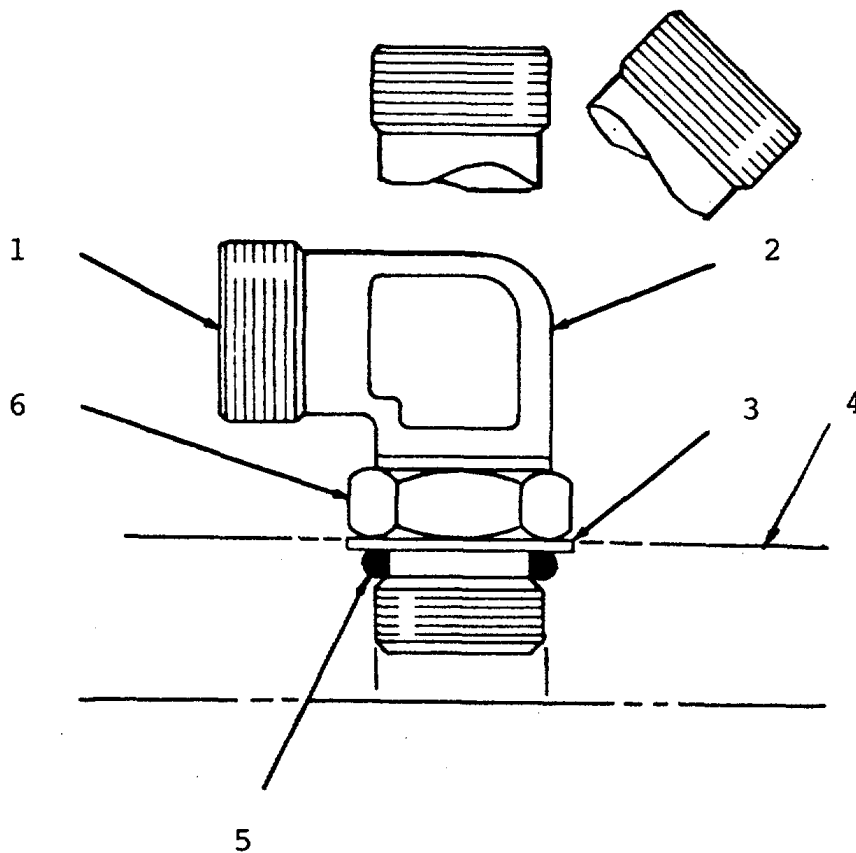

Figure 5-26. Hydraulic Hose and Valve Assembly

5-30. REPAIR/REPLACE UPPER OUTDRIVE HOUSING ASSEMBLY

This Task Covers: a. Repair b. Replacement

INITIAL SETUP
Tools Required

Tool Kit, General Mechanics
(Appendix B, Item 1)

Equipment Conditions

Engine Shutdown (para 2-11).
Battery Disconnected (para 4-58).
Lift Cylinders Removed
(para 5-32).

Materials/Parts Required

Cotton Rags (Appendix E,
Item 3)
Cover P/N D100314
Cover P/N D100315
Swivel P/N 69520FB20-FB20
Swivel P/N 9S12J12-012
Swivel P/N 9S6J8-08
Packing P/N P05055
Packing P/N P05053
Hose Assembly
P/N J4HU1212RC9010NJ-18
Adapter P/N 849-FSO-10X10
Packing P/N P05054
Hose Assembly
P/N J4HU1212RC99012RC90-14.5-190
Tube P/N C100353
Swivel Assembly
P/N D100326
Hose Assembly
P/N J4HU0808RC9010RC90-10.5-30
Hose Assembly
P/N JHU0808RC9010RC90-25.5-300
Fitting P/N P10004
Plug P/N P10007
Cap P/N MS25043-18D
Connector
P/N MS3102R-18-12S
Motor P/N RE240804
Key P/N P06002
Link P/N P08043
Chain P/N P08042
Shaft P/N C100324
Indicator P/N P04130
Cylinder Assembly
P/N TH5036048PA-00
Packing P/N 10033
Cup P/N 10026

Personnel Required

3 Persons

Packing P/N 10055
Retainer P/N 10085
Ring P/N 10714
Seal P/N 10008

REPAIR Repair is limited to the replacement of defective parts.

REPLACEMENT (Figure 5-27.)

1. Loosen and remove bolts (5) and washers (6).
2. Remove back cover (4).
3. Disconnect hoses (14), (8), (12), and (13).
4. Loosen and remove bolts (10) and washers (9).
5. Separate upper outdrive housing assembly (7) from lower section (11).
6. Remove O-ring (15).
7. Remove position indicator (para 4-50).
8. Loosen and remove bolts (2) and washers (3).
9. Remove top cover (1).
10. Loosen and remove bolts (16).
11. Remove screw (19) and washer (18) to remove fitting (17).
12. Remove seals (20) and (21).

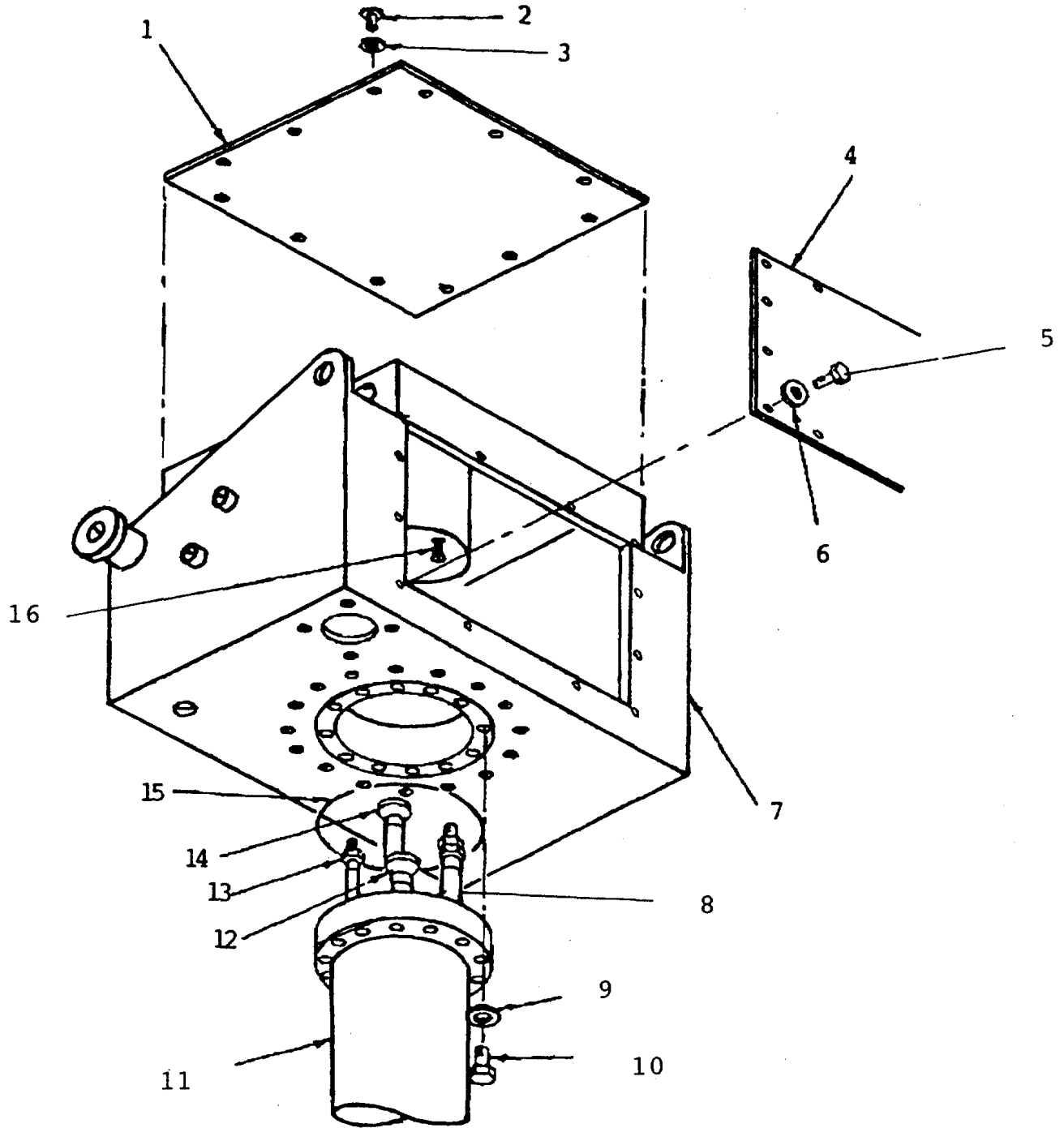

Figure 5-27 (1 of 3). Upper Outdrive Housing Assembly

REPLACEMENT

13. Loosen and remove bolts (23) and washers (22).
14. Loosen and remove screws (26) and washers (25).
15. Remove protective cover (27) and bearing (28).
16. Remove steering motor assembly (para 4-49).
17. Remove pinion (29).
18. Remove drain plug (30).
19. Remove swivels (31) and (32).
20. Loosen and remove bolts (33) and washers (34) to remove plate (35).
21. Loosen and remove bolts (36) and (43) and washers (37) and (42) to remove tubing assemblies (41).
22. Remove hoses (44) and (46).
23. Pull swivel stator (45) from rotor (38).
24. Remove four seals (40) and two bearings (39).
25. Loosen and remove bolts (53) and washers (52) to remove retainer plate (51).
26. Loosen and remove bolts (50) and washers (49).
27. Adapter (48) and gear (47) can now be removed.
28. Install gear (47) and adapter (48).
29. Install bolts (50) and washers (49).
30. Install retainer plate (51).
31. Install washers (52) and bolts (53).
32. Install bearings (39) and seals (40).
33. Install rotor (38) into stator (45).
34. Install hoses (44) and (46).
35. Install tubing assemblies (41).
36. Install washers (37) and (42) and bolts (36) and (43).

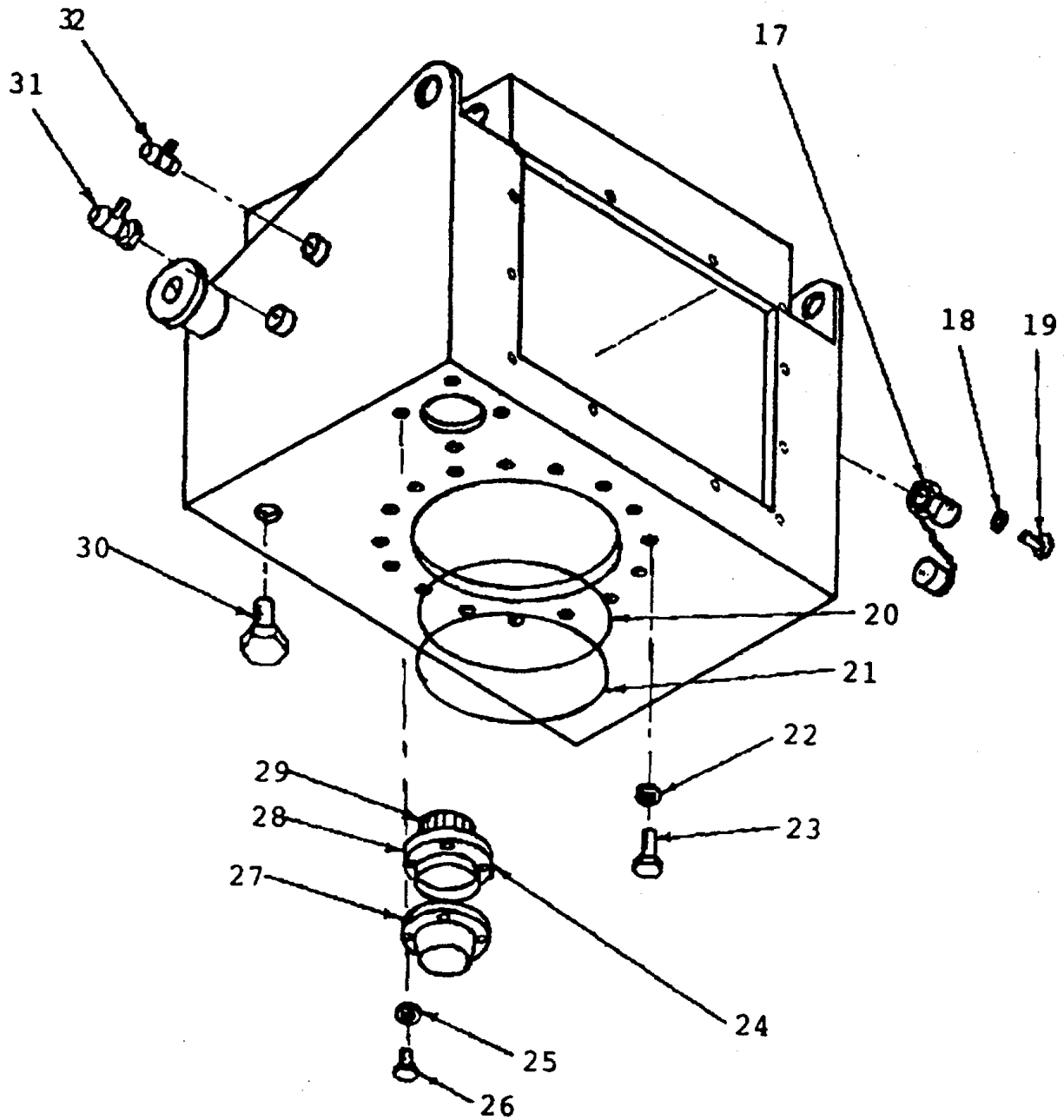

Figure 5-27. (2 of 3). Upper Outdrive Housing Assembly

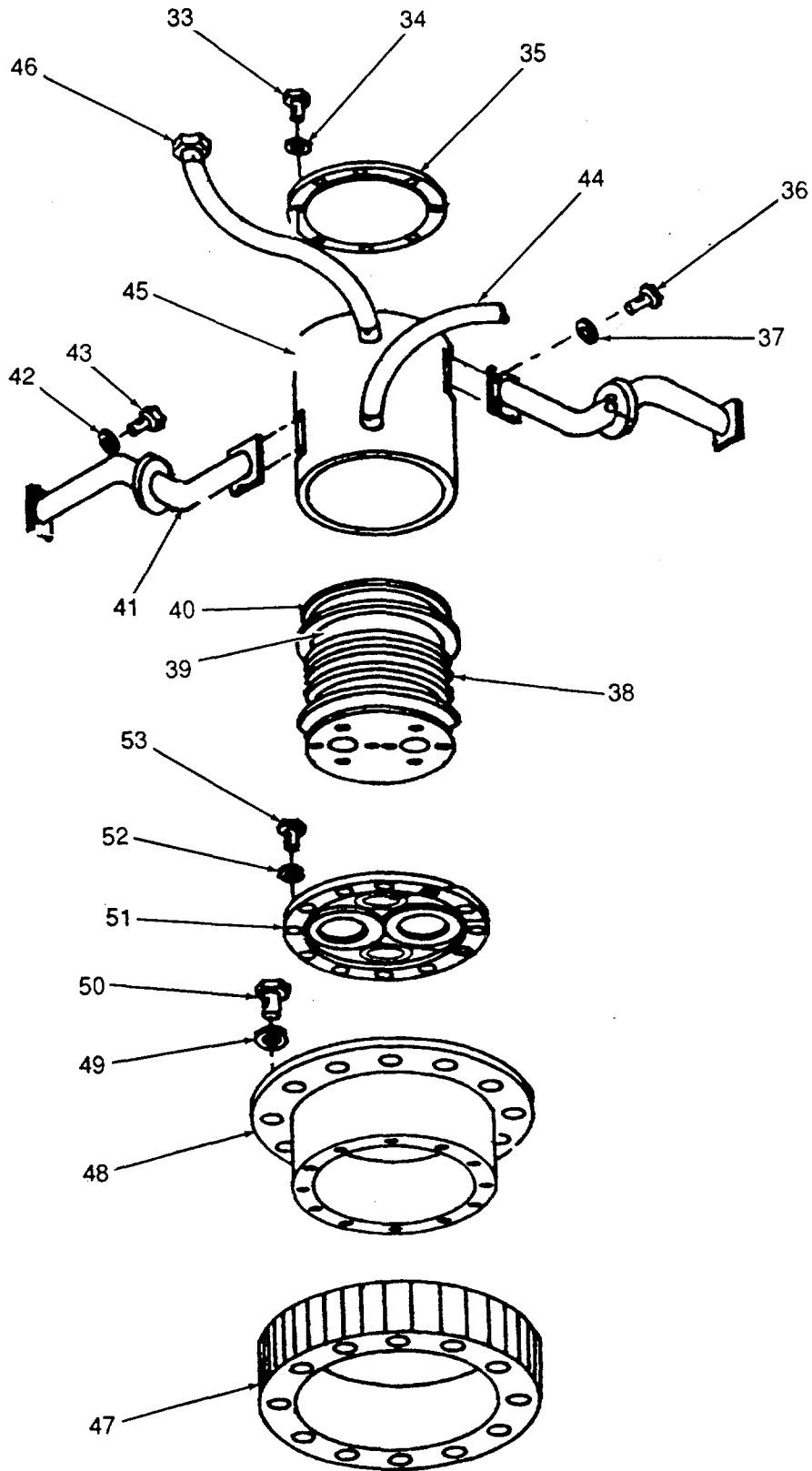

Figure 5-27 (3 of 3). Upper Outdrive Housing Assembly

REPLACEMENT

37. Install plate (35).
38. Install washers (34) and bolts (33).
39. Install swivels (31) and (32).
40. Install drain plug (30).
41. Install pinion (29).
42. Install steering motor (para 4-49).
43. Install cover (27) and bearing (28).
44. Install washers (25) and screws (26).
45. Install washers (22) and bolts (23).
46. Install seals (20) and (21).
47. Install fitting (17).
48. Install washer (18) and screw (19).
49. Install bolts (16).
50. Install top cover (1).
51. Install washers (3) and bolts (2).
52. Install position indicator (para 4-50).
53. Install O-ring (15).
54. Position housing (7) and lower section (11) together.
55. Install washers (9) and bolts (10).
56. Connect hoses (8, 12, 13, and 14).
57. Install back cover (4).
58. Install washers (6) and bolts (5).

5-31. REPAIR/REPLACE LOWER UNIT ASSEMBLY

This Task Covers: a. Repair b. Replacement

INITIAL SETUP
Tools Required

Tool Kit, General Mechanics
(Appendix B, Item 1)
Socket Wrench (Appendix B,
Item 1)
Crescent Wrench (Appendix B,
Item 1)
Special Puller (Appendix B,
Item 1)
Nylon Strap

Equipment Conditions

Engine Shutdown (para 2-11).
Battery Disconnected (para 4-58).
Upper Housing Removed
(para 5-30).

Materials/Parts Required

Cotton Rags (Appendix E,
Item 3)
Packing P/N 2-278
Adapter P/N 848-FSO-12X12
Hose Assembly
P/N E7HU081 0RCNJ-84
Packing P/N P05054
Hose Assembly
P/N N6ER202PH24PH-77
Packing P/N P05016
Pin P/N P06001
Propeller P/N D100410
Key P/N P06000
Seal P/N D100300
Fitting P/N P10004
Packing P/N 2-245
Seal P/N 12494LPD
Seal P/N 15672HP
Packing P/N 2-278
Hose Assembly
P/N 10CIT-12FJX-8MP-98
Motor P/N D100408
Packing P/N 2-262
Coupling P/N C100407
Packing P/N C100414
Packing P/N P05050
Shim P/N K22005
Shim P/N K22007
Cong P/N HM813849
Shaft P/N D100299
Cover P/N D100314
Cover P/N D100310

Personnel Required

2 Persons

MATERIAL/PARTS REQUIRED

Swivel

P/N 69520FB20-FB20

Swivel P/N 9S12J12-012

Swivel P/N 9S6J8-08

Packing P/N P05055

Packing P/N P05053

Hose Assembly

P/N J4HU1212RC9010NJ-18

Adapter P/N 849-FSO-10X10

Packing P/N P05054

Hose Assembly

P/N J4HU1212RC9012RC90-14.5-190

Tube P/N C100353

Swivel Assembly P/N D100326

Hose Assembly

P/N J4HU0808RC9010RC90-10.5-30

Hose Assembly

P/N J4HU0808RC9010RC90-25.5-300

Fitting P/N P1004

Plug P/N P10007

Cap P/N MS25043-18D

Connector P/N MS3102R-18-12S

Motor P/NRE240804

Key P/N P06002

Link P/N P08043

Chain P/N P08042

Shaft P/N C100324

Indicator P/N P04130

Cylinder Assembly

P/N TH5036048PA-00

Packing P/N 10033

Cup P/N 10026

Packing P/N 10053

Retainer P/N 10085

Ring P/N 10714

Seal P/N 10008

REPAIR Repair is limited to the replacement of defective parts.REPLACEMENT (Figure 5-28).

1. Loosen and remove bolts (1).
2. Remove outdrive stem (2) using hoist and nylon strap.
3. Using special crescent wrenches, disconnect hose (3) and hose (4).
4. Using special socket wrench, disconnect hose (5).
- 5.
- 6.
- 7.
- 8.
- 9.

REPLACEMENT

5. Cover hose ends with tape or other material to prevent contamination.
6. Remove cotter pin (26).
7. Remove jam nut (25) and prop nut (24).
8. Remove propeller (23) using special puller tool and key (6).
9. Remove bolts (22) and rope guard/seal assembly (21). Use tapped back-off holes if necessary.
10. Remove seals (7) and (8) from seal housing (21).
11. Remove bolts (9) and lockwashers (10) from bearing housing (20).
12. Remove complete power module assembly from lower housing.
13. Remove bolts (28) and lockwasher (27). Pull assembly apart.
14. Remove bolts (18) and washers (17).
15. Remove O-ring (38).
16. Pull prop shaft (13) from assembly.
17. Remove bearing retaining ring (16), shims (15) and bearings (14), (outer race).
18. Press bearing (19) (inner race) off shaft.
19. Press bearing (12) (inner race) off shaft (13).
20. Tap bearing (11) (outer race) from housing (20).
21. Remove bolts (32) and lockwashers (31) from motor (33).
22. Remove bolts (30) and lockwashers (29) from flange (35) and gear (37).
23. Remove O-ring (34), and gasket (36).
24. Replace O-ring (34), and gasket (36).
25. Install bolts (30) and lockwashers (29) into flange (35) and gear (37).
26. Install lockwashers (31) and bolts (32) into motor (33).
27. Install bearing (11) (outer race) onto housing (20).
28. Press bearing (12) (inner race) onto shaft (13).
29. Press bearing (19) (inner race) onto shaft.
- 30.
- 31.
- 32.
- 33.
- 34.

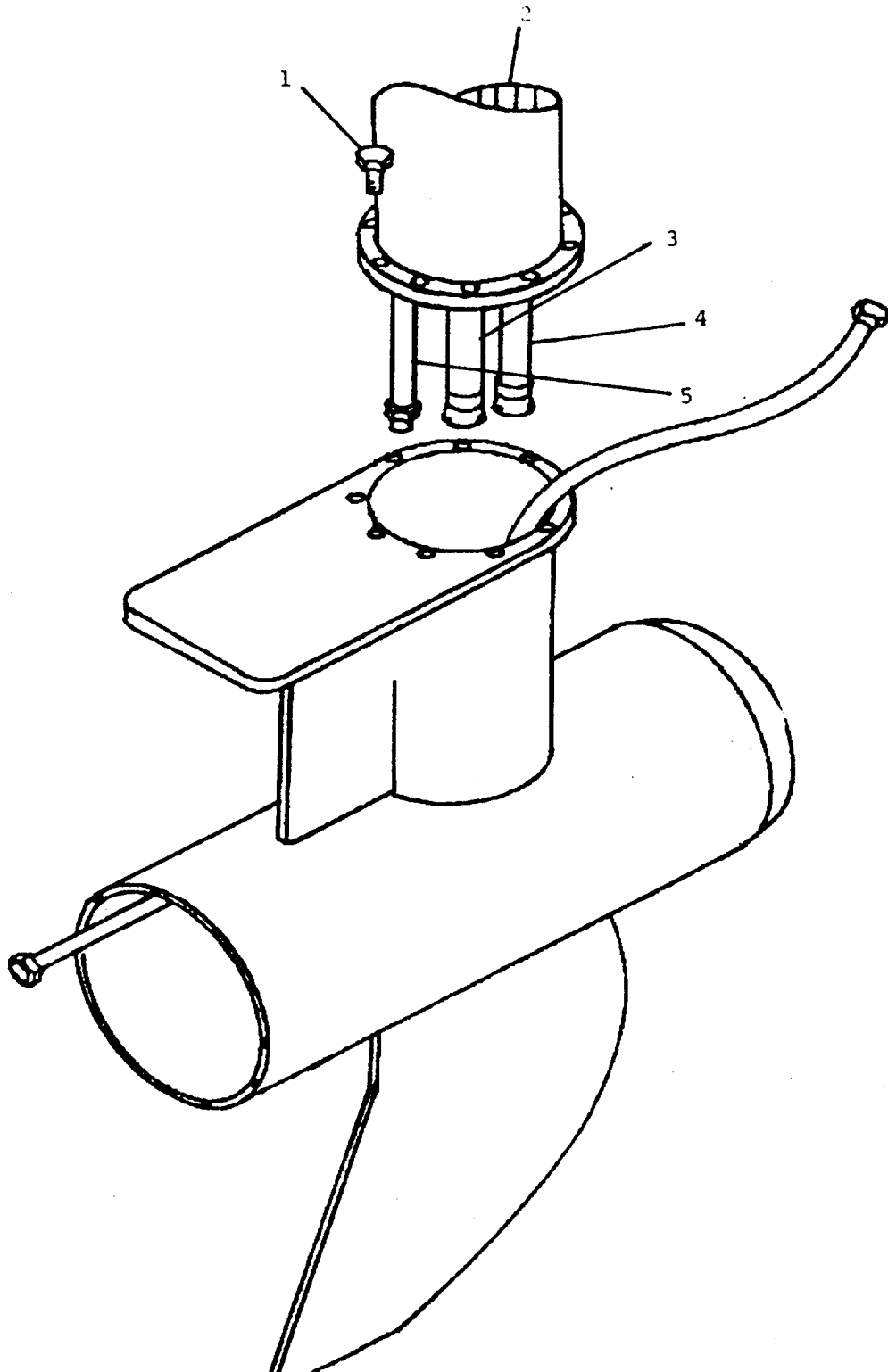

Figure 5-28 (1 of 3). Lower Unit Assembly

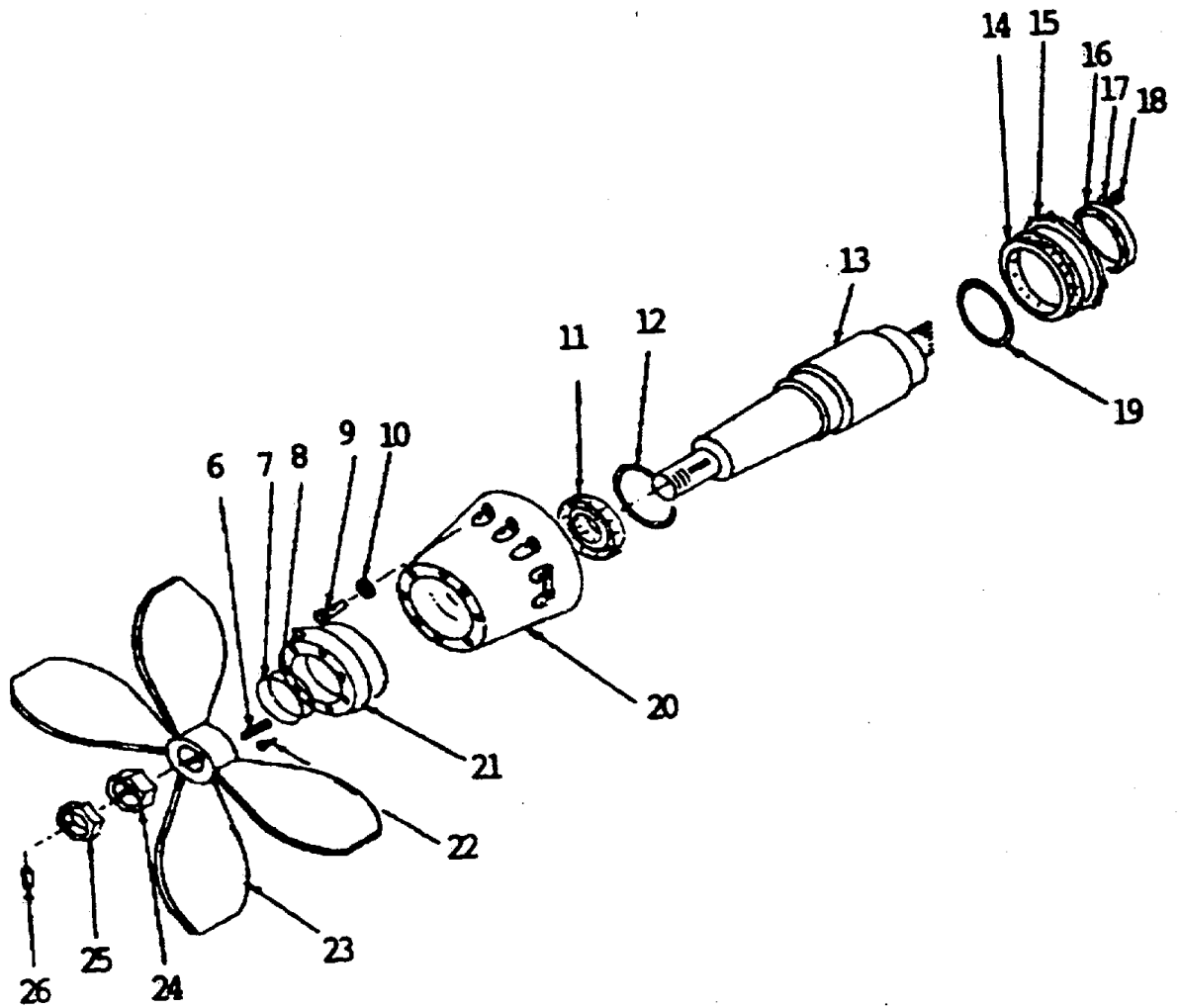

Figure 5-28 (2 of 3). Lower Unit Assembly

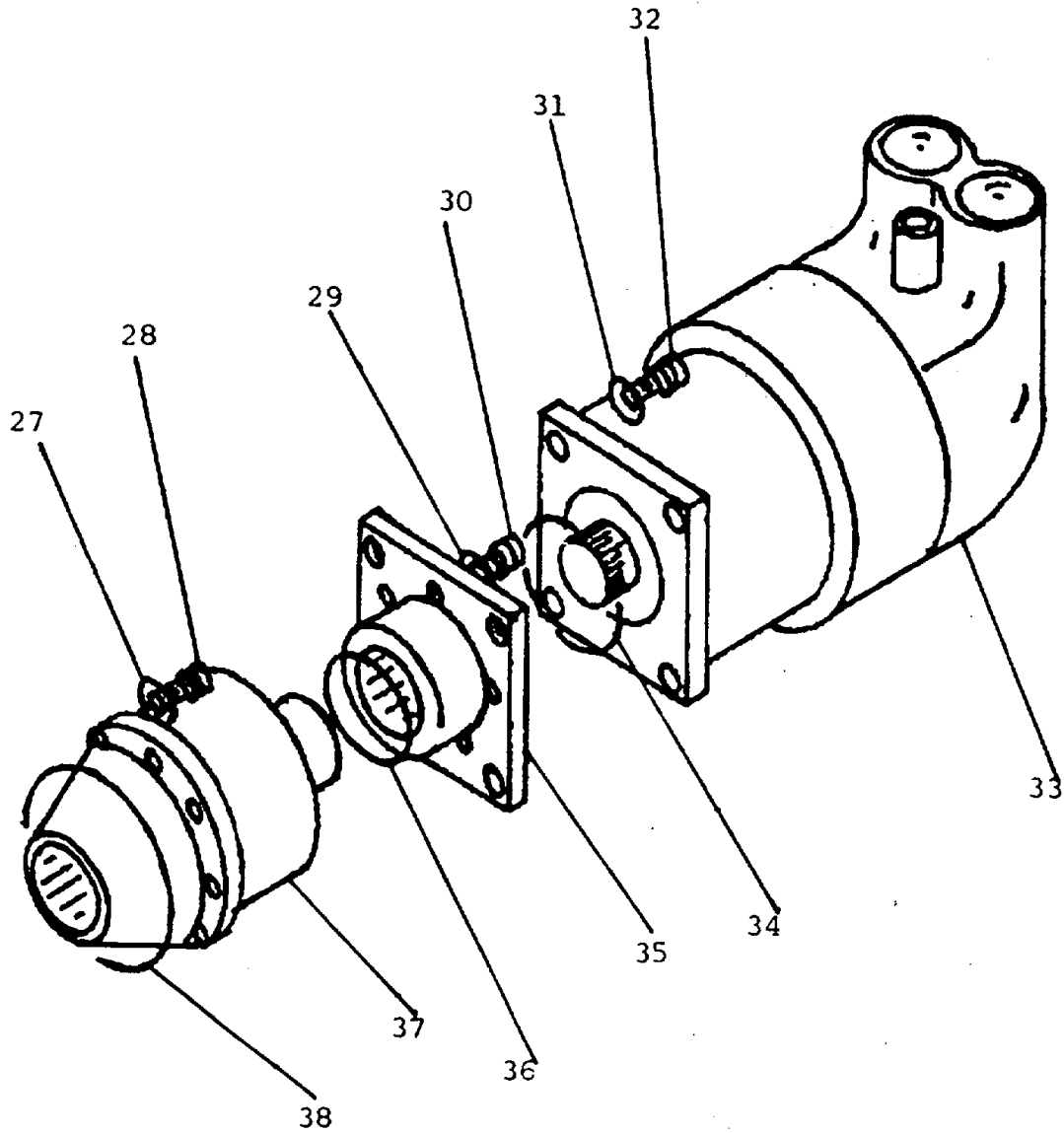

Figure 5-28 (3 of 3). Lower Unit Assembly

REPLACEMENT

30. Install bearing outer race (19).
31. Install shims (15).
32. Install retaining ring (16).
33. Install propeller shaft assembly.
34. Install O-ring (38).
35. Install washers (17) and bolts (18).
36. Install lockwashers (27) and bolts (28).
37. Install complete assembly into lower housing.
38. Install lockwashers (10) and bolts (9) into housing (20).
39. Install seals (7) and (8) into housing (21).
40. Install assembly (21).
41. Install bolts (22).
42. Install key (6).
43. Install propeller.
44. Install prop nut (24) and jam nut (25).
45. Install cotter pin (26).
46. Connect hose (5).
47. Connect hoses (3) and (4).
48. Position outdrive stem (2) onto lower unit.
49. Install and tighten bolts (1).

5-32. REPLACE LIFT CYLINDER ASSEMBLY

This Task Covers: a. Replacement

INITIAL SETUP

Tools Required

Tool Kit, General Mechanics
(Appendix B, Item 1)
Hoist

Equipment Conditions

Engine Shutdown (para 2-11).
Battery Disconnected (para 4-58).

Materials/Parts Required

Cotton Rags (Appendix E,
Item 3)
Cylinder Assembly
P/N TH5036048PA-00
Packing P/N 10033
Cup P/N 10026
Packing P/N 10055
Retainer P/N 10085
Ring P/N 10714
Seal P/N 10008

Personnel Required

2 Persons

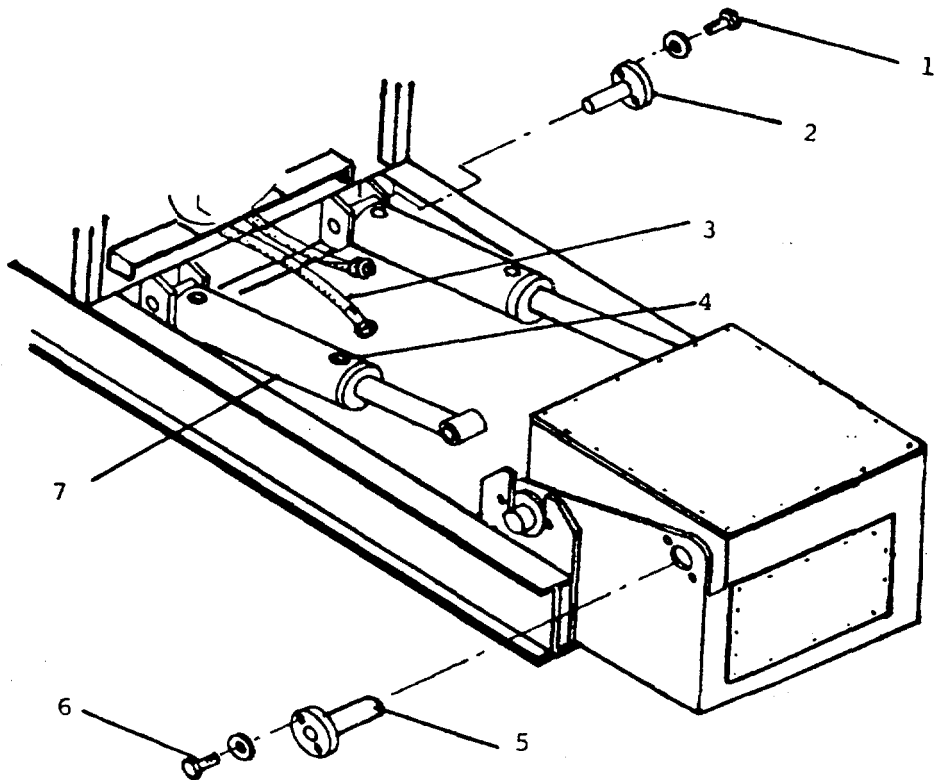

Figure 5-29. Lift Assembly

REPLACEMENT**NOTE**

Cover ends of hoses and cylinder ports immediately upon disconnecting hoses.

1. Disconnect hoses (3) from cylinder (4).
2. Remove bolts (6). Use hoist and fasten strap around cylinders.
3. Support.
4. Remove pin (5).
5. Loosen and remove bolts (1).
6. Pull and remove pin (2).
7. Remove cylinder assembly (7).
8. Install cylinder assembly (7).
9. Install pin (2).
10. Install and tighten bolts (1).
11. Install pin (5).
12. Install bolts (6).
13. Install hoses (3).

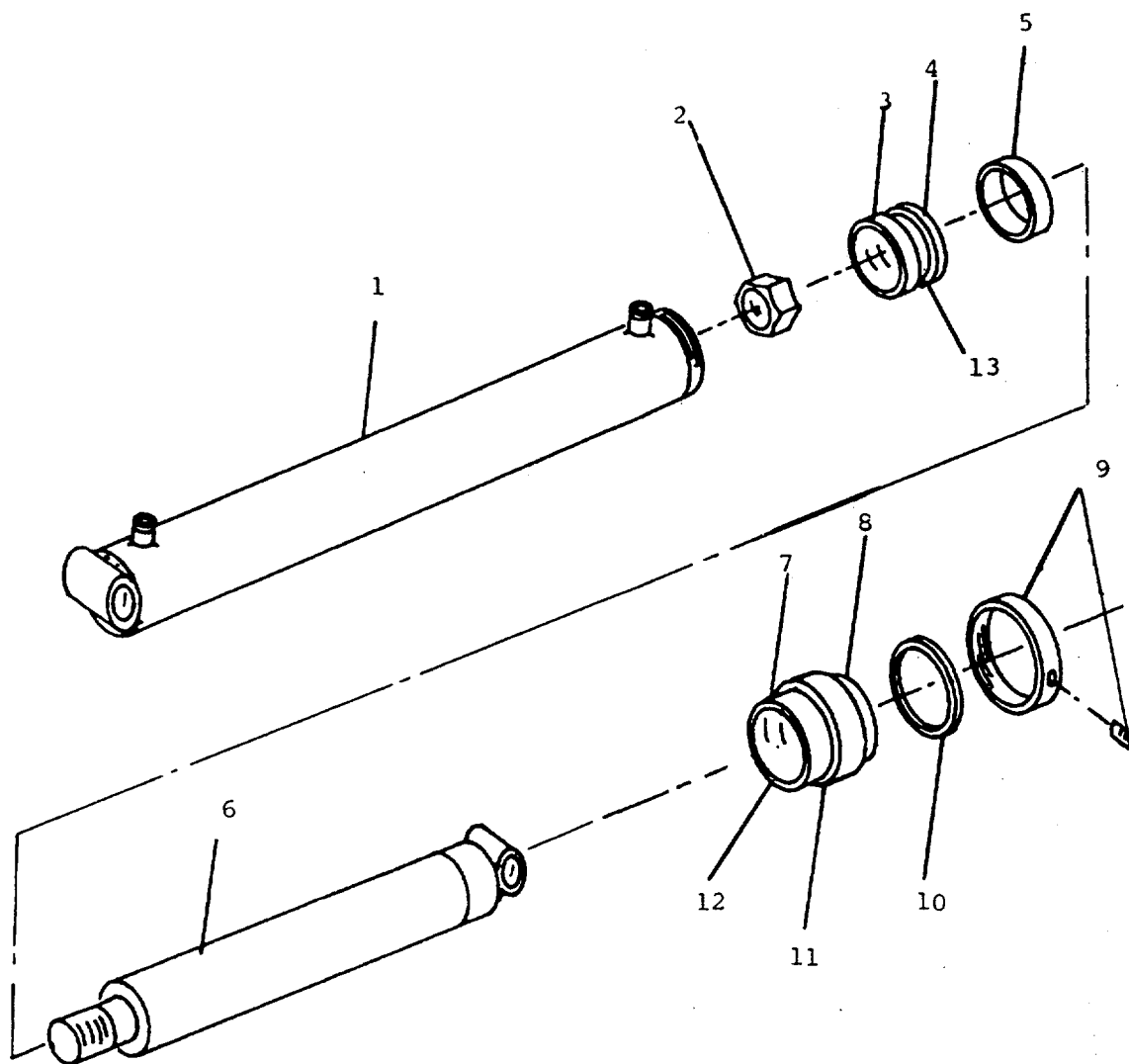

Figure 5-30. Lift Cylinder Assembly

REPLACEMENT**NOTE**

Cover ends of hoses and cylinder ports immediately upon disconnecting hoses.

1. Separate outer cylinder (1) by pulling piston rod (6) away.
2. Remove nut (2) from piston rod (6).
3. Remove piston (3) and U-cups (4). Remove O-ring (13).
4. Remove spacer (5) by sliding off piston rod (6).
5. Slide head assembly (8) down and off piston rod (6).
6. Remove O-ring (10) and back-up ring (11).
7. Remove poly pak (12) and rod wiper (7).
8. Install poly pak (12) and rod wiper (7).
9. Install O-ring (10).
10. Install back-up ring (11).
11. Slide head assembly onto rod (6).
12. Slide spacer (5) onto rod.
13. Install O-ring (13).
14. Install U-cups (4).
15. Install piston (3).

Section III. PREPARATION FOR SHIPMENT OR STORAGE

5-33. Refer to paragraph 4-68, Section VI.

CHAPTER 6

GENERAL SUPPORT MINTENANCE

	<u>Page</u>
Section I Repair Parts, Special Tools, TMDE and Support Equipment	6-1
Section II General Support Maintenance Procedures	6-2
Section III Preparation for Shipment or Storage	6-43

**Section I. REPAIR PARTS, SPECIAL TOOLS, TMDE,
AND SUPPORT EQUIPMENT**

- 6-1. COMMON TOOLS AND EQUIPMENT .** For authorized common tools and equipment, -refer to the Maintenance Allocation Chart.
- 6-2. SPECIAL TOOLS, TMDE, AND SUPPORT EQUIPMENT .** Refer to the Repair Parts and Special Tools List (TM 5-2010-205-24P) and to the Maintenance Allocation Chart (Appendix B) for the special tools, TMDE, and support equipment required.
- 6-3. REPAIR PARTS.** Repair parts are listed and illustrated in the Repair Parts and Special Tools List (TM 5-2010-205-24P) covering General Support Maintenance for this equipment.

Section II. MAINTENANCE OF ENGINE AND PROPELLING UNIT.

6-4. REPAIR PROPELLING UNIT

This Task Covers: a. Repair b. Overhaul

INITIAL SETUP

Tools Required

None

Equipment Conditions

Engine Shutdown (para 2-11).
Battery Disconnected (para 4-58).

Materials/Parts Required

None

Personnel Required

3 Persons

REPAIR

NOTE

6-5. REPAIR ENGINE ASSEMBLY

This Task Covers: a. Repair

INITIAL SETUPTools Required

None

Equipment Conditions

Engine Shutdown (para 2-11).
Battery Disconnected (para 4-58).
Doors and Top Cover Removed
(para. 5-5).
Engine Removed (para. 5-6).

Materials/Parts Required

None

Personnel Required

3 Persons

REPAIR

1. Repair Auxiliary Lines (paragraph 4-27).
2. Repair Connection Assembly (paragraph 4-26).
3. Repair Cooler Assembly (Oil) (paragraph 4-13).
4. Repair Cylinder Head Assembly (paragraph 5-20).
5. Repair Expansion Tank Assembly (paragraph 4-17).
6. Repair Front Housing Assembly (paragraph 6-7).
7. Repair Governor Drive Assembly (paragraph 6-8).
8. Repair Manifold Assembly (paragraph 5-10).
9. Repair Oil Filter Assembly (paragraph 4-32).
10. Repair Oil Pan Assembly (paragraph 5-12).
11. Repair Oil Pump Assembly (paragraph 5-8).
12. Repair PCV Lines Assembly (paragraph 4-33).
13. Repair Piston and Rod Assembly (paragraph 6-13).
14. Repair Seawater Cooling Assembly (paragraph 4-57).
15. Repair Starter Motor Assembly (paragraph 5-24).
16. Repair Turbocharger Assembly (paragraph 5-9, 6-6).
17. Repair Turbocharger Lines Assembly (paragraph 4-35, 5-9).
18. Repair Valve Mechanism Assembly (paragraph 5-21).
19. Repair Water Pump Assembly (paragraph 4-41).

6-6. REPAIR TURBOCHARGER ASSEMBLY

This Task Covers: a. Repair

INITIAL SETUP

Tools Required

Tool Kit, General Mechanics
(Appendix B, Item 1)
Turbo Fixture Group
(Appendix B, Item 8)
Fixture Assembly
(Appendix B, Item 15)

Equipment Conditions

Engine Shutdown (para 2-11).
Battery Disconnected (para 4-58).
Air Intake Filter Removed
(para 4-49).
Turbo Lines Removed (para 4-35).
Air Lines Removed (para 4-31).
Turbocharger Assembly Removed
(para 5-9).

Materials/Parts Required

Cotton Rags (Appendix E,
Item 3)
Gasket P/N 7M7273
Cartridge P/N 4N6701
Turbocharger Assembly
P/N 6N0580
Seal P/N 4L8337
Gasket P/N 7W9706
Gasket P/N 1S4810
Gasket P/N 1S6595
Seal P/N 5P7530
Seal P/N 5P9890
Seal P/N 8M5127
Filter Element
P/N 7W5040

Personnel Required

2 Persons

REPAIR (Figure 6-1.)

1. Loosen and remove nuts and washers (2).
2. Remove turbocharger assembly (1).
3. Remove gasket (3).
4. Install turbocharger assembly in holding device.

NOTE

Put marks on the three housings (7, 5, and 1) prior to disassembly to insure proper alignment at reassembly.

5. Loosen "V" clamp (4) and (6).
6. Remove cartridge housing (5) from turbine housing (1).

NOTE

Make sure all oil passages in turbocharger housing are clean and free of dirt and foreign material.

NOTE

Make sure the marks on the housings are in alignment with each other.

NOTE

Put anti-seize compound on threads of "V" clamp before installation.

7. Install "V" clamp (4) and tighten to 120 lb-in.
8. Install compressor housing (1) onto the cartridge assembly (5).
9. Install "V" clamp (6) and tighten to 120 lb-in.
10. Install gasket (3).
11. Install turbocharger assembly.
12. Install and tighten nuts and washers (2).

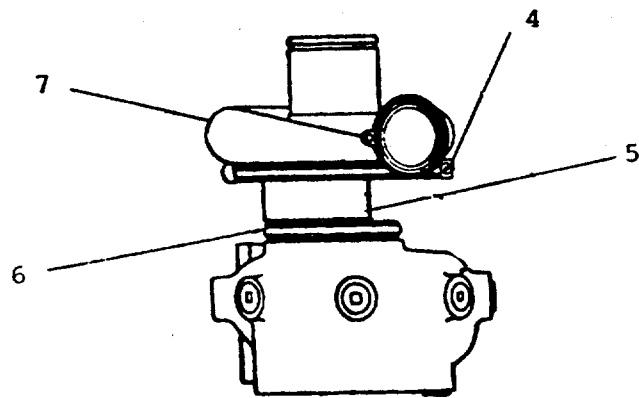
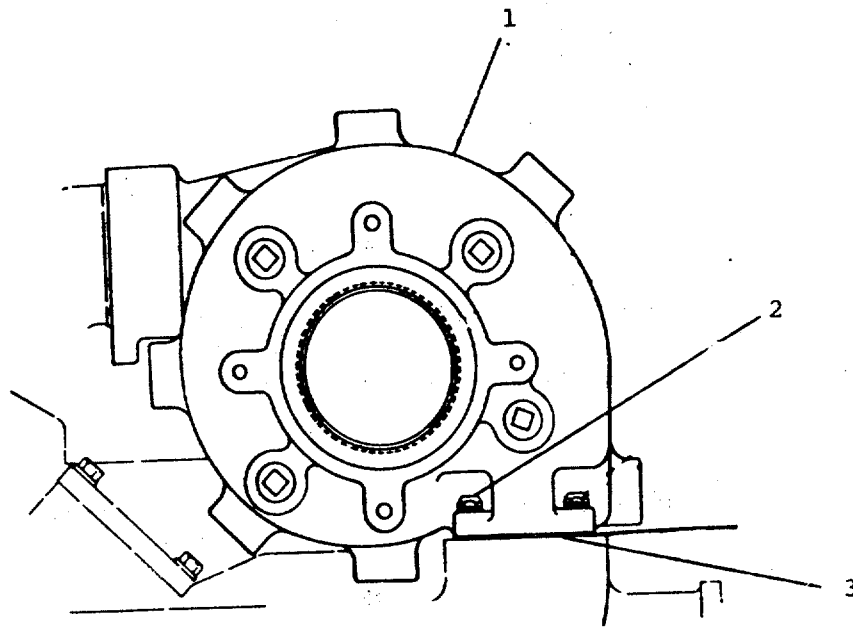

Figure 6-1. Turbocharger Assembly

6-7. REPAIR/REPLACE FRONT HOUSING ASSEMBLY

This Task Covers: a. Repair b. Replacement

INITIAL SETUPTools Required

Tool Kit, General Mechanics
(Appendix B, Item 1)
Shop Equipment (Appendix B,
Item 2)
Shop Equipment (Appendix B,
Item 4)
Puller Assembly (Appendix B,
Item 11)
Puller (Appendix B, Item 13)

Materials/Parts Required

Cotton Rags (Appendix E,
Item 3)
Sealing Compound
(Appendix E, Item 6)
Lubricating Oil
(Appendix E, Item 2)
Front Seal P/N 7C6660
Gasket P/N 9N0258

Equipment Conditions

Engine Shutdown (para. 2-11).
Hydraulic Pump Removed
(para 5-25).
Exhaust System Removed
(para 4-50).
Battery Disconnected (para 4-58).
Engine Removed (para 5-6).
Guard Removed (para 4-48).
Alternator Removed (para 4-46).
Fuel Prime Pump Removed
(para 4-18).
Fuel Filter Removed
(para 4-23).
Damper and Pulley Removed
(para 4-43).
Water Pump Removed
(para 4-41).
Expansion Tank Removed
(para 4-17).
Governor Removed (para 5-16).
Oil Pan Removed (para 5-12).
Oil Pump Removed (para 5-8).

Personnel Required

2 Persons

REPAIR Repair is limited to the replacement of defective parts.

REPLACEMENT (Figure 6-2.)

1. Remove bolt (3) and washer (2) from crankshaft (1).
2. Remove pulley assembly (4).
3. Remove crankshaft front seal (5).
4. Remove bolts (10).
5. Remove water lines (6) and (9).

6. Remove tachometer drive adapter (7).
7. Remove elbows (8) and (12).
8. Remove clamps from water sleeves (13).
9. Push sleeves (13) into timing gear cover.

NOTE

Put identification on bolts as to their location for use at installation.

10. Remove bolts (14) that hold timing gear cover.

CAUTION

Use care not to damage crankshaft from seal during timing gear cover removal.

11. Remove timing gear cover (15).
12. Remove gasket (16).

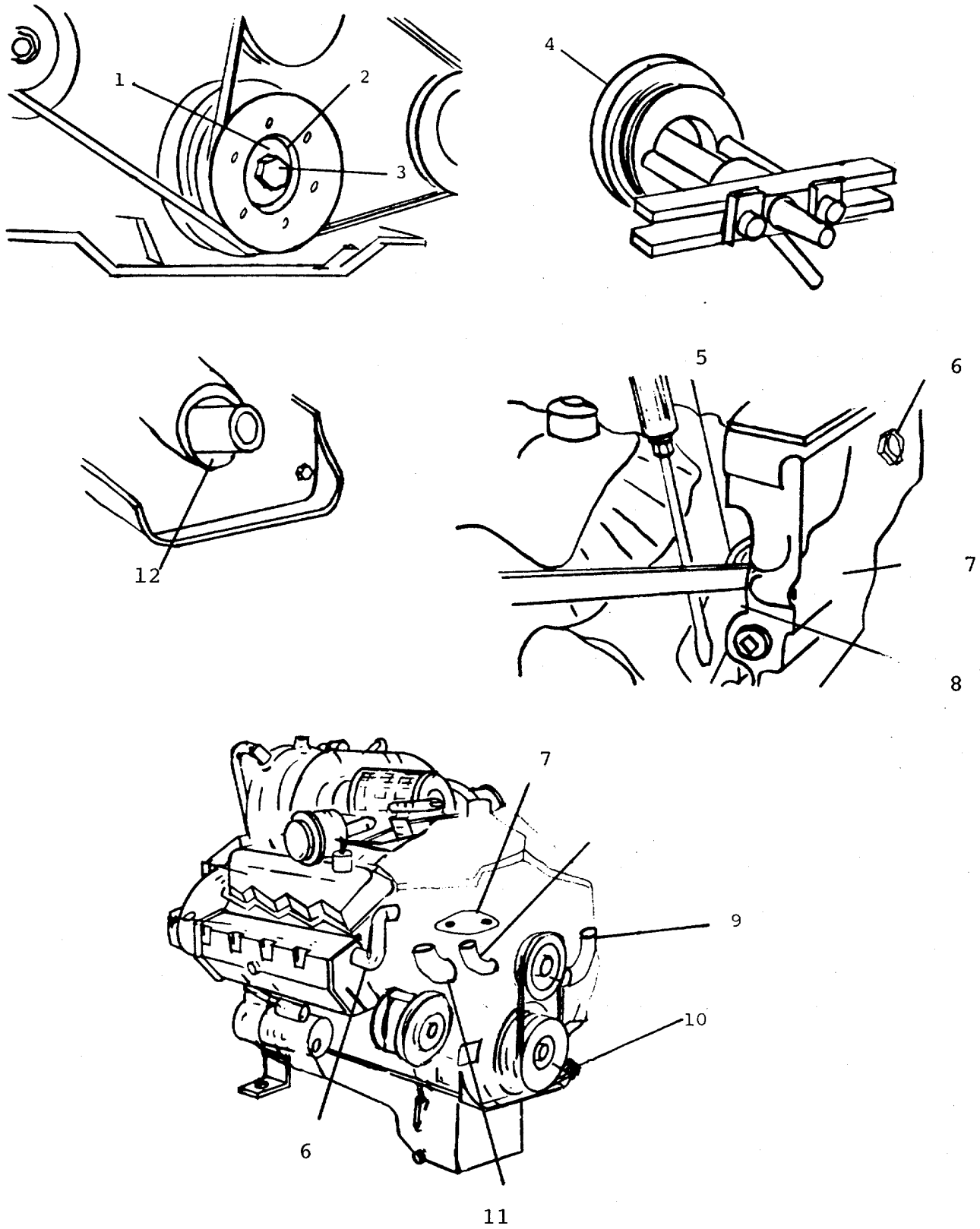

Figure 6-2. Front Housing Assembly

13. Install gasket (16).
14. Install timing gear cover (7).
15. Install bolts (14).
16. Push water sleeves (5) into cylinder head.
17. Install elbows (8) and (11).
18. Install elbows (6) and (9).
19. Install tachometer drive adapter (7).
20. Install water lines (6) and (9).
21. Install bolts (10).
22. Put sealing compound on outer metal surfaces of crankshaft front seal.

NOTE

Lip of seal must be toward inside of engine.

23. Put seal (5) in position on end of crankshaft with installer.
24. Install washer (2) and bolt (3).
25. Tighten bolt until installer makes contact with crankshaft gear.
26. Put lubricating oil on lip of seal and sealing surfaces of crankshaft pulley.
27. Install pulley on end of crankshaft.
28. Use installer to seal pulley against crankshaft gear.
29. Remove installer.
30. Install washer (2) and bolt (3).
31. Tighten bolt (3) to 400 lb.-ft.

6-8. REPAIR/REPLACE GOVERNOR DRIVE ASSEMBLY

This Task Covers: a. Inspect b. Repair c. Replacement

INITIAL SETUP
Tools Required

Tool Kit, General Mechanics
 (Appendix B, Item 1)
 Tool Kit, Automotive
 (Appendix B, Item 3)
 Shop Equipment (Appendix B,
 Item 2)
 Shop Equipment (Appendix B,
 Item 4)
 Puller Assembly (Appendix B,
 Item 11)
 Puller (Appendix B, Item 13)
 Dial Indicator (Appendix B,
 Item 10)
 Valve Seat Puller (Appendix B,
 Item 17)
 Spring Compressor (Appendix B,
 Item 16)
 Installer (Appendix B, Item 18)
 Locater (Appendix B, Item 23)
 Bolt (Appendix B, Item 24)
 Nut (Appendix B, Item 25)
 Timing Pin (Appendix B,
 Item 6)
 Puller Plate (Appendix B,
 Item 5)
 Puller (Appendix B, Item 19)
 Spacer (Appendix B, Item 20)
 Spacer (Appendix B, Item 21)
 Bearing Tool (Appendix B,
 Item 26)
 Bearing Puller (Appendix B,
 Item 12)
 Bolts (Appendix B, Item 22)
 Fixture Group (Appendix B,
 Item 8)
 Fixture Assembly (Appendix B,
 Item 15)
 Puller Assembly (Appendix B,
 Item 9)

Equipment Conditions

Engine Shutdown (para 2-11).
 Battery Disconnected (para 4-58).
 Doors and Top Cover Removed
 (para 5-5).
 Hydraulic Pump Removed
 (para 5-25).
 Exhaust System Removed
 (para 4-50).
 Engine Removed (para 5-6).
 Air Filter Removed (para 4-49).
 PCV Lines Removed (para 4-33).
 Guard Removed (para 4-48).
 Oil Filter Gauge Removed
 (para 4-20).
 Water Pump Removed (para 4-41).
 Pulley and Damper Assembly
 Removed (para 4-43).
 Alternator Removed (para 4-46).
 Fuel Prime Pump Removed
 (para 4-18).
 Fuel Filter Removed (para 4-23).
 Air Lines Removed (para 4-31).
 Turbocharger Lines Removed
 (para 4-35).
 Fuel Injection Lines Removed
 (para 4-29).
 Turbocharger Removed (para 5-9).
 Oil Pan Removed (para 5-12).
 Oil Pump Removed (para 5-8).
 Expansion Tank Removed
 (para 4-17).
 Valve Covers Removed
 (para 4-30).
 Manifold Assembly (para 5-10).
 Valve Lifters (para 5-21).
 Governor and Pump (para 5-16).
 Front Cover Removed (para 6-7).
 Cam Shaft Removed (para 6-10).

Materials/Parts Required

Cotton Rags (Appendix E,
Item 3)

Personnel Required

2 Persons

INSPECT (Figure 6-3).

1. Inspect gear teeth for chipping or scoring.
2. Inspect for damage.

REPAIR Repair is limited to the replacement of defective parts.

REPLACEMENT

1. Remove engine camshaft gear (4) (para 6-10).
2. Remove bolt (1) and washer (2).
3. Remove gear (3).
4. Install gear (3).
5. Install washer (2) and bolt (1).
6. Install camshaft gear (para 6-10)

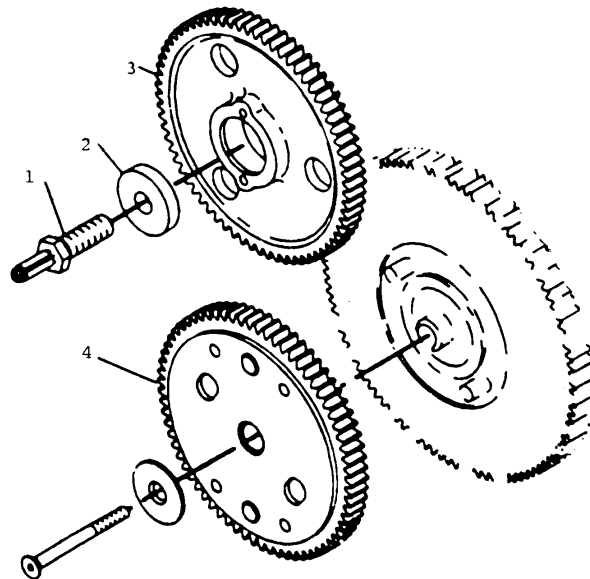

Figure 6-3. Governor Drive Assembly

6-9. REPLACE CRANKSHAFT SEAL ASSEMBLY

This Task Covers: a. Inspect b. Replacement

INITIAL SETUPTools Required

Tool Kit, General Mechanics
(Appendix B, Item 1)
Tool Kit, Automotive
(Appendix B, Item 3)
Shop Equipment (Appendix B,
Item 2)
Shop Equipment (Appendix B,
Item 4)
Puller Assembly (Appendix B,
Item 11)
Puller (Appendix B, Item 13)
Dial Indicator (Appendix B,
Item 10)
Valve Seat Puller (Appendix B,
Item 17)
Spring Compressor (Appendix B,
Item 16)
Installer (Appendix B, Item 18)
Locater (Appendix B, Item 23)
Bolt (Appendix B, Item 24)
Nut (Appendix B, Item 25)
Timing Pin (Appendix B,
Item 6)
Puller Plate (Appendix B,
Item 5)
Puller (Appendix B, Item 19)
Spacer (Appendix B, Item 20)
Bearing Tool (Appendix B,
Item 26)
Bearing Puller (Appendix B,
Item 12)
Bolts (Appendix B, Item 22)
Fixture Group (Appendix B,
Item 8)
Fixture Assembly (Appendix B,
Item 15)
Puller Assembly (Appendix B,
Item 9)

Equipment Conditions

Engine Shutdown (para 2-11).
Battery Disconnected (para 4-58).
Doors and Top Cover Removed
(para 5-5).
Exhaust System Removed
(para 4-50).
Hydraulic Pump Removed
(para 5-25).
Engine Removed (para 5-6).
Guard Removed (para 4-48).
Air Lines Removed (para 4-31).
Turbo Lines Removed (para 4-35).
Fuel Injection Lines Removed
(para 4-29).
Starter Removed (para 4-44).
Air Filter Removed (para 4-49).
Oil Level Gauge Removed
(para 4-20).
Oil Pan Removed (para 5-12).
Oil Pump Removed (para 5-8).
Expansion Tank Removed
(para 4-17).
Fuel Prime Pump (para 4-18).
Fuel Filter Removed (para 4-23).
Damper and Pulley (para 4-43).
Water Pump Removed (para 4-4-1).
Alternator Removed (para 4-46).
Turbocharger Removed (para 5-9).
Manifold Assembly Removed
(para 5-10).
Governor Removed (para 5-16).
Flywheel Removed (para 5-17).
Front Seal Removed (para 6-7).

Materials/Parts Required

Front Seal P/N 7C6660
Rear Seal P/N 7W3200

Personnel Required

2 Persons

INSPECT

1. Inspect front seal for cuts or damage.
2. Inspect rear seal for cuts or damage.

REPLACEMENT

1. Remove crankshaft rear seal (1) with puller assembly.

CAUTION

If crankshaft seal and wear sleeve come apart during installation, they must be discarded and replaced with a new seal and sleeve assembly.

2. Clean crankshaft outside diameter and put sealing compound on surface.
3. Install locater (3) and bolts on rear of crankshaft.
4. Put wear sleeve and seal assembly (1) on locater with outside diameter bevel of wear sleeve toward outside.
5. Put installer (5) in position on locater.
6. Put lubricating oil on face of nut (4).
7. Install nut on locater.
8. Tighten nut until installer is at bottom.
9. After removing installation tools, check seal for correct position.

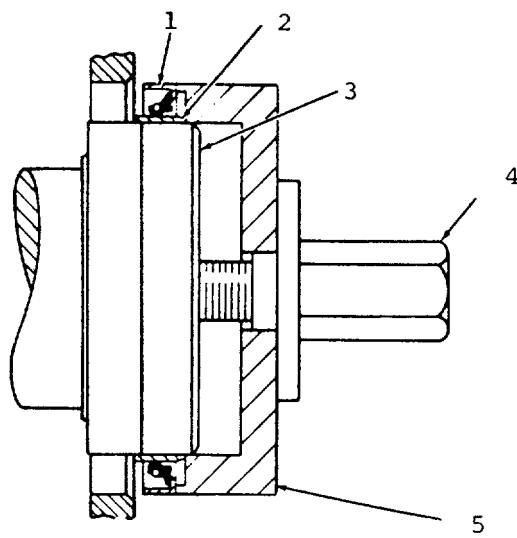

Figure 6-4. Crankshaft Seal Assembly

6-10. REPLACE CAMSHAFT ASSEMBLY

This Task Covers: a. Inspect b. Replacement

INITIAL SETUP

Tools Required

Tool Kit, General Mechanics
(Appendix B, Item 1)
Tool Kit, Automotive
(Appendix B, Item 3)
Shop Equipment (Appendix B,
Item 2)
Shop Equipment (Appendix B,
Item 4)
Puller Assembly (Appendix B,
Item 11)
Puller (Appendix B, Item 13)
Dial Indicator (Appendix B,
Item 10)
Valve Seat Puller (Appendix B,
Item 17)
Spring Compressor (Appendix B,
Item 16)
Installer (Appendix B, Item 18)
Locator (Appendix B, Item 23)
Bolt (Appendix B, Item 24)
Nut (Appendix B, Item 25)
Timing Pin (Appendix B,
Item 6)
Puller Plate (Appendix B,
Item 5)
Puller (Appendix B, Item 19)
Spacer (Appendix B, Item 20)
Spacer (Appendix B, Item 21)
Bearing Tool (Appendix B,
Item 26)
Bearing Puller (Appendix B,
Item 12)
Bolts (Appendix B, Item 22)
Fixture Group (Appendix B,
Item 8)
Fixture Assembly (Appendix B,
Item 15)
Puller Assembly (Appendix B,
Item 9)

Equipment Conditions

Engine Shutdown (para 2-11).
Battery Disconnected (para 4-58).
Doors and Top Cover Removed
(para 5-5).
Exhaust System Removed
(para 4-50).
Hydraulic Pump Removed
(para 5-25).
Guard Removed (para 4-48).
Engine Removed (para 5-6).
Air Lines Removed (para 4-31).
Turbo Lines Removed (para 4-35).
Fuel Injection Lines Removed
(para 4-29).
Starter Removed (para 4-44).
Air Filter Removed (para 4-49).
Oil Level Gauge Removed
(para 4-20).
Oil Pan Removed (para 5-12).
Oil Pump Removed (para 5-8).
Expansion Tank Removed
(para 4-17).
Fuel Prime Pump Removed
(para 4-18).
Fuel Filter Removed (para 4-23).
Damper and Pulley Removed
(para 4-43).
Water Pump Removed (para 4-41).
Alternator Removed (para 4-46).
Turbocharger Removed (para 5-9).
Manifold Assembly Removed
(para 5-10).
Governor Removed (para 5-16).
Flywheel Removed (para 5-17).
Front Seal Removed (para 6-7).
Valve Lifters Removed
(para 5-21).
Front Cover Removed (para 6-7).

Materials/Parts Required

Personnel Required

Cotton Rags (Appendix E, Item 3)
 Lubrication Oil (Appendix E, Item 2)
 Permanent Antifreeze (Appendix E, Item 4)
 Cleaning Solution (Appendix E, Item 1)
 Gasket Sealant (Appendix E, Item 6)
 Screw P/N P07154
 Screw P/N M590728-62
 Plug P/N P10137
 Screw P/N MS90728-111
 Washer P/N MS51412-10
 Nut P/N MS25082-19
 Bolt P/N MS90728-32
 Washer P/N MS51412-5
 Bumper Strip P/N 3MD-1
 Tube P/N B100386
 Valve P/N P16008
 Hose P/N E7HU0608MB06NJ-40
 Elbow P/N 849-FS-06X04
 Hose P/N E7HU0606MB06NJ-45
 Screw P/N MS90728-189
 Washer P/N P07013
 Screw P/N MS90728-170
 Nut P/N MS25082-10
 Washer P/N P07020
 Mount P/N CBA24-650
 Gasket P/N P05032
 Cap P/N UC-PAB-1730-40-5
 Gauge P/N P17000
 Bolt P/N P07155
 Washer P/N MS51416-2
 Screw P/N MS90728-58
 Washer P/N MS35338-46
 Screw P/N MS90728-60
 Pump Drive P/N DPO1-2-11-E4
 Screw P/N MS90728-189
 Washer P/N P07013
 Pumping Unit
 P/N P11P-1R14-4A2-A-M2-04280
 Valve P/N S23-11425-ND
 Screw P/N 306-40189
 Cover P/N S13-42064-C
 Valve P/N S23-1513-C
 Screw P/N 359-15220
 Packing P/N 691-00916
 Pump P/N TKP4-26-14.3DSC06
 Gasket P/N P05001
 Gasket P/N 48-40

2 Persons

Muffler P/N DCU-04-0410
Adapter P/N 64-40
Adapter P/N C100454
Elbow P/N C100453
Elbow P/N 56-40
Gasket P/N P05001
Gasket P/N 48-40
Muffler P/N DCU-04-0410
Adapter P/N c100454
Elbow P/N C100453
Elbow P/N 56-40
Bolt P/N OS1587
Bolt P/N 051619
Bolt P/N OT0319
Nut P/N 1D4717
Nut P/N 1D4719
Washer P/N 1F7346
Washer P/N 2M0849
Tank Assembly P/N 2W0890
Cap P/N 068865
Elbow P/N 6B9807
Bolt P/N 4F8965
Washer P/N 5M2894
Grommet P/N 6N6984
Bolt P/N 8S9191
Washer P/N 9M1974
Gasket P/N 1P0436
Oil Level Gage P/N 4N4542
Filter Element P/N 1P2299
Gasket P/N 1P0436
Seal P/N 4L8337
Gasket P/N 7W9706
Gasket P/N 1S4810
Gasket P/N 1S6595
Seal P/N 5P7530
Seal P/N 5P9890
Seal P/N 8M5127
Gasket P/N 9N0137
Seal P/N 2W0712
Water Pump Assembly
P/N 9N6147
Guard Assembly P/N 2W9559
Filter Element P/N 7W5040
Engine P/N PA0520
Gasket P/N 7M7273
Cartridge P/N 4N6701
Turbocharger Assembly
P/N 6N0580
Gasket P/N 7W1641
Gasket P/N 7W1642
Gasket P/N 9L8027
Manifold Assembly
P/N 2W8470
Pan P/N 4N4475

MATERIALS/PARTS REQUIRED

Packing P/N 3K0360
Plug PIN 9S4185
Gasket P/N 918O16
Bolt P/N 9L9178
Oil Level Gauge
P/N 4N4542
Governor Pimp Assembly
PIN 7C9496
Flywheel Assembly
P/N 7W1534
Front Seal PFN 7C6660
Gasket PFN 9N0258
Oil Pump Assembly
P/N 1N4254
Bolt P/N 051618
Bolt PIN ID4539
Plunger P/N 1N3165
Spring P/N IW1788
Guide P/N 7W0239
Seal P/N 8L2746
Gear PIN 9N5569
Bearing P/N 9N5572
Pan P/N 4N4475
Packing P/N 3K0360
Plug PIN 9S4185
Gasket P/N 9L8016
Bolt P/N 9L9178
Valve Mechanical Assembly
P/N 9N3603
Bolt P/N MS90728-43
Tappet PRN 9La6931
Bolt P/N MS90728-40
Rocker Arm P/N 2W8271
Washer P/N 2W6047
Screw P/N 5S5917
Nut P/N 9L7712
Washer P/N 9L8076
Shaft P/N 9L9315
Washer P/N 9M1974
Holder P/N 9N0141
Push Rod P/N 9N6500
Gasket PIN 4F9325
Camshaft PIN 9N3597
Pin P/N 5P4283
Gear PIN 9N5378
Pin P/N 9N5771
Pin P/N 9N6218

INSPECT (Figure 6-5).

1. Inspect camshaft lobes for pits or scuffing.
2. Inspect gears for damage.

NOTE

Camshaft bearing journals have a diameter of 2.4995 inch to 2.5005 inch and the minimum diameter worn is 2.4970 inch.

3. Inspect camshaft bearing journals.
4. Inspect camshaft lobe height by:
 - a. Measure lobe height (B) of one exhaust and one intake lobe.
 - b. Measure base circle (C) of one exhaust and one intake lobe.
 - c. Subtract base circle (C) dimension (Step b.) from lobe height (B) dimension (Step a.).

NOTE

Specified new lobe lift (A) is
.370 inch for exhaust lobe and
.367 inch for intake lobe.

- d. The difference is actual lobe lift (A).

NOTE

Maximum permissible differences between actual lobe lift (A) and specified lobe lift is .010 inch.

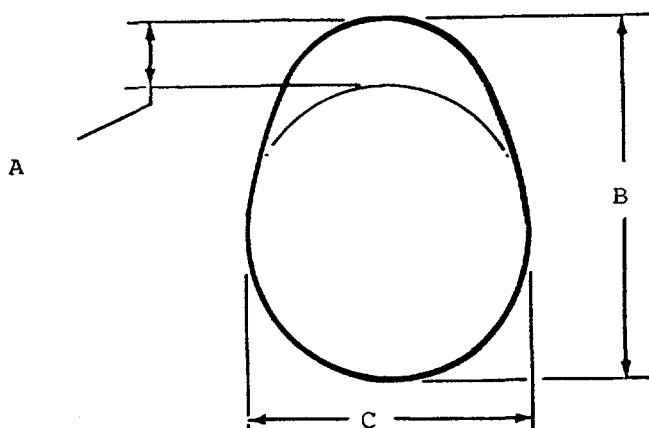

Figure 6-5. Camshaft Lobe.

REPLACEMENT (Figure 66.)

1. Remove plug (1) from fuel injection pump housing (2).
2. Install timing pin (4).
3. Crankshaft clockwise as seen from front of engine until timing pin (4) slides into the slot in the fuel injection pump camshaft.
4. Remove tachometer drive adapter (3).
5. Remove screw (5) and washer (6) from end of camshaft.
6. Remove automatic timing advance (7).
7. Remove thrust pin (8) located at rear of binder block.
8. Remove camshaft (9) and camshaft gear (10).
9. Install three leg puller on camshaft gear (10) and remove gear.

CAUTION

Do not heat gear with torch. Do not heat gear to more than 600 degrees F.

10. Heat gear to approximately 400 degrees F. in oil bath.
11. Align slot in gear hub with pin in camshaft.

CAUTION

Be sure gear is completely seated against shoulder of camshaft.

CAUTION

Do not drive gear on camshaft.

12. Install gear on camshaft with timing mark on gear aligned with timing mark on crankshaft gear.
13. Align holes in weights with dowels in gear and install automatic timing advance.
14. Align pin (9) in washer with hole (10) in camshaft.
15. Install washer (9).
16. Install screw (11) and tighten to 70 lb.-ft.

NOTE

After screw is staked, gear and weight assembly requires .003 to .037 inch end clearance.

17. Stake screw in two places.

CAUTION

Stake screw (11) carefully.

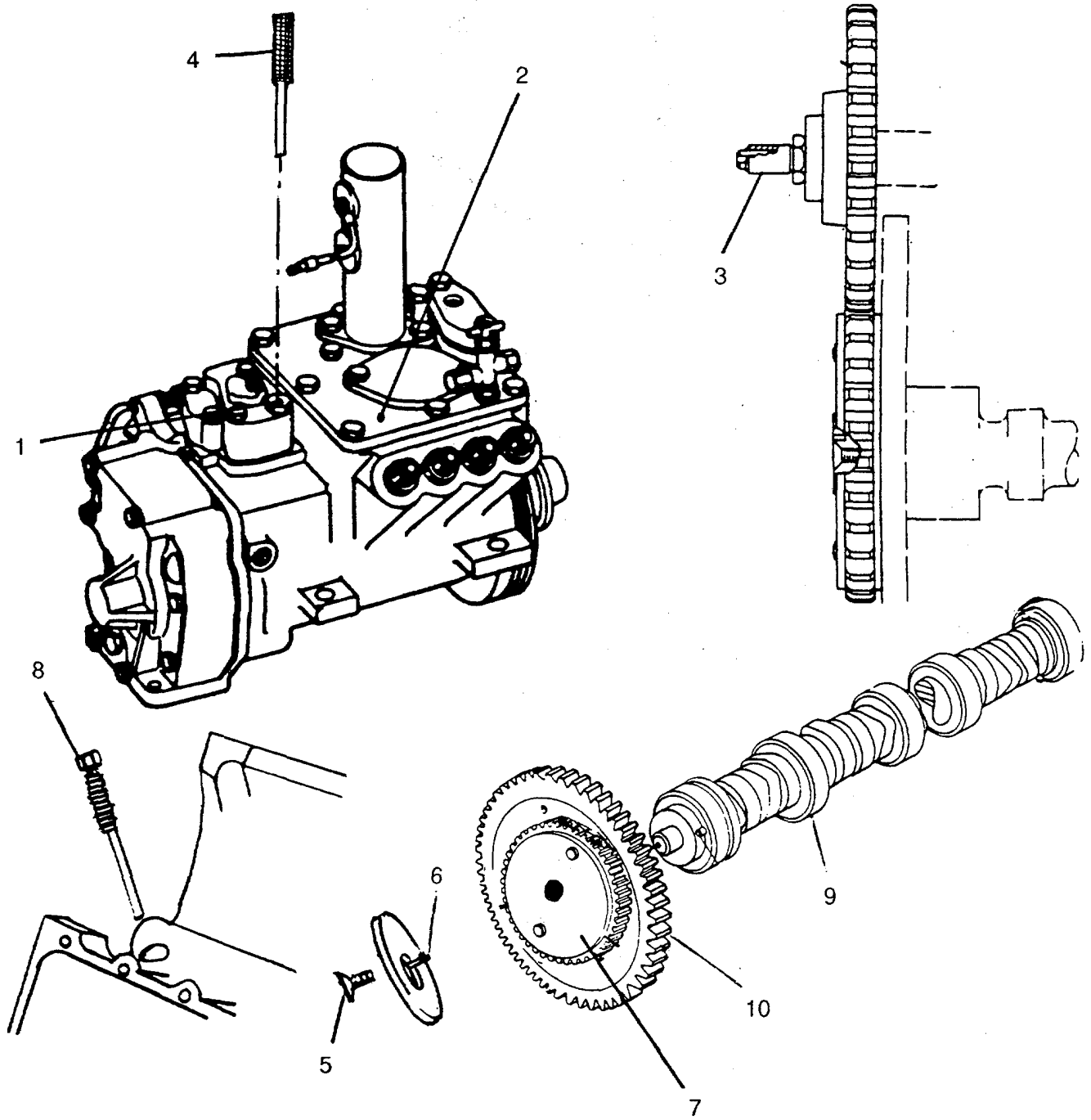

Figure 6-6. Camshaft and Gear Assembly.

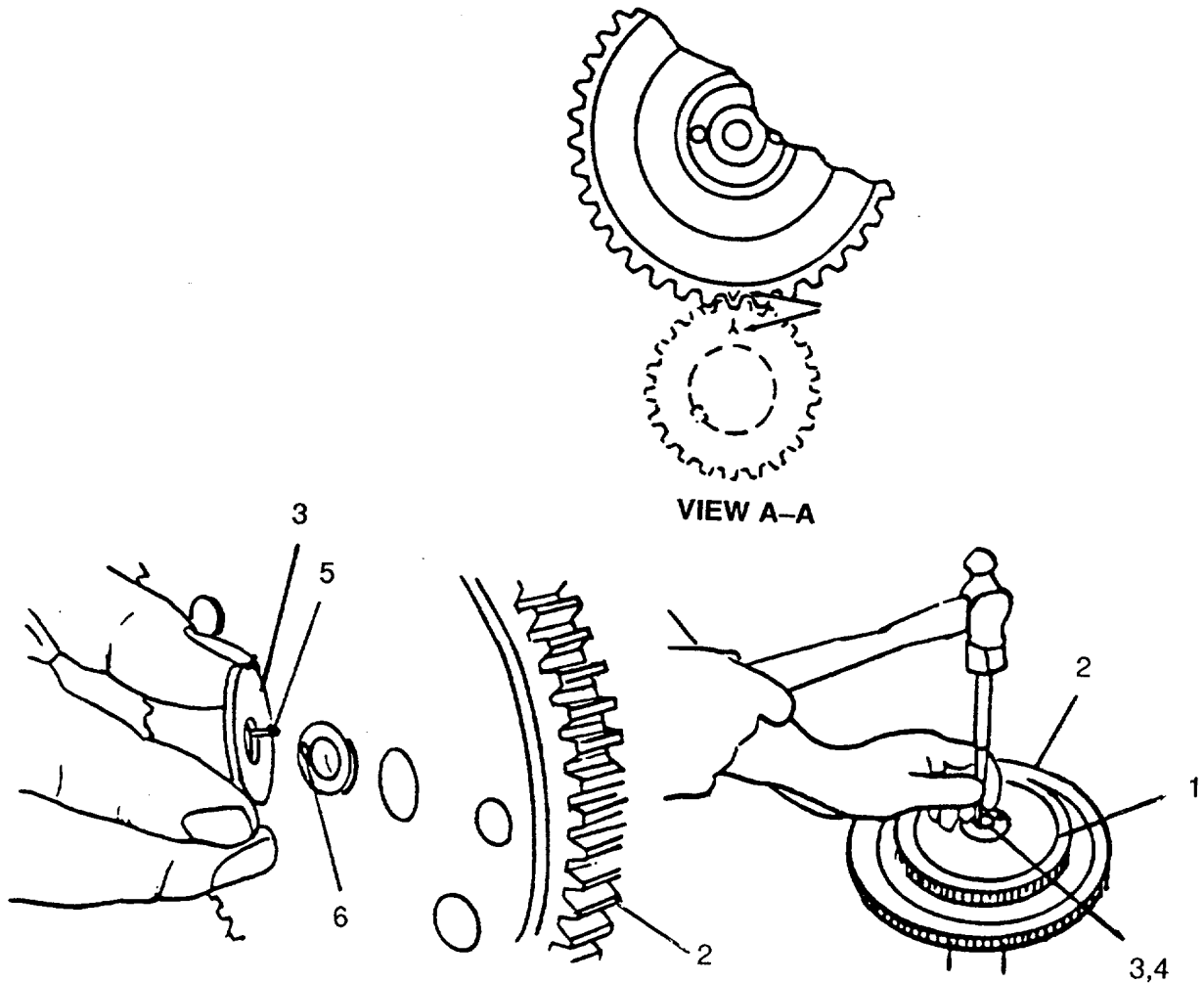

Figure 6-7. Camshaft Gears.

INSTALL CAMSHAFT GEAR AND CAMSHAFT

CAUTION

Do not heat gear with torch. Do not heat gear to more than 600°F.

1. Heat gear (2) to approximately 400°F. in oil bath.
2. Align slot in gear hub with pin in camshaft.

CAUTION

Do not drive gear on camshaft.

INSTALL CAMSHAFT GEAR AND CAMSHAFT

CAUTION

Be sure gear is completely seated against shoulder of camshaft.

3. Install automatic timing advance (1) on camshaft gear (6) aligning holes in weights with dowels in camshaft gear.
4. Install washer (3) aligning pin (5) in washer with hole (6) in camshaft.
5. Install screw (4) and tighten to 70 lb.-ft.

NOTE

After screw is staked, gear and weight assembly requires .001 to .037 inch end clearance.

6. Stake screw in two places.

CAUTION

Stake screw (4) carefully.

7. Put lubricating oil on camshaft lobes and journals.
8. Install camshaft and gears as a unit.

NOTE

Make sure timing marks on crankshaft gear and camshaft gear are in alignment. (view AA)

9. Install thrust pin and tighten to 35 lb.-ft. (Fig. 6-6.)
10. Install tachometer drive adapter and tighten to 110 ft.-lb. (Fig. 6-6.)

6-11. REPLACE CRANKSHAFT ASSEMBLY

This Task Covers: a. Inspect b. Replacement

INITIAL SETUP

Tools Required

Tool Kit, General Mechanics
(Appendix B, Item 1)
Tool Kit, Automotive
(Appendix B, Item 3)
Shop Equipment (Appendix B,
Item 2)
Shop Equipment (Appendix B,
Item 4)
Puller Assembly (Appendix B,
Item 11)
Puller (Appendix B, Item 13)
Dial Indicator (Appendix B,
Item 10)
Valve Seat Puller (Appendix B,
Item 17)
Spring Compressor (Appendix B,
Item 16)
Installer (Appendix B, Item 18)
Locater (Appendix B, Item 23)
Bolt (Appendix B, Item 24)
Nut (Appendix B, Item 25)
Timing Pin (Appendix B,
Item 6)
Puller Plate (Appendix B,
Item 5)
Puller (Appendix B, Item 19)
Spacer (Appendix B, Item 20)
Spacer (Appendix B, Item 21)
Bearing Tool (Appendix B,
Item 26)
Bearing Puller (Appendix B,
Item 12)
Bolts (Appendix B, Item 22)
Fixture Group (Appendix B,
Item 8)
Fixture Assembly (Appendix B,
Item 15)
Puller Assembly (Appendix B,
Item 9)

Equipment Conditions

Engine Shutdown (para 2-11).
Battery Disconnected (para 4-58).
Doors and Top Cover Removed
(para 5-5).
Exhaust System Removed
(para 4-50).
Hydraulic Pump Removed
(para 5-25).
Guard Removed (para 4-48).
Engine Removed (para 5-6).
Air Lines Removed (para 4-31).
Turbo Lines Removed
(para 4-35).
Fuel Injection Lines Removed
(para 4-29).
Starter Removed (para 4-44).
Air Filter Removed (para 4-49).
Oil Level Gauge Removed
(para 4-20).
Oil Pan Removed (para 5-12).
Oil Pump Removed (para 5-8).
Expansion Tank Removed
(para 4-17).
Fuel Prime Pump Removed
(para 4-18).
Fuel Filter Removed (para 4-23).
Damper and Pulley Removed
(para 4-43).
Water Pump Removed (para 4-41).
Alternator Removed (para 4-46).
Turbocharger Removed (para 5-9).
Manifold Assembly Removed
(para 5-10).
Governor Removed (para 5-16).
Flywheel Removed (para 5-17).
Front Seal Removed (para 6-7).
Valve Lifters Removed
(para 5-21).
Front Cover Removed (para 6-7).
Flywheel Housing Removed
(para 5-14).
Pistons Removed (para 6-12).

Materials/Parts Required

Cotton Rags (Appendix B,
Item 3)
Lubricating Oil (Appendix B,
Item 2)

Personnel Required

2 Persons

INSPECT**NOTE**

The diameter of the journals for the connecting rod bearings is 2.7490 to 2.7502 inch.

1. Inspect diameter of journals for connecting rod bearings.

NOTE

The diameter of the journals for the main bearings is 3.4989 to 3.5001 inch.

2. Inspect diameter of journals for main bearings.

NOTE

Minimum permissible diameter for journals for connecting rod is 2.7486 inch.

NOTE

Minimum permissible diameter for journals for main bearings is 3.4985 inch.

NOTE

The maximum total indicator reading is .005 inch for each journal. If the total is more than .005 inch, the crankshaft must be replaced.

3. Inspect the total indicator reading runout for main bearing journals.

REPLACEMENT

1. Turn crankshaft until timing mark on crankshaft gear is in alignment with timing mark on camshaft gear.

NOTE

Check each main bearing cap for its location on engine. Each cap has a number. Note that the number is toward the front of the cylinder block.

2. Remove bolts (4) and washers that hold main bearing cap (5) in place.
3. Remove bearing cap and lower half of main bearing.
4. Remove crankshaft (6).
5. Remove bolts (8) and (9).
6. Remove bearing (1) from bearing cap.

CAUTION

If the crankshaft is turned the wrong direction, the tab of the bearing will be pushed between the crankshaft and the cylinder blocks.

7. Turn crankshaft until bearing tool can be installed in oil hole in crankshaft journal.
8. Install bearing tool.
9. Turn crankshaft in direction which will push upper main bearing out tab end first.

CAUTION

When bearing caps are installed, make sure the caps are installed with the part number toward the front of the engine and the number on the bottom of cap is the same as the number on camshaft side of the engine.

NOTE

Install bearings dry when clearance checks are made. Put lubricating oil on bearings for final assembly.

10. Install lower bearing in bearing caps.
11. Install upper bearings in cylinder block.

NOTE

The upper bearings have the oil hole.

12. Install bolts (4) and washers.
13. Tighten bolt (9) to 30 lb.ft.
14. Tighten bolt (8) to 30 lb.ft.
15. Turn bolt (9) 120 degrees more.
16. Turn bolt (8) 120 degrees more.
17. Remove gear from crankshaft.
18. Install crankshaft gear key so it is even with end of crankshaft.
19. Heat crankshaft gear to a maximum of 500 degrees F.

CAUTION

Timing mark on gear must be toward pulley end of shaft.

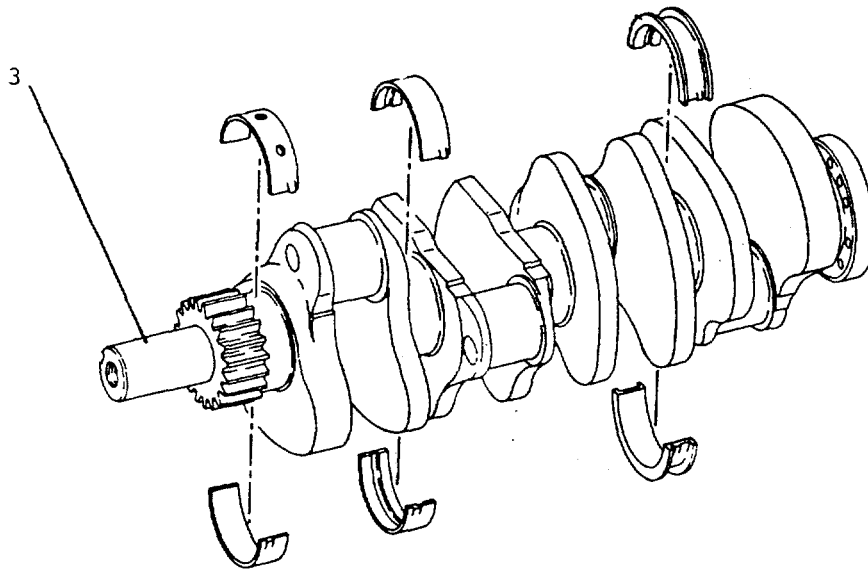

Figure 6-8. Crankshaft Main Bearings

20. Install thrust bearing for the No. 4 main.

NOTE

Make sure timing mark on the crankshaft gear is in alignment with timing gear on camshaft.

21. Put crankshaft in position in block.

CAUTION

Crankshaft end play is controlled by No. 4 main bearing. End play with new bearings is .003 to .010 inch. Maximum end play with used bearings is .014 inch.

22. Check end play of crankshaft with dial indicator.

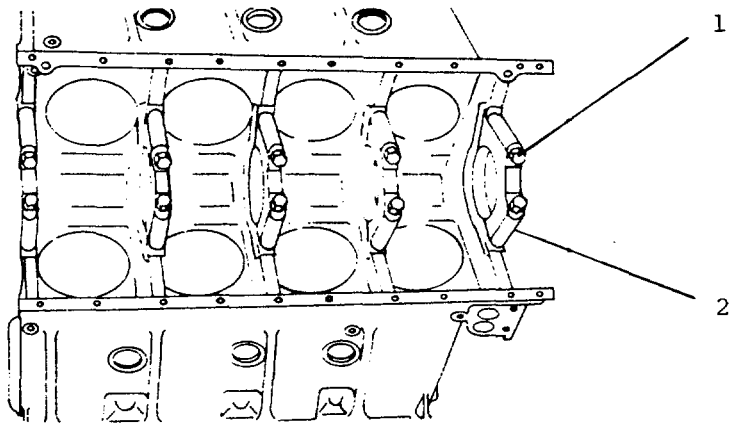

Figure 6-9. Crankshaft Assembly

6-12. REPAIR/REPLACE CYLINDER BLOCK ASSEMBLY

This Task Covers: a. Repair b. Replacement

INITIAL SETUP

Tools Required

Tool Kit, General Mechanics
(Appendix B, Item 1)
Tool Kit, Automotive
(Appendix B, Item 3)
Shop Equipment (Appendix B,
Item 2)
Shop Equipment (Appendix B,
Item 4)
Puller Assembly (Appendix B,
Item 11)
Puller (Appendix B, Item 13)
Dial Indicator (Appendix B,
Item 10)
Valve Seat Puller (Appendix B,
Item 17)
Spring Compressor (Appendix B,
Item 16)
Installer (Appendix B, Item 18)
Locater (Appendix B, Item 23)
Bolt (Appendix B, Item 24)
Nut (Appendix B, Item 25)
Timing Pin (Appendix B,
Item 6)
Puller Plate (Appendix B,
Item 5)
Puller (Appendix B, Item 19)
Spacer (Appendix B, Item 20)
Spacer (Appendix B, Item 21)
Bearing Tool (Appendix B,
Item 26)
Bearing Puller (Appendix B,
Item 12)
Bolts (Appendix B, Item 22)
Fixture Group (Appendix B,
Item 8)
Fixture Assembly (Appendix B,
Item 15)
Puller Assembly (Appendix B,
Item 9)

Equipment Conditions

Muffler and Pipe Removed
(para 4-50).
Auxiliary Lines Removed
(para 4-27).
Wiring Assembly Removed
(para 4-45).
Water Lines Removed
(para 4-25).
Air Lines Assembly Removed
(para 4-31).
Engine Removed (para 5-6).
Turbo Lines Assembly Removed
(para 4-35).
Engine Oil Lines Removed
(para 4-36).
Starter Motor Removed
(para 4-44).
Alternator Assembly Removed
(para 4-46).
Turbocharger Removed
(para 5-9)H
Air Intake Filter Removed
(para 4-49).
Oil Level Gauge Removed
(para 4-20).
Fuel Prime Pump Removed
(para 4-18).
Fuel Filter Removed
(para 4-23).
Oil Filter Assembly Removed
(para 4-32).
Cooler Assembly Removed
(para 4-13).
Guard Assembly Removed
(para 4-48).
Auxiliary Pump Removed
(para 4-47).
Expansion Tank Removed
(para 4-17).
Seawater Expansion Removed
(para 4-24).
Fuel Injection Lines Removed
(para 4-29).

Equipment Conditions (continued)

- Connection Assembly Removed
(para 4-26).
- Water Pump Removed
(para 4-41).
- Pulley and Damper Removed
(para 4-43).
- Flywheel Assembly Removed
(para 5-17).
- Flywheel Housing Removed
(para 5-14).
- Governor Pump Removed
(para 5-16).
- Governor Control Removed
(para 5-13).
- Engine Support Removed
(para 5-22).
- Lifting Assembly Removed
(para 4-34).
- Front Housing Removed
(para 6-7).
- Mechanical Cover Removed
(para 4-30).
- Manifold Assembly Removed
(para 4-40).
- PCV Lines Assembly Removed
(para 4-23).
- Cylinder Heads Removed
(para 5-20).
- Valve Mechanism Removed
(para 5-21).
- Oil Pan Removed (para 5-12).
- Camshaft Removed (para 6-9).
- Crankshaft Seal Removed
(para 6-8).
- Crankshaft Removed (para 6-10).

Materials/Parts Required

Cotton Rags (Appendix E,
Item 3)

Personnel Required

3 Persons

REPLACEMENT Replace block by re-assembling all engine components.

6-13. REPAIR/REPLACE PISTON AND ROD ASSEMBLY

This Task Covers: a. Inspect b. Repair c. Replacement

INITIAL SETUP

Tools Required

Tool Kit, General Mechanics
(Appendix B, Item 1)
Tool Kit, Automotive
(Appendix B, Item 3)
Shop Equipment (Appendix B,
Item 2)
Shop Equipment (Appendix B,
Item 4)
Puller Assembly (Appendix B,
Item 11)
Puller (Appendix B, Item 13)
Dial Indicator (Appendix B,
Item 10)
Valve Seat Puller (Appendix B,
Item 17)
Spring Compressor (Appendix B,
Item 16)
Installer (Appendix B, Item 18)
Locater (Appendix B, Item 23)
Bolt (Appendix B, Item 24)
Nut (Appendix B, Item 25)
Timing Pin (Appendix B,
Item 6)
Puller Plate (Appendix B,
Item 5)
Puller (Appendix B, Item 19)
Spacer (Appendix B, Item 20)
Spacer (Appendix B, Item 21)
Bearing Tool (Appendix B,
Item 26)
Bearing Puller (Appendix B,
Item 12)
Bolts (Appendix B, Item 22)
Fixture Group (Appendix B,
Item 8)
Fixture Assembly (Appendix B,
Item 15)
Puller Assembly (Appendix B,
Item 9)

Equipment Conditions

Engine Shutdown (para 2-11).
Battery Disconnected (para 4-58).
Doors and Top Cover Removed
(para 5-5).
Exhaust System Removed
(para 4-50).
Air Lines Removed (para 4-31).
Engine Removed (para 5-6).
Turbo Lines Removed
(para 4-35).
Starter Removed (para 4-44).
Alternator Removed (para 4-46).
Turbocharger Removed (para 5-9).
Air Filter Removed (para 4-49).
Oil Level Gauge Removed
(para 4-20).
Fuel Prime Pump Removed
(para 4-18).
Fuel Filter Removed
(para 4-23).
Guard Removed (para 4-48).
Expansion Tank Removed
(para 4-17).
Fuel Injection Lines Removed
(para 4-29).
Water Pump Removed
(para 4-41).
Hydraulic Pump Removed
(para 5-25).
Damper and Pulley Removed
(para 4-43).
Flywheel Removed (para 5-17).
Flywheel Housing Removed
(para 5-14).
Governor Removed (para 5-16).
Manifold Assembly Removed
(para 5-10).
Front Seal Removed (para 6-7).

Ridge Reamer (Appendix B, Item 27)
 Ring Compressor (Appendix B, Item 28)
 Ring Expander (Appendix B, Item 30)
 Press Group (Appendix B, Item 31)
 Hose Assembly (Appendix B, Item 32)
 Coupler Assembly (Appendix B, Item 33)
 Coupler Assembly (Appendix B, Item 34)
 Hand Pump (Appendix B, Item 35)
 Piston Ring Groove Cleaner (Appendix B, Item 29)

Cylinder Heads Removed (para 5-20).
 Valve Lifter Removed (para 5-21).
 Oil Pan Removed (para 5-12).
 Oil Pump Removed (para 5-8).
 Front Cover Removed (para 6-7).
 Pistons Removed (para 6-12).

Materials/Parts

Personnel Required

Piston Ring P/N 2W8045
 Piston Ring P/N 9L6233

2 Persons

INSPECT (Figure 6-10).

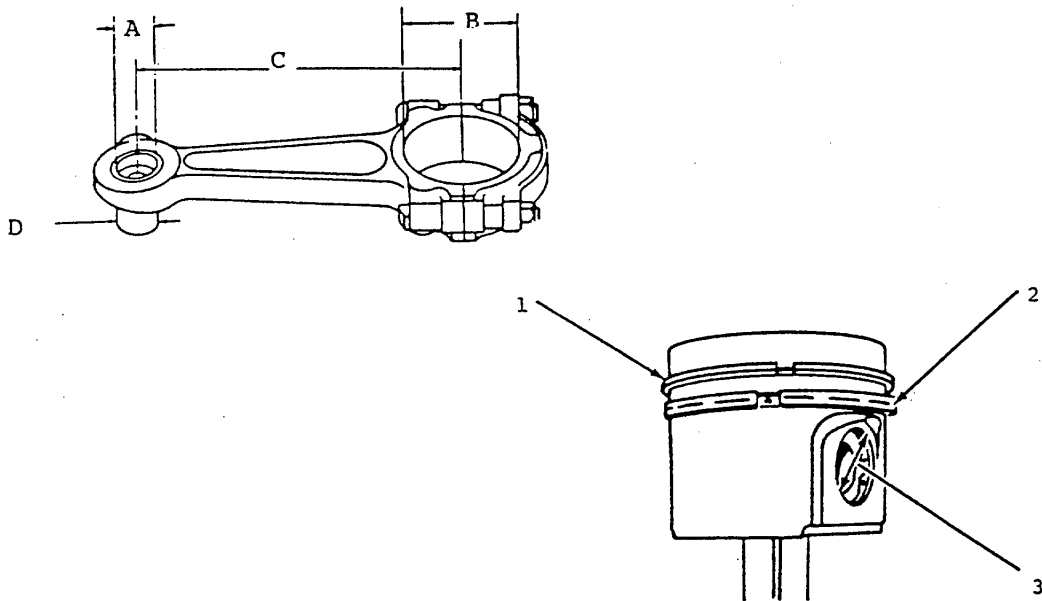

Figure 6 - 10. Piston and Rod

1. Measure bore (A) in bearing for piston pin. The minimum dimension is 1.5007 and the maximum dimension is 1.5013 inch.
2. Measure bore (B) in connecting rod for bearing. The minimum dimension is 2.9413 and the maximum dimension is 2.9423 inch.

NOTE

Nuts torque procedure: Torque nuts to 30 lb.-ft. and then turn 60 degrees more.

3. Measure distance (C) between center of bearing for piston pin and center of bearing for crankshaft journal. Minimum dimension is 7.899 and the maximum dimension is 7.901 inch.
4. Measure diameter (D) of piston pin. The minimum dimension is 1.4997 and the maximum dimension is 1.5001 inch.

NOTE

Maximum permissible clearance between bearing and piston pin is .003 inch.

5. Inspect top ring (1).
 - a. Measure width of groove in piston for piston ring. The minimum dimension is .1285 and the maximum dimension is .1295 inch.
 - b. Measure thickness of piston ring. The minimum dimension is .1240 and the maximum dimension is .1255 inch.
 - c. Measure clearance between groove and piston ring. The minimum clearance is .0030 and the maximum clearance .0055 inch.
6. Inspect oil control ring (2).
 - a. Measure width of groove in piston for piston ring. The minimum dimension is .1100 and the maximum dimension is .1110 inch.
 - b. Measure thickness of piston ring. The minimum dimension is .1080 and the maximum dimension is .1090 inch.
 - c. Measure clearance between groove and piston ring. The minimum clearance is .0010 and the maximum clearance is .0030 inch.

REPAIR Repair is limited to the replacement of defective parts.

REPLACEMENT (Figure 6-11.)

1. Remove carbon from top inside surface of the cylinders.

2. Turn crankshaft until two pistons are at bottom center.
3. Remove connecting rod caps (2) from the two connecting rods.

NOTE

Put tape or other protection on threads of connecting rod bolts.

4. Push pistons and connecting rods away from crankshaft until piston rings are above the cylinder block.
5. Remove the pistons (1) and the connecting rods.

CAUTION

Do not turn crankshaft while any connecting rods are in the engine without the caps installed.

6. Do steps 2 through 5 for the remaining pistons.
7. Remove rings from the piston.
8. Remove bearings from connecting rod and the connecting rod cap.
9. Remove snap rings (3), pin (4) and connecting rod (5) from the piston.
10. Heat connecting rod to 350-500 degrees F.
11. Put 5P8654 spacer (10) in the base plate.
12. Put connecting rod on base plate.
13. Put connecting rod piston pin bearing end in the center of the port assembly.
14. Install pin (13) in the center of the bore for the connecting rod bearings.
15. Install 5P8653 adapter (8).

NOTE

Put the hole in the adapter in alignment with the hole in base plate.

16. Install clamp bar (11) and clamp pin (12).
17. Install new piston pin bearing on adapter (8).

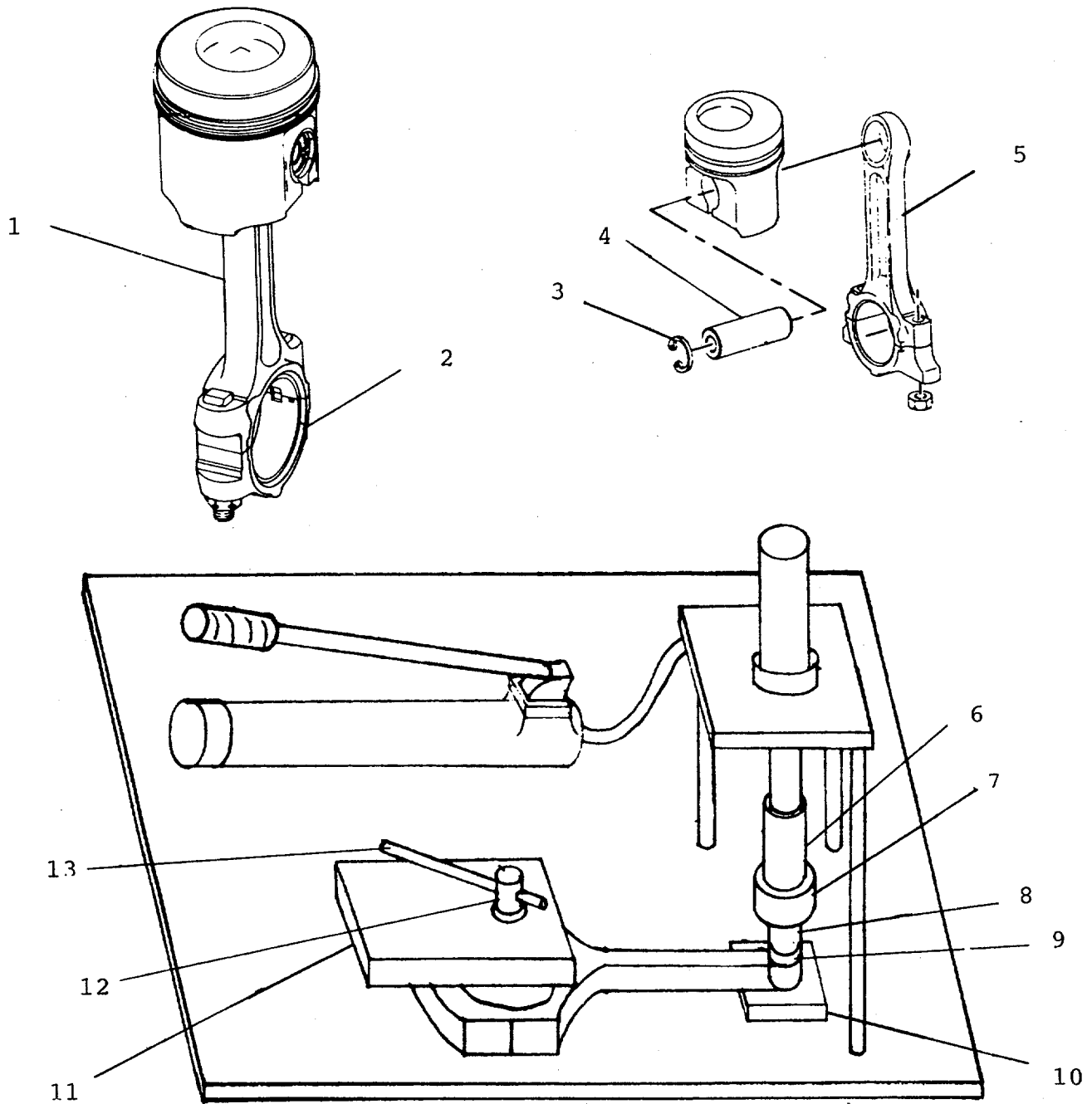

Figure 6-11. Piston and Rod Assembly

NOTE

The old bearing is pushed out as the new bearing is installed. 18. Put 5P8645 adapter (7) in position with taper side down.

18. Put 5P8645 adapter (7) in position with taper side down.

NOTE

The piston pin bearing joint must be in alignment with the hole in adapter (8) and the base plate.

19. Put pusher (6) on adapter (7).
20. Push new piston pin bearing into the connecting rod until adapter (7) makes full contact with connecting rod surface.
21. Remove connecting rod and old piston pin bearing.
22. Check piston pin bearing bore diameter (refer to inspection procedures this paragraph).
23. Install connecting rods (1), Figure 6-10 in the piston with the bearing tab groove on the opposite side of the hole (crater) in top of piston.

NOTE

When old pistons are used, clean the piston grooves.

24. Install piston ring (2).
25. Install snap ring (1).

NOTE

The gap in the ring must be approximately 180 degrees from the oil ring connections.

26. Install the spring for the oil ring.
27. Install oil ring.

CAUTION

When connecting rod caps are installed, make sure that the number on the side of the cap is next to and respective with the number on the side of the connecting rod.

NOTE

The side of the ring that has the identification "top" must be toward the top of the piston.

NOTE

The gaps in the rings must be approximately 120 degrees apart.

NOTE

Compression rings that do not have identification must be installed with the edge that has the bevel toward the top of the piston.

28. Install compression ring.
29. Install connecting rod bearings.
30. Put lubricating oil on piston rings, connecting rod bearings, cylinder walls, and crankshaft bearing journals.
31. Turn crankshaft until bearing journal for pistons to be installed is at bottom center.
32. Install piston in position in same cylinder bore from which it was removed.

NOTE

The hole (crater) in the top of the piston must be toward (nearest) the center of engine.

33. Put lubricating oil on threads of bolts and nuts.
34. Put cap (4) in position on connecting rod.

NOTE

After tightening to 30 lb.-ft., mark nuts and tighten 60 degrees more.

35. Install nuts and tighten to 30 lb.-ft.
36. Check side clearance between two connecting rods on same crankshaft journal. Clearance must be .003 to .033 inch.
37. Do steps 30 through 36 for the remainder of pistons.

6-14. REPAIR LIFT CYLINDER ASSEMBLY

This Task Covers: a. Repair

INITIAL SETUPTools Required

Tool Kit, General Mechanics
(Appendix B, Item 1)

Equipment Conditions

Engine Shutdown (para 2-11).
Battery Disconnected (para 4-58).
Cylinder Removed (para 5-32).

Materials/Parts Required

Cotton Rags (Appendix E,
Item 3)
Cylinder Assembly
P/N TH5036048PA-OO
Packing P/N 10033
Cup P/N 10026
Packing P/N 10055
Retainer P/N 10085
Ring P/N 10714
Seal P/N 10008

Personnel Required

2 Persons

REPAIR (Figure 6-12.)**NOTE**

Cover ends of hoses and cylinder ports (4) immediately upon disconnecting hoses.

1. Remove bolts (6).
2. Use hoist and fasten strap around cylinders.
3. Remove pin (5).
4. Remove bolts (1).
5. Remove pin (2).
6. Remove cylinder assembly (7).
7. Remove end caps (9).
8. Separate outer cylinder (1) by pulling piston rod (6) away.
9. Remove nut (2) from piston rod (6).

10. Remove piston (3) and U-cups (4). Remove O-ring (13).
11. Remove spacer (5) by sliding off piston rod (6).
12. Slide head assembly (8) down and off piston rod (6).
13. Remove O-ring (10) and back-up ring (11).
14. Remove "poly pak" (12) and rod wiper (7).
15. Install poly pak (12) and rod wiper (7).
16. Install O-ring (10).
17. Install back-up ring (11).
18. Slide head assembly onto rod (6).
19. Slide spacer (5) onto rod.
20. Install O-ring (13).
21. Install U-cups (4).
22. Install piston (3).
23. Install nut (2) onto rod (6).
24. Install rod assembly into cylinder (1).
25. Install end caps (9).
26. Install cylinder assembly (7), Figure 5-29.
27. Install pin (2).
28. Install and tighten bolts (1).
29. Install pin (5).
30. Install bolts (6).
31. Install hoses (3).

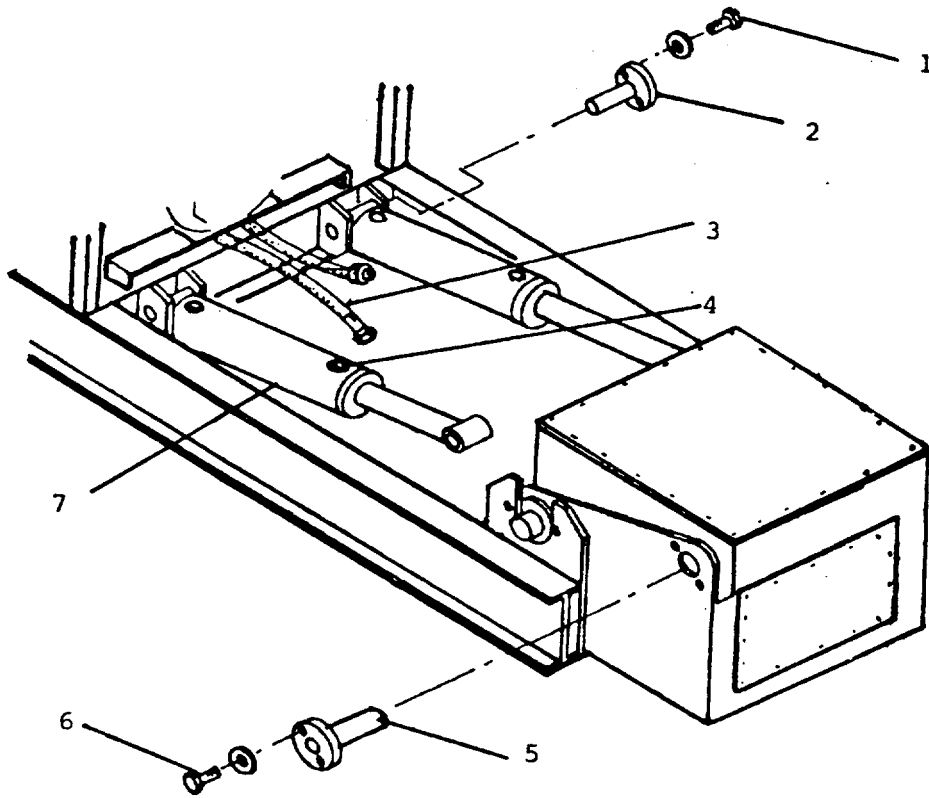

Figure 6-12 (1 of 2). Lift Assembly.

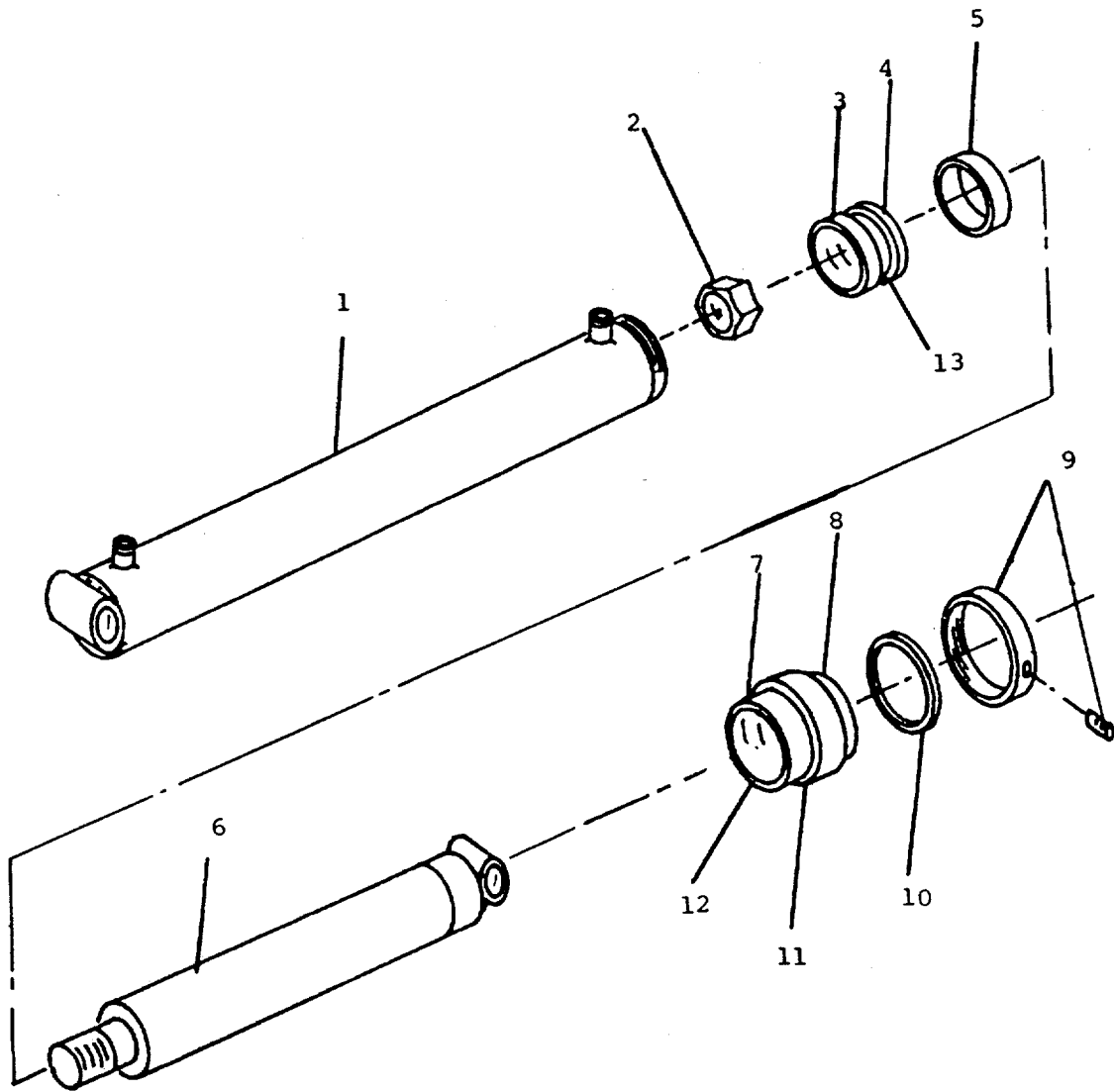

Figure 6-12 (2 of 2). Lift Assembly.

Section III. PREPARATION FOR SHIPMENT OR STORAGE.

6-15. Refer to paragraph 4-68. Section VI.

6-43/(6-44 blank)

APPENDIX A

REFERENCES

A-1. Scope. This paragraph lists the manuals, bulletins, specifications, and miscellaneous publications referenced in this manual or required for maintenance activities.

A-2. Field Manuals.

FM 21-11	First Aid for Soldiers
FM 31-70	Basic Cold Weather Manual
FM 55-501	Marine Crewman's Handbook

A-3. Technical Manuals.

L05-2010-205-12	Lubrication Order for Propelling Unit
TM 5-2010-205-24P	Organizational, Direct Support, and General Support Maintenance Repair Parts and Special Tools List

TM 750-244-3	Destruction of Army Material to Prevent Enemy Use
--------------	--

A-4. Miscellaneous Publications.

DA PAM 738-750	The Army Maintenance Management System (TAMMS)
AR 750-10	Maintenance of Supplies and Equipment

A-5. Forms.

SF Form 368	Quality Deficiency Report
DA Form 2028	Recommended Changes to Publications and Blank Forms
DA Form 2028-2	Recommended Changes to Equipment Technical Publications
DA Form 2404	Equipment Inspection and Maintenance Worksheet
DA Form 2407	Maintenance Request

A-1/(A-2 blank)

APPENDIX B

MAINTENANCE ALLOCATION CHART

Section I. INTRODUCTION

B-1. GENERAL

- a. This section provides a general explanation of all maintenance and repair functions authorized at various maintenance levels.
- b. The Maintenance Allocation Chart (MAC) in section II designates overall responsibility for the performance of maintenance functions on the identified and item or component and the work measurement time required to perform the functions upon the end item or component will be consistent with the assigned maintenance functions.

B-2. MAINTENANCE FUNCTIONS

- a. **Inspect.** To determine the serviceability of an item by comparing its physical, mechanical, and/or electrical characteristics with established standards through examination.
- b. **Test.** To verify serviceability and detect incipient failure by measuring the mechanical or electrical characteristics of an item and comparing those characteristics with prescribed standards.
- c. **Service.** Operations required periodically to keep an item in proper operating condition, i.e., to clean (decontaminate), to preserve, to drain, to paint, or to replenish fuel, lubricants, hydraulic fluids or compressed air supplies.
- d. **Adjust.** To maintain, within prescribed limits, by bringing into proper or exact position, or by setting the operating characteristics to specified parameters.
- e. **Align.** To adjust specified variable elements of an item about optimum or desired performance.
- f. **Calibrate.** To determine and cause corrections to be made or to be adjusted on instruments or test, measuring and diagnostic equipment used in precision measurement. Consists of comparisons of two instruments one of which is a certified standard of known accuracy, to detect and adjust any discrepancy in the accuracy of the instrument being compared.
- g. **Install.** The act of implacing, seating, or fixing into position an item, part, or module (component or assembly) in a manner to allow the proper functioning of an equipment or system.

h. Replace. The act of substituting a serviceable like part, subassembly, or module (component or assembly) for an unserviceable counterpart.

i. Repair. The application of maintenance services or other maintenance actions to restore serviceability to an item by correcting specific damage, fault, malfunction, or failure in a part, subassembly, module (component or assembly), end item, or system.

j. Overhaul. That maintenance effort (services/actions) necessary to restore an item to a completely serviceable/operational condition as prescribed by maintenance standards (i.e., DMWR) in appropriate technical publications. Overhaul is normally the highest degree of maintenance performed by the Army. Overhaul does not normally return an item to like new condition.

k. Rebuild. Consists of those services/actions necessary for the restoration of unserviceable equipment to a like new condition in accordance with original manufacturing standards. Rebuild is the highest degree of material maintenance applied to Army equipment. The rebuild operation includes the act of returning to zero those age measurements (hours/miles, etc.) considered in classifying Army equipment/components.

B-3. EXPLANATION OF COLUMNS IN THE MAC, SECTION II.

a. Column 1, Group Number. Column 1 lists group numbers, the purpose of which is to identify components, assemblies, subassemblies, and modules with the next higher assembly.

b. Column 2, Component/Assembly. Column 2 contains the names of components, assemblies, subassemblies, and modules for which maintenance is authorized.

c. Column 3, Maintenance Functions. Column 3 lists the functions to be performed on the item listed in column 2. (For detailed explanation of these functions, see para. B-2).

d. Column 4, Maintenance Level. Column 4 specifies, by the listing of a "work time" figure in the appropriate subcolumn(s), the lowest level of maintenance authorized to perform the maintenance function at the indicated level of maintenance. If the number of complexity of the tasks within figures will be shown for each level. The number of man-hours specified by the "work-time" figure represents the average time required to restore an item (assembly, subassembly, component, module, end item, or system) to a serviceable condition under typical field operating conditions. This time includes preparation time, troubleshooting time, and quality assurance/quality control time in addition to the time required to perform the specific tasks identified for the maintenance functions authorized in the maintenance allocation chart. The symbol designations for the various maintenance levels are as follows:

- C. Operator or crew.
- O. Organization maintenance.
- F. Direct support maintenance.
- H. General support maintenance.
- D. Depot maintenance.

e. Column 5, Tools and Equipment. Column 5 specifies, by code, those common tools sets (not individual tools) and special tools, TMDE, and support equipment required to perform the designated function.

f. Column 6, Remarks. This column shall, when applicable, contain letter code, in alphabetic order, which shall be keyed, to the remarks contained in Section IV.

Section II. MAINTENANCE ALLOCATION CHART

(1) GROUP NUMBER	(2) COMPONENT ASSEMBLY	(3) MAINTENANCE FUNCTION	(4) MAINTENANCE CATEGORY					(5) TOOLS AND EQUIP	(6) REMARKS
			Unit		Direct	General	Depot		
			C	O	F	H	D		
00	PROPELLING UNIT	INSPECT SERVICE TEST ADJUST REPAIR OVERHAUL	0.5 2.5		4.0 2.0 8.0	16.0 48.0		1,2,3,4 5,6,7,8 9,10	
01	POWER UNIT								
0010	FRAMEWORK ASSEMBLY	INSPECT REPAIR REPLACE	0.3		3.0 1.0			1,2 1	
0102	ENGINE ASSEMBLY	INSPECT SERVICE TEST ADJUST REPAIR REPLACE	1.0 2.5		4.0 3.0 16.0 4.0	20.0		1,2,3,4 5,6,7,8 9,10	
010201	COOLER ASSEMBLY (OIL)	INSPECT REPLACE REPAIR	0.5	1.0	4.0			1 2	

Section II. MAINTENANCE ALLOCATION CHART

(1) Group Number	(2) Component/ Assembly	(3) Maintenance Function	(4) Maintenance Level					(5) Tools and Equipment	(6) Remarks
			Unit		Direct	General	Depot		
			C	O	F	H	D		
010202	OIL PUMP ASSEMBLY	INSPECT REPAIR	1.0		2.0			1, 2	
010203	TURBOCHARGER ASSEMBLY	INSPECT REPLACE REPAIR	0.2		2.0 2.0	4.0		1, 2, 8 1, 2, 8	
010204	MANIFOLD ASSEMBLY	INSPECT REPLACE REPAIR	0.1		2.0 2.0			1 2	
010205	EXPANSION TANK ASSEMBLY	INSPECT TEST REPLACE REPAIR	0.1		0.3			1 2	
010206	FUEL PRIME PUMP ASSEMBLY	INSPECT REPLACE	0.2	1.0				2	
010207	OIL PAN ASSEMBLY	INSPECT REPLACE REPAIR	0.2		2.0 0.3			1 2	
010208	OIL LEVEL GAUGE ASSEMBLY	INSPECT REPLACE	0.1	0.2				1	
010209	GOVERNOR CONTROL ASSEMBLY	INSPECT REPLACE		0.3	1.0			2	
010210	FLYWHEEL HOUSING ASSEMBLY	INSPECT REPLACE	0.3		3.0			2, 4, 10	
010211	FUEL FILTER ASSEMBLY	INSPECT SERVICE REPLACE	0.1 0.2	0.5				1 2	

Section II. MAINTENANCE ALLOCATION CHART

(1) Group Number	(2) Component/ Assembly	(3) Maintenance Function	(4) Maintenance Level					(5) Tools and Equipment	(6) Remarks
			Unit		Direct	General	Depot		
			C	O	F	H	D		
010212	GOVERNOR DRIVE ASSEMBLY	INSPECT REPLACE REPAIR				0.5 1.0 1.0		1 2	
010213	SEAWATER EXCHANGER ASSEMBLY	INSPECT TEST REPLACE REPAIR	0.2			0.3 2.5		1 2	
010214	WATER LINES	INSPECT REPLACE	0.1	0.5				1, 2	
010215	CONNECTION ASSEMBLY	INSPECT REPAIR REPLACE	0.1	0.5 0.5				1, 2 1, 2	
010216	AUXILIARY LINES	INSPECT REPLACE REPAIR	0.1	0.5 0.5				1, 2 1, 2	
010217	GOVERNOR PUMP ASSEMBLY	INSPECT REPLACE	0.2		2.0			1, 2	
010218	FLYWHEEL ASSEMBLY	INSPECT REPLACE			1.5 3.5			2	
010219	FUEL INJECTION LINES ASSEMBLY	INSPECT REPLACE		0.1 3.0				3	
010222	FRONT HOUSING ASSEMBLY	INSPECT REPLACE REPAIR			2.0	6.0 2.0		1, 2, 4 2, 4	
010221	MECHANICAL COVER ASSEMBLY	INSPECT REPLACE		0.1 0.3				2, 4	

Section II. MAINTENANCE ALLOCATION CHART

(1) Group Number	(2) Component/ Assembly	(3) Maintenance Function	(4) Maintenance Level					(5) Tools and Equipment	(6) Remarks
			Unit		Direct	General	Depot		
			C	O	F	H	D		
010222	AIR LINES ASSEMBLY	INSPECT REPLACE	0.2	0.3				2, 4	
010223	OIL FILTER ASSEMBLY	INSPECT SERVICE REPLACE REPAIR	0.1 0.4	0.5 0.3				1 1, 2	
010224	PCV LINES ASSEMBLY	INSPECT REPLACE REPAIR	0.1	2.0 0.5				1 1, 2	
010225	LIFTING ASSEMBLY	INSPECT REPLACE	0.1	0.4				2	
010226	TURBOCHARGER LINES ASSEMBLY	INSPECT REPLACE REPAIR	0.1	0.4 1.5				2 2, 4	
010227	ENGINE OIL LINES ASSEMBLY	INSPECT REPLACE	0.1	0.5				2	
010228	FASTENER ASSEMBLY	INSPECT REPLACE		0.2	2.0			1	
010229	CRANKSHAFT SEAL ASSEMBLY	INSPECT REPLACE				0.5 6.0		2, 4	
010230	CAMSHAFT ASSEMBLY	INSPECT REPLACE				1.0 7.0		2, 4, 10	
010231	CYLINDER HEAD ASSEMBLY	INSPECT REPLACE REPAIR		0.3	4.0 8.0			2 2, 4, 10	
010232	VALVE MECHANISM ASSEMBLY	INSPECT REPLACE REPAIR ADJUST		0.6	1.5 1.5 1.0			2 2, 4 2	

Section II. MAINTENANCE ALLOCATION CHART

(1) Group Number	(2) Component/ Assembly	(3) Maintenance Function	(4) Maintenance Level					(5) Tools and Equipment	(6) Remarks
			Unit		Direct	General	Depot		
			C	O	F	H	D		
010233	MANIFOLD ASSEMBLY	INSPECT REPLACE		0.1 2.0				2, 4	
010234	WATER PUMP ASSEMBLY	INSPECT REPLACE REPAIR	0.1	1.5 2.0				2 2, 4, 9	
010235	ENGINE SUPPORT ASSEMBLY	INSPECT REPLACE	0.2		1.5			1, 2	
010236	PULLEY AND DAMPER ASSEMBLY	INSPECT REPLACE	0.2	1.5				2	
010237	CRANKSHAFT ASSEMBLY	INSPECT REPLACE				0.5 6.0		2, 4	
010238	CYLINDER BLOCK ASSEMBLY	INSPECT REPLACE REPAIR			1.0	16.0 8.0		2, 4 2, 4	
010239	PISTON AND ROD ASSEMBLY	INSPECT REPLACE REPAIR				1.5 2.0 1.0		2, 4 2, 4, 10	
010240	STARTER MOTOR ASSEMBLY	INSPECT REPLACE REPAIR	0.2	1.5	3.0			2 2	
010241	WIRING ASSEMBLY	INSPECT REPLACE	0.2	1.5				2	
010242	ALTERNATOR ASSEMBLY	INSPECT REPLACE	0.2	1.0				2	
010243	AUXILIARY PUMP ASSEMBLY	INSPECT REPLACE	0.1	2.0				2	

Section II. MAINTENANCE ALLOCATION CHART

(1) Group Number	(2) Component/ Assembly	(3) Maintenance Function	(4) Maintenance Level					(5) Tools and Equipment	(6) Remarks
			Unit		Direct	General	Depot		
			C	O	F	H	D		
010244	GUARD ASSEMBLY	INSPECT REPLACE	0.1	2.0				1, 2	
010245	AIR INTAKE FILTER ASSEMBLY	INSPECT SERVICE REPLACE	0.2 0.3					1, 2	
010246	MUFFLER AND PIPE ASSEMBLY	INSPECT REPLACE	0.2	2.0				1, 2	
0103	HYDRAULIC PUMP ASSEMBLY	INSPECT REPLACE REPAIR	0.2		3.0 3.0			2, 4 2, 4	
0104	CONTROL PANEL ASSEMBLY	INSPECT	0.2		4.0			2, 4	
0105	HEAT EXCHANGER ASSY (HYDRAULIC OIL)	INSPECT REPLACE REPAIR	0.1	3.0	4.0			2 2, 4	
0106	ELECTRIC WIRING ASSEMBLY	INSPECT REPLACE REPAIR	0.1		2.0 1.0			2 2, 4	
0107	HYDRAULIC HOSE VALVE ASSEMBLY	INSPECT REPLACE REPAIR	0.5	3.0	2.0 2.0			1, 2 2, 4	
0108	HYDRAULIC RESERVOIR ASSEMBLY	INSPECT SERVICE REPLACE REPAIR	0.1 0.1	2.0 1.0				2 2, 4	
0109	SEAWATER COOLING ASSEMBLY	INSPECT SERVICE REPLACE REPAIR	0.1 0.1	2.0 2.0				2 2, 4	

Section II. MAINTENANCE ALLOCATION CHART

(1) Group Number	(2) Component/ Assembly	(3) Maintenance Function	(4) Maintenance Level					(5) Tools and Equipment	(6) Remarks
			Unit		Direct	General	Depot		
			C	O	F	H	D		
0110	BATTERY ASSEMBLY	INSPECT SERVICE REPLACE	0.1 1.0 1.0					1 1, 2	
0111	SQUIRREL CAGE FAN ASSEMBLY	INSPECT REPLACE REPAIR	0.2	2.0 2.0				2 2, 4	
0112	HAND DRIVEN PUMP ASSEMBLY	INSPECT REPLACE	0.1	2.0				1	
02	OUTDRIVE ASSEMBLY								
0201	UPPER OUTDRIVE HOUSING ASSEMBLY	INSPECT SERVICE REPLACE REPAIR	0.3 0.5		2.0 8.0			1 1, 2 2, 4	
020101	STEERING MOTOR ASSEMBLY	INSPECT REPLACE	0.2	2.0				1, 2	
020102	DIRECTION INDICATOR ASSEMBLY	INSPECT ADJUST REPLACE REPAIR	0.1 0.2	2.0 1.0				1 1, 2 2, 4	
0202	LOWER UNIT ASSEMBLY	INSPECT REPLACE REPAIR	0.1		2.0 3.0			1, 2 2, 4	
03	LIFT CYLINDER ASSEMBLY	INSPECT REPLACE REPAIR	0.1		2.0	3.0		2 2, 4	
04	CONNECTING ELECTRICAL ASSEMBLY	INSPECT REPLACE	0.1	0.5				1	
05	CONNECTING HYDRAULIC HOSE ASSEMBLY	INSPECT REPLACE	0.2	1.0				2	

**Section III. TOOL AND TEST EQUIPMENT REQUIREMENTS
FOR
PROPULSION UNIT, OUTBOARD**

TOOL OR TEST EQUIPMENT REF CODE	MAINTENANCE LEVEL	NOMENCLATURE	NATIONAL/NATO STOCK NUMBER	TOOL NUMBER
1	C, F, H	Tool Kit, General Mechanics: rail and marine diesel engine	5180-00-629-9783	
2	F, H, O	Shop equipment, automobile maintenance and repair common No. 2	4910-00-754-0650	
3	F, H	Tool kit, automatic, fuel and electrical systems repair	5180-00-754-0655	
4	H	Shop equipment, general purpose repair, semi-trailer mounted	4940-00-287-4894	
5	F, H	Puller		5P2371
6	F, H	Timing pin		3P1544
7	F, H	Cooling system pressurizing pump group		9S8140
8	F, H	Turbocharger fixture group		9S6363
9	F, H	Puller assembly		5F7465
10	F, H	Dial test indicator group		8S2328
11	F, H, O	Puller assembly		8B7548
12	H	Pulling attachment		8B7551
13	H	Puller		1P3075
14	F, H	Drive assembly		8S2285
15	F, H	Fixture assembly		9S6343
16	F, H	Valve spring compressor		5S1330
17	F, H	Valve seat insert puller		8S7170

**Section III. TOOL AND TEST EQUIPMENT REQUIREMENTS
FOR
PROPULSION UNIT, OUTBOARD**

TOOL OR TEST EQUIPMENT REF CODE	MAINTENANCE LEVEL	NOMENCLATURE	NATIONAL/NATO STOCK NUMBER	TOOL NUMBER
18	H	Installer		5P7293
19	H	Puller		1P2321
20	H	Spacer		8S5579
21	H	Spacer		9S9155
22	F, H	Bolt		0S1616
23	H	Locator		5P0290
24	H	Bolt		1P5515
25	H	Nut		9S8858
26	H	Bearing tool		2P5518
27	H	Ridge reamer		8S2269
28	H	Ring compressor		5P3524
29	H	Piston ring groove cleaner		8S2304
30	H	Ring expander		5F9059
31	H	Press group		5P8639
32	H	Hose assembly		8F0024
33	H	Coupler assembly		1P2375
34	H	Coupler assembly		1P2376
35	H	Hand pump		5P8719

APPENDIX C

COMPONENTS OF END ITEM AND
BASIC ISSUE ITEMS LIST

Section I. Introduction

C-1. SCOPE. This appendix lists components of end items and basic issue items for the Propelling Unit to help you inventory items required for safe and efficient operation.

C-2. GENERAL. The components of End Item and Basic Issue Items Lists are divided into the following sections:

- a. Section II. Components of End Items. Not Applicable.
- b. Section III. Basic Issue Items. These are minimum essential items required to place the Propelling Unit in operation, to operate it, and to perform emergency repairs. The illustrations will assist you with hard-to-identify items. This manual is your authority to request/requisition replacement BII, based on TOE/MTOE authorization of the end item.

C-3. EXPLANATION OF COLUMNS. The following provides an explanation of columns found in the tabular listings:

a. Column (1). Illustration Number (Illus. Number). This column indicates the number of the illustration in which the item is shown.

b. Column (2). National Stock Number. Indicates the national stock number assigned to the item and will be used for requisitioning purposes.

c. Column (3). Description. Indicates the Federal item name and if required, a minimum description to identify and locate the item. The last line for each item indicates the CAGE (in parentheses) followed by the part number.

d. Column (4). Unit of Measure (U/M). Indicates the measure used in performing the actual operation/maintenance function. This measure is expressed by a two-character alphabetical (e.g., ea, in, pr).

e. Column (5). Quantity Required (Qty rqr). Indicates the quantity of the item authorized to be used with/on the equipment.

Section II. COMPONENTS OF END ITEM

NOT APPLICABLE

Section III. BASIC ISSUE ITEMS

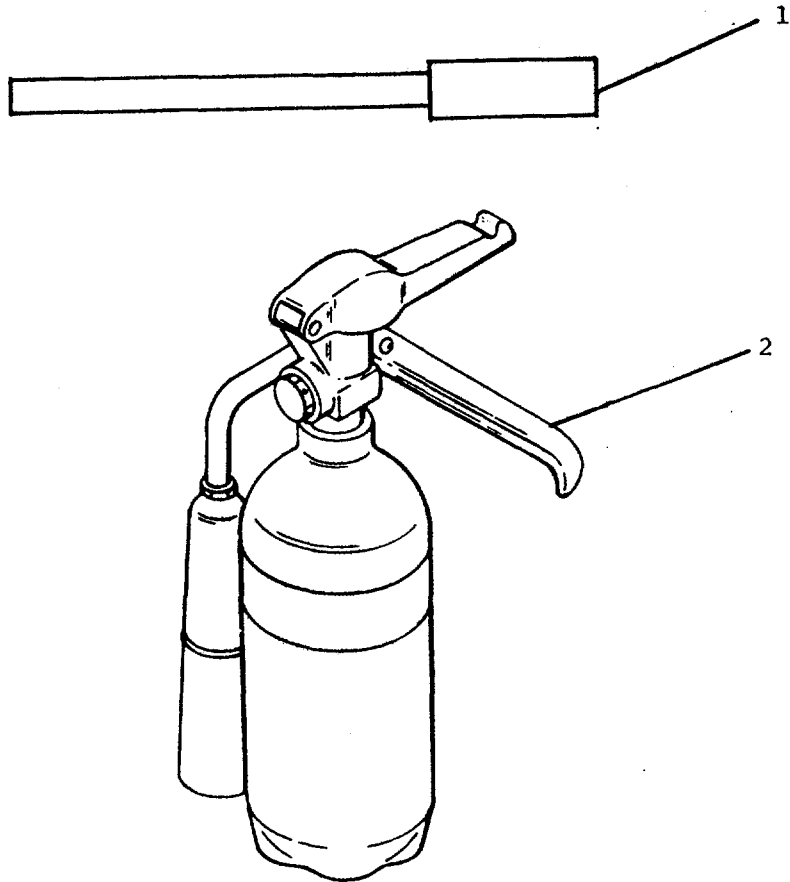

Illus Number	National Stock Number	Description CAGE and Part Number	U/M	Qty Reqd
1		Handle, Lever (98745) CP13-23	EA	1
2		Extinguisher, fire	EA	1
NA	7520-00-559-9618	Case, manuals (81348) MIL-C-11743	EA	1
NA	No NSN	Technical Manual, TM 5-2010-205-14	EA	1

APPENDIX D

ADDITIONAL AUTHORIZATION LIST

Section I. Introduction

D-1. SCOPE. This appendix lists additional items you are authorized for the support of the Propelling Unit.

D-2. GENERAL. This list identifies items that do not have to accompany the Propelling Unit and that do not have to be turned in with it. These items are all authorized to you by CTA, MTOE, TDA, or JTA.

D-3. EXPLANATION OF LISTING. National stock numbers, descriptions, and quantities are provided to help you identify and request the additional items you require to support the equipment. The items are listed in alphabetical sequence by item name under the type document (i.e., CTA, MTOE, TDA, or JTA) which authorizes the item(s) to you.

Section II. ADDITIONAL AUTHORIZATION LIST

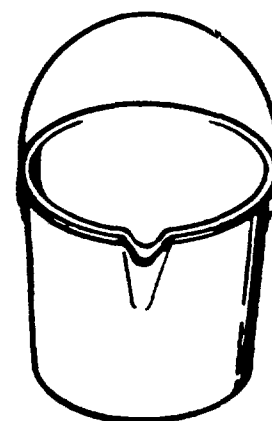
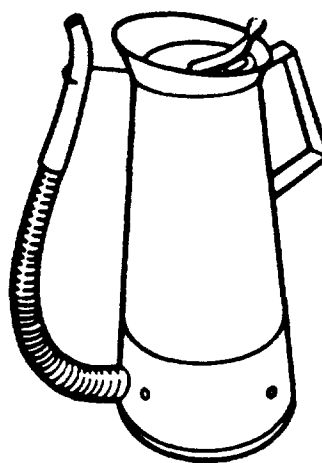
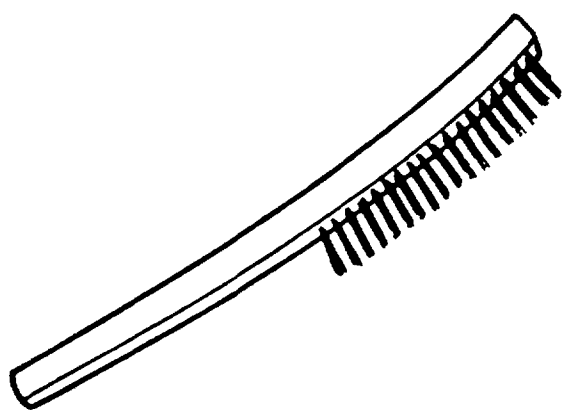

National Stock Number	Description CAGE and Part Number	U/M	Qty Auth
7240-00-160-0455	Pail, metal (81348) A-A-1273	EA	2
7920-00-291-5815	Brush, wire scratch (81348) H-B-178	EA	2
	Strap, nylon	EA	1
7240-00-255-8113	Measure, liquid (81348) A-A-1607	EA	AR

APPENDIX E

EXPENDABLE/DURABLE SUPPLIES AND MATERIAL LIST

Section I. INTRODUCTION

E-1. SCOPE. This appendix lists expendable supplies and materials you will need to operate and maintain the Propelling Unit. This listing is for information purposes only and is not authority to requisition the listed items. These items are authorized to you by CTA 50-970, Expendable/Durable Items (except Medical, Class V, Repair Parts, and Heraldic Items), or CTA 8-100, Army Medical Department Expendable/Durable Items.

E-2. EXPLANATION OF COLUMNS.

a. Column (1). Item Number. This number is assigned to the entry in the listing and is referenced in the narrative instruction to identify the materials.

b. Column (2). Level. This column identifies the lowest level of maintenance that requires the listed item.

O-Organizational Maintenance
F-Direct Support Maintenance

c. Column (3). National Stock Number. This number is the national stock number assigned to the item; use it to request or requisition the item.

d. Column (4). Description. Indicates the Federal item name and, if required, a description to identify the item. The last line of each item indicates the Commercial and Government Entity Code (CAGE) in parentheses followed by the part number.

e. Column (5). Unit of Measure (U/M). Indicates the measure used in performing the actual maintenance function. This measure is expressed by a two-character alphabetical abbreviation (e.g., ea, in, pr). If the unit of measure differs from the unit of issue, requisition the lowest unit of issue that will satisfy your requirements.





Section II. EXPENDABLE/DURABLE SUPPLIES AND MATERIAL LIST

Item Number	Level	National Stock Number	Description CAGE and Part Number	U/M
1	O, F	6850-00-264-9038	Cleaning Solvent (P-D-680)	EA
2	O, F	9150-00-265-9433	Lubricating Oil (30W)	QT
3	O, F	7920-00-205-1711	Cotton Rags	BL
4	O, F	6850-00-664-1403	Permanent Antifreeze	GAL
5	O, F	6850-00-965-2082	Cooling System Cleaner	BX
6	O, F	8030-00-252-3391	Gasket Sealing Compound	TU
7	F	7510-00-290-2024	Cooling System Conditioner (11083) 3P2044	QT
8	O	7510-00-290-2024	Masking Tape, 3/4" wide	RO

APPENDIX F

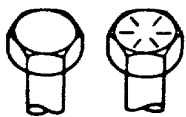
TORQUE TABLE

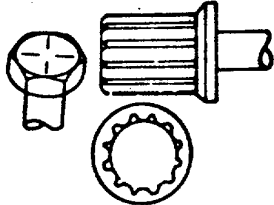
STANDARD CAPSCREW MARKINGS AND TORQUE

Current Usage	Much Used	Much Used	Used at Times	Used at Times
Minimum Tensile Strength PSI MPa	To 1/2-69,000 (476) To 3/4-64,000 (421) To 1-55,000 (379)	To 3/4-120,000 (827) To 1-115,000 (793)	To 5/8-140,000 (965) To 3/4-133,000 (917)	150,000 (1034)
Quality of Material	Indeterminate	Minimum Commercial	Medium Commercial	Best Commercial
SAE Grade Number	1 or 2	5	6 or 7	8
Capscrew Head Markings Manufacturer's marks may vary				
These are all SAE Grade 5 (3 line)				
Capscrew Body Size (Inches)—(Thread)	Torque Ft-Lb (N-m)	Torque Ft-Lb (N-m)	Torque Ft-Lb (N-m)	Torque Ft-Lb (N-m)
1/4—20	5(7)	8(11)	10(14)	12(16)
—28	6(8)	10(14)		14(19)
5/16—18	11(15)	17(23)	19(26)	24(33)
—24	13(18)	19(26)		27(37)
3/8—16	18(24)	31(42)	34(46)	44(60)
—24	20(27)	35(47)		49(66)
7/16—14	28(38)	49(66)	55(75)	70(95)
—20	30(41)	55(75)		78(106)
1/2—13	39(53)	75(102)	85(115)	105(142)
—20	41(56)	85(115)		120(163)
9/16—12	51(69)	110(149)	120(163)	155(210)
—18	55(75)	120(163)		170(231)
5/8—11	83(113)	150(203)	167(228)	210(285)
—18	95(129)	170(231)		240(325)
3/4—10	105(142)	270(366)	280(380)	375(508)
—16	115(156)	295(400)		420(569)
7/8—9	160(217)	395(536)	440(597)	605(820)
—14	175(237)	435(590)		675(915)
1—8	235(319)	590(800)	660(895)	910(1234)
—14	250(339)	650(895)		990(1342)

1. Always use the torque values listed above when definite specifications are not available.

Note: Do not use standard values in place of those specified in other sections of this manual; special attention should be observed when using SAE Grade 6, 7 and 8 capscrews.

2. The above is based on use of clean and dry threads.

3. Reduce torque by 10% when engine oil is used as a lubricant.

4. Reduce torque by 20% if new plated capscrews are used.

Caution: Capscrews threaded into aluminum may require reductions in torque of 30% or more, unless inserts are used.

ALPHABETICAL INDEX

Subject Paragraph

A

Air Intake Filter Assembly	
Inspect.....	4-49
Service.....	4-49
Replacement.....	4-49
Air Lines Assembly	
Inspect.....	4-31
Replacement.....	4-31
Alternator Assembly	
Inspect.....	4-46
Replacement.....	4-46
Auxilliary Lines	
Inspect.....	4-27
Replacement.....	4-27
Repair.....	4-27
Auxilliary Pump Assembly	
Inspect.....	4-47
Replacement.....	4-47

B

Battery Assembly	
Inspect.....	4-58
Service.....	4-58
Replacement.....	4-58

C

Camshaft Assembly	
Inspect.....	6-10
Replacement.....	6-10
Connecting Hydraulic Hose Assembly	
Inspect.....	4-67
Replacement.....	4-67
Connection Assembly	
Inspect.....	4-26
Repair.....	4-26
Replacement.....	4-26
Cooler Assembly (Oil)	
Inspect.....	4-13
Replacement.....	4-13
Repair.....	5-7
Control Panel Assembly	
Inspect.....	4-52
Repair.....	5-26

Subject	Paragraph
Crankshaft Assembly	
Inspect.....	6-11
Replacement	6-11
Crankshaft Seal Assembly	
Inspect.....	6-9
Replacement	6-9
Cylinder Block Assembly	
Inspect.....	5-23
Replacement	6-12
Repair.....	6-12
Cylinder Head Assembly	
Inspect.....	4-38
Replacement	5-20
Repair.....	5-20

D

Direction Indicator Assembly	
Inspect.....	4-63
Adjust	4-63
Replacement	4-63
Repair.....	4-63

E

Electric Wiring Assembly	
Inspect.....	4-54
Replacement	5-28
Repair.....	5-28
Electrical Assembly	
Inspect.....	4-66
Replacement	4-66
Engine Assembly	
Inspect.....	4-12
Service.....	4-12
Test	5-6
Adjust	5-6
Repair.....	4-12, 5-6, 6-5
Replacement	5-6
Engine Oil Lines Assembly	
Inspect.....	4-36
Replacement	4-36
Engine Support Assembly	
Inspect.....	4-42
Replacement	5-22
Expansion Tank Assembly	
Inspect.....	4-17
Test	5-11
Replacement	4-17
Repair.....	4-17

Subject	Paragraph
F	
Fastener Assembly	
Inspect.....	4-37
Replacement	5-19
Flywheel Assembly	
Inspect.....	5-17
Replacement	5-17
Flywheel Housing Assembly	
Inspect.....	4-22
Replacement	5-14
Framework Assembly	
Inspect.....	4-11
Repair.....	5-5
Replacement	5-5
Front Housing Assembly	
Inspect.....	5-18
Replacement	6-7
Repair.....	6-7
Fuel Filter Assembly	
Inspect.....	4-23
Service	4-23
Replacement	4-23
Fuel Injection Lines Assembly	
Inspect.....	4-29
Replacement	4-29
Fuel Prime Pump Assembly	
Inspect.....	4-18
Replacement	4-18
G	
Governor Control Assembly	
Inspect.....	4-21
Replacement	5-13
Governor Drive Assembly	
Inspect.....	6-8
Replacement	6-8
Repair.....	6-8
Governor Pump Assembly	
Inspect.....	4-28
Replacement	5-16
Guard Assembly	
Inspect.....	4-48
Replacement	4-48
H	
Hand Driven Pump Assembly	
Inspect.....	4-60
Replacement	4-60
Heat Exchanger Assembly	
Inspect.....	4-53

Subject	Paragraph
Replacement	4-53
Repair.....	5-27
Hydraulic Hose and Valve Assembly	
Inspect.....	4-55
Replacement	4-55, 5-29
Repair.....	5-29
Hydraulic Pump Assembly	
Inspect.....	4-51
Replacement	5-25
Repair.....	5-25
Hydraulic Reservoir Assembly	
Inspect.....	4-56
Service.....	4-56
Replacement	4-56
Repair.....	4-56

L

Lifting Assembly	
Inspect.....	4-34
Replacement	4-34
Lift Cylinder Assembly	
Inspect.....	4-65
Repair.....	6-14
Replacement	5-32
Lower Unit Assembly	
Inspect.....	4-64
Repair.....	5-31
Replacement	5-31

M

Manifold Assembly	
Inspect.....	4-16
Repair.....	5-10
Replacement	4-40, 5-10
Mechanical Cover Assembly	
Inspect.....	4-30
Replacement	4-30
Muffler and Pipe Assembly	
Inspect.....	4-50
Replacement	4-50

O

Oil Filter Assembly	
Inspect.....	4-32
Service.....	4-32
Replacement	4-32
Repair.....	4-32
Oil Level Gauge Assembly	
Inspect.....	4-20

Subject	Paragraph
Replacement	4-20
Oil Pan Assembly	
Inspect.....	4-19
Replacement	5-12
Repair.....	5-12
Oil Pump Assembly	
Inspect.....	4-14
Repair.....	5-8

P

PVC Lines Assembly	
Inspect.....	4-33
Replacement	4-33
Repair.....	4-33
Piston and Rod Assembly	
Inspect.....	6-13
Replacement	6-13
Repair.....	6-13
Propelling Unit	
Inspect.....	4-10
Service.....	4-10
Test	5-4
Adjust	4-10, 5-4
Repair.....	4-10, 5-4, 6-4
Overhaul	6-4
Pulley and Damper Assembly	
Inspect.....	4-43
Replacement	4-43

S

Seawater Cooling Assembly	
Inspect.....	4-57
Service.....	4-57
Replacement	4-57
Repair.....	4-57
Seawater Exchanger Assembly	
Inspect.....	4-24
Test	5-15
Replacement	4-24
Repair.....	5-15
Squirrel Cage Fan Assembly	
Inspect.....	4-59
Replacement	4-59
Repair.....	4-59
Starter Motor Assembly	
Inspect.....	4-44
Replacement	4-44
Repair.....	5-24

Subject	Paragraph
Steering Motor Assembly	
Inspect.....	4-62
Replacement	4-62

T

Turbocharger Assembly	
Inspect.....	4-15
Replacement	5-9
Repair.....	5-9, 6-6
Turbocharger Lines Assembly	
Inspect.....	4-35
Replacement	4-35
Repair.....	4-35

U

Upper Outdrive Assembly	
Inspect.....	4-61
Service	4-61
Replacement	5-30
Repair.....	5-30

V

Valve Mechanism Assembly	
Inspect.....	4-39
Adjust	5-21
Replacement	5-21
Repair.....	5-21

W

Water Lines	
Inspect.....	4-25
Replacement	4-25
Water Pump Assembly	
Inspect.....	4-41
Replacement	4-41
Repair.....	4-41
Wiring Assembly	
Inspect.....	4-45
Replacement	4-45

By Order of the Secretary of the Army:

CARL E. VUONO
General, United States Army
Chief of Staff

Official:

PATRICIA P. HICKERSON
Colonel, United States Army
The Adjutant General

DISTRIBUTION:

To be distributed in accordance with DA Form 12-25A, Operator, Unit, Direct Support and General Support Maintenance requirements for Propelling Unit, Outboard, Diesel, 165 HP, Model NAV-165.

The Metric System and Equivalents

Linear Measure

1 centimeter = 10 millimeters = .39 inch
 1 decimeter = 10 centimeters = 3.94 inches
 1 meter = 10 decimeters = 39.37 inches
 1 dekameter = 10 meters = 32.8 feet
 1 hectometer = 10 dekameters = 328.08 feet
 1 kilometer = 10 hectometers = 3,280.8 feet

Weights

1 centigram = 10 milligrams = .15 grain
 1 decigram = 10 centigrams = 1.54 grains
 1 gram = 10 decigram = .035 ounce
 1 dekagram = 10 grams = .35 ounce
 1 hectogram = 10 dekagrams = 3.52 ounces
 1 kilogram = 10 hectograms = 2.2 pounds
 1 quintal = 100 kilograms = 220.46 pounds
 1 metric ton = 10 quintals = 1.1 short tons

Liquid Measure

1 centiliter = 10 milliliters = .34 fl. ounce
 1 deciliter = 10 centiliters = 3.38 fl. ounces
 1 liter = 10 deciliters = 33.81 fl. ounces
 1 dekaliter = 10 liters = 2.64 gallons
 1 hectoliter = 10 dekaliters = 26.42 gallons
 1 kiloliter = 10 hectoliters = 264.18 gallons

Square Measure

1 sq. centimeter = 100 sq. millimeters = .155 sq. inch
 1 sq. decimeter = 100 sq. centimeters = 15.5 sq. inches
 1 sq. meter (centare) = 100 sq. decimeters = 10.76 sq. feet
 1 sq. dekameter (are) = 100 sq. meters = 1,076.4 sq. feet
 1 sq. hectometer (hectare) = 100 sq. dekameters = 2.47 acres
 1 sq. kilometer = 100 sq. hectometers = .386 sq. mile

Cubic Measure

1 cu. centimeter = 1000 cu. millimeters = .06 cu. inch
 1 cu. decimeter = 1000 cu. centimeters = 61.02 cu. inches
 1 cu. meter = 1000 cu. decimeters = 35.31 cu. feet

Approximate Conversion Factors

To change	To	Multiply by	To change	To	Multiply by
inches	centimeters	2.540	ounce-inches	newton-meters	.007062
feet	meters	.305	centimeters	inches	.394
yards	meters	.914	meters	feet	3.280
miles	kilometers	1.609	meters	yards	1.094
square inches	square centimeters	6.451	kilometers	miles	.621
square feet	square meters	.093	square centimeters	square inches	.155
square yards	square meters	.836	square meters	square feet	10.764
square miles	square kilometers	2.590	square meters	square yards	1.196
acres	square hectometers	.405	square kilometers	square miles	.386
cubic feet	cubic meters	.028	square hectometers	acres	2.471
cubic yards	cubic meters	.765	cubic meters	cubic feet	35.315
fluid ounces	milliliters	29.573	cubic meters	cubic yards	1.308
pints	liters	.473	milliliters	fluid ounces	.034
quarts	liters	.946	liters	pints	2.113
gallons	liters	3.785	liters	quarts	1.057
ounces	grams	28.349	liters	gallons	.264
pounds	kilograms	.454	grams	ounces	.035
short tons	metric tons	.907	kilograms	pounds	2.205
pound-feet	newton-meters	1.356	metric tons	short tons	1.102
pound-inches	newton-meters	.11296			

Temperature (Exact)

°F	Fahrenheit temperature	5/9 (after subtracting 32)	Celsius temperature	°C
----	------------------------	----------------------------	---------------------	----

RECOMMENDED CHANGES TO EQUIPMENT TECHNICAL PUBLICATIONS



THEN...JOT DOWN THE
DOPE ABOUT IT ON THIS FORM.
CAREFULLY TEAR IT OUT, FOLD IT
AND DROP IT IN THE MAIL.

SOMETHING WRONG WITH PUBLICATION

FROM: (PRINT YOUR UNIT'S COMPLETE ADDRESS)

DATE SENT

PUBLICATION NUMBER

PUBLICATION DATE

PUBLICATION TITLE

BE EXACT PIN-POINT WHERE IT IS

PAGE
NO.

PARA-
GRAPH

FIGURE
NO.

TABLE
NO.

IN THIS SPACE, TELL WHAT IS WRONG
AND WHAT SHOULD BE DONE ABOUT IT.

TEAR ALONG PERFORATED LINE

PRINTED NAME, GRADE OR TITLE AND TELEPHONE NUMBER

SIGN HERE

